

Annex 1

Analysis of the market for wholesale local access provided at a fixed location (Market 3a) and the market for wholesale central access provided at a fixed location (Market 3b)

Case 1505331

1 November 2018

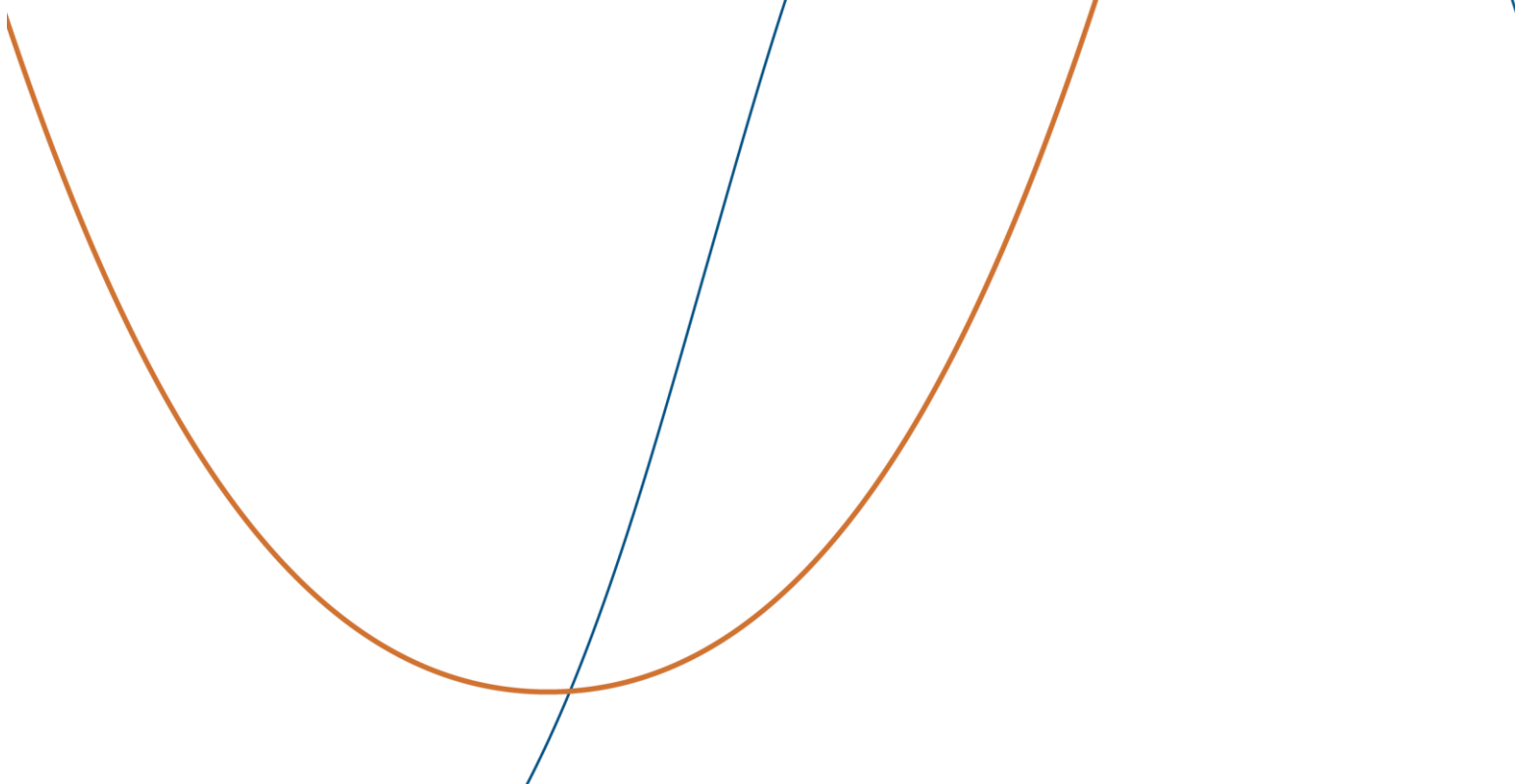

Summary

This document contains market analyses that the Norwegian Communications Authority (Nkom) has carried out on the market for wholesale local access provided at a fixed location (Market 3a) and the market for wholesale central access provided at a fixed location (Market 3b).

Market 3a is based on the market for wholesale (physical) network infrastructure access (including shared or fully unbundled access) at a fixed location (former Market 4), but is now being expanded to also include non-physical, virtual wholesale products whose functionality, from the wholesale customer's standpoint, is equivalent to today's LLU products.

Market 3b is based on the wholesale market for Broadband Access (former Market 5) and includes access products with regional or national connection that are used to provide broadband services in the mass market.

Since Market 3a and Market 3b are both derived from the same retail market, Nkom finds it appropriate to coordinate the market analyses for these two markets in a single document. The market analyses contain an assessment of whether there are providers with significant market power and will provide the basis for application of sector-specific measures.

Chapter 1 contains a description of the background and legal framework for the analysis.

Chapter 2 contains Nkom's definitions of the relevant markets. The chapter starts with a comprehensive description of the market and competition situation in the overall retail market for fixed access in Norway. The description includes fixed access to both households and businesses, and contains information on broadband coverage and the number of broadband customers, developments in customers broken down according to different technologies, developments in broadband customers' choice of products and capacities, the different customer segments in the retail market, and the providers' market shares.

Furthermore, Nkom defines and delimits the retail market for standardised broadband access. The market is technology neutral and includes all the technologies for access provided at a fixed location, i.e. copper, fibre, HFC and fixed radio access networks. Using the retail market for standardised broadband access as the starting point, Nkom then derives the relevant product markets at the wholesale level.

Market 3a comprises access to physical wholesale products in the copper and fibre networks and corresponding or comparable virtual wholesale products in the copper and fibre networks that have the following characteristics: 1) local access, 2) service independent, uncontended connection, and 3) access buyer has control over the connection. Market 3b comprises wholesale access at regional or central levels, and wholesale access offered at local level, but does not fulfil the other requirements for products in Market 3a, via copper networks, fibre networks, HFC networks and fixed radio access networks. Both markets include all internal and external sales of wholesale products within the relevant fixed broadband technologies.

In addition, Nkom has carried out a geographical analysis of developments in competition in the retail market. The analysis includes a review of geographical differences in the different providers' networks and coverage, the number of providers in the retail market and their market shares in various geographical areas, and geographical differences in prices and product offerings. The review shows that there are no clear differences in the competitive conditions in the retail market in stable, clearly delimited parts of the country that indicate that a geographical subdivision of the associated wholesale markets is necessary. Nkom therefore regards Markets 3a and 3b as national markets.

In Chapter 3, Nkom considers whether any of the providers have significant market power in Market 3a and/or Market 3b.

At the end of 2017, Telenor had a market share of 53.5 % in Market 3a. Telenor's relative size compared with its competitors gives the company competitive advantages that are relevant in both the retail market and the wholesale market. Furthermore, Telenor does not experience significant price pressure at the wholesale level, and there is no evidence that Telenor will be disciplined to an appreciable degree in the wholesale market given the absence of regulation. Telenor also controls a nationwide copper access network that is not easily duplicated. It would require significant investments for prospective providers to establish a fixed network that provides the basis for wholesale provision on par with Telenor's.

Moreover, Telenor is vertically integrated and offers broadband products in both the retail and the wholesale markets. Its position as the largest provider at both the wholesale and the retail level means Telenor has the possibility to achieve advantages from being vertically integrated. Telenor is also horizontally integrated and has a strong position in a number of adjacent markets within electronic communications, including fixed telephony, mobile telephony and TV services. Telenor's nationwide infrastructure and large customer base, at both the retail and the wholesale level, mean the company has significant economies of scale and scope. Telenor also has the opportunity to differentiate its products to a greater extent than its competitors by bundling retail products and services from multiple markets.

Following an overall assessment of Telenor's competitive position, Nkom concludes that the company can behave independently of its competitors, customers and consumers to an appreciable extent and that Telenor thus has significant market power in Market 3a.

In Market 3b Telenor had a market share of 42.6 % at the end of 2017. Several of the findings from the analysis in Market 3a also apply to Telenor in Market 3b, including Telenor's relative size compared with its competitors, control of a nationwide copper access network that is not easily duplicated, vertical and horizontal integration, economies of scale and scope, and greater ability to differentiate its products than its competitors by bundling retail products and services from multiple markets.

Following an overall assessment of Telenor's competitive position, Nkom again concludes that the company can behave independently of its competitors, customers and consumers to an appreciable extent and that Telenor has significant market power in Market 3b.

Contents

1	Introduction.....	8
1.1	Background and framework for the analysis	8
1.2	Previous analysis of the wholesale markets for LLU and Broadband Access, plus the market for wholesale terminating segments of leased lines	11
2	Definition of the relevant market.....	12
2.1	Market definition in general	12
2.1.1	The product market.....	12
2.1.2	The geographical market.....	13
2.2	The market and competitive situation in the retail market for fixed access	14
2.2.1	Coverage and number of customers in the retail market for fixed broadband access....	14
2.2.2	Customer developments broken down by different access technologies in the retail market for fixed access.....	16
2.2.3	Developments in broadband customers' choice of access products and speeds.....	18
2.2.4	Different customer segments in the retail market for fixed access	21
2.2.5	The providers' market shares in the retail market for fixed access	23
2.2.6	Development trends in the retail market for fixed access	31
2.3	Definition of the product market for standardised broadband access at the retail level	33
2.3.1	Delimitation between standardised broadband access and high-quality access products in the retail market.....	34
2.3.2	Definition of the retail market for standardised broadband access	35
2.3.3	Delimitation against mobile broadband and fixed radio access in the retail market for broadband at a fixed location	40
2.4	Delimitation of the derived product markets at the wholesale level	43
2.4.1	Different types of wholesale services	44
2.4.2	Assessment of the distinction between the market for wholesale local access and the market for wholesale central access.....	46
2.4.3	Assessment of Market 3a Wholesale Local Access criteria for each technology platform	49
2.4.4	Assessment of Market 3b Wholesale Central Access criteria for each technology platform	58
2.4.5	Assessment of the need for delimitation of sub-markets within Markets 3a and 3b based on capacity or technology	65
2.4.6	Delimitation of the markets for wholesale central and local access against the wholesale market for high-quality access products.....	69
2.4.7	Delimitation of the markets for wholesale central and local access against individual fibre accesses outside systematically developed access networks.....	71
2.5	Definition of the relevant geographical markets	73

2.5.1	General	73
2.5.2	Developments in competition in the Norwegian retail market for standardised broadband access.....	74
2.5.3	Geographical differences in providers' networks and coverage.....	79
2.5.4	Number of providers in the retail market, and their market shares, at the municipal level	85
2.5.5	Geographical differences in prices and product offerings	86
2.5.6	Summary and conclusion of the assessment of geographical markets for broadband access	97
2.6	Conclusion concerning market definition	99
3	Analysis of Market 3a and Market 3b	100
3.1	Framework for assessment of significant market power.....	100
3.2	General – significant market power	102
3.3	Market shares.....	103
3.3.1	Market shares as an indicator of significant market power in general.....	103
3.3.2	Market 3a	105
3.3.3	Market 3b	113
3.4	The size of the companies	120
3.4.1	Market 3a and Market 3b	121
3.5	Price developments.....	122
3.5.1	Market 3a	122
3.5.2	Market 3b.....	123
3.6	Complaints, appeals and supervisory matters	125
3.6.1	SHDSL.bis	125
3.6.2	Telenor's VULA product for fibre	125
3.6.3	Location data in connection with subloop unbundling.....	125
3.6.4	Notification of changes in connection with upgrade of the copper network.....	126
3.6.5	Non-disclosure and confidentiality requirements in electronic communications networks	127
3.6.6	Telenor's prices for fibre-based Broadband Access	128
3.6.7	Other miscellaneous appeals	128
3.6.8	Overall assessment of the complaints and conflicts in the regulatory period – Market 3a and Market 3b	129
3.7	Control of infrastructure that is not easily duplicated.....	130
3.7.1	Market 3a	130
3.7.2	Market 3b	131
3.8	Sunk costs.....	132
3.8.1	Market 3a	132
3.8.2	Market 3b.....	133
3.9	Vertical and horizontal integration	134

3.9.1	Market 3a and Market 3b	134
3.10	Economies of scale and scope	135
3.10.1	Market 3a	135
3.10.2	Market 3b	136
3.11	Product differentiation.....	137
3.11.1	Market 3a and Market 3b	137
3.12	Access to financial resources.....	138
3.12.1	Market 3a and Market 3b	139
3.13	Access to distribution and sales channels	139
3.13.1	Market 3a and Market 3b	140
3.14	Regulatory measures that may facilitate market entry	140
3.14.1	The Broadband Development Act	140
3.14.2	Regulations on cable above, below and alongside public roads.....	141
3.14.3	The state aid scheme to roll out broadband infrastructure.....	142
3.14.4	Overall assessment of the suitability of the regulatory measures to facilitate market entry	142
3.15	Potential competition.....	143
3.15.1	Market 3a and 3b	143
3.16	Countervailing buying power	145
3.16.1	Market 3a and Market 3b	146
3.17	Competition pressure from the retail market.....	147
3.17.1	Market 3a and 3b	148
3.18	Summary and conclusions.....	149
3.18.1	Market 3a	149
3.18.2	Market 3b	151

1 Introduction

1.1 Background and framework for the analysis

1. The regulatory framework for electronic communications is based on five directives adopted by the European Union (EU)¹. These directives have been implemented in Norwegian law by Act no. 83 of 4 July 2003 concerning electronic communications (Electronic Communications Act) and the appurtenant regulations, including Regulation no. 401 of 16 February 2004 on electronic communications networks and services (Electronic Communications Regulation)

2. The framework shall lay the foundation for the harmonisation of regulation in the European Economic Area (EEA), limit entry barriers, and facilitate sustainable competition to the benefit of the users.

3. It follows from Sections 3-2 and 3-3 of the Electronic Communications Act, and Norway's obligations under the EEA Agreement, that identification of providers with significant market power must take place in accordance with the guidelines and recommendations prepared by the EFTA Surveillance Authority (ESA) under the new framework directive for electronic communications services:

- Guidelines on market analysis and the assessment of significant market power (hereinafter referred to as the Guidelines)²
- Recommendation on relevant markets (hereinafter referred to as the Recommendation³)

4. According to the Guidelines, an assessment of relevant markets and significant market power must be based on a market analysis. The assessment must be in accordance with competition law methodology. The Guidelines and the Recommendation, together with relevant provisions in the Electronic Communications Act, particularly Sections 3-1 to 3-3, will therefore form the legal framework for the market analysis.

5. ESA revised the original Recommendation⁴ concerning relevant markets for the first time in 2008. The number of pre-defined markets for ex-ante regulation was then reduced from

¹ Directive 2002/21/EC on a common regulatory framework for electronic communications networks and services (Framework Directive); Directive 2002/20/EC on the authorisation of electronic communications networks and services (Authorisation Directive); Directive 2002/19/EC on access to, and interconnection of, electronic communications networks and associated facilities (Access Directive); Directive 2002/22/EC on universal service and users' rights relating to electronic communications networks and services (Universal Service Directive); Directive 2002/58/EC concerning the processing of personal data and the protection of privacy in the electronic communications sector (Directive on privacy and electronic communications).

² EFTA Surveillance Authority Guidelines of 14 July 2004.

³ EFTA Surveillance Authority Recommendation of 11 May 2016 with the Commission's Explanatory Note.

⁴ The EFTA Surveillance Authority Recommendation of 14 July 2004 was identical to the Commission's Recommendation of 11 February 2003.

18 to 7. The European Commission (hereinafter referred to as “the Commission”) revised the list of relevant markets again and adopted a new recommendation on 9 October 2014⁵. The number of pre-defined markets for ex-ante regulation was then reduced to 5. The new recommendation was published with an Explanatory Note⁶, explaining in more detail the background of the revised list of relevant markets. ESA published an identical recommendation for the EEA/EFTA states on 11 May 2016⁷.

6. The 2016 Recommendation includes changes in the market definition for the wholesale markets for fixed access compared with the 2008 Recommendation, which was used as the basis for Nkom’s current decision in the wholesale markets for broadband access based on fixed networks and leased lines. In the Recommendation from 2016, the former Markets 4, 5 and 6 are replaced with the following relevant markets:

- Market 3a: *Wholesale Local Access at a fixed location*
- Market 3b: *Wholesale Central Access at a fixed location (to provide mass-market services)*
- Market 4: *Wholesale high-quality access*

7. The wholesale market for local access provided at a fixed location (hereinafter “Market 3a”) is based on former Market 4, but is now being expanded to also include non-physical, virtual wholesale products whose functionality, from the wholesale customer’s standpoint, is equivalent to today’s LLU products.

8. The market for wholesale central access provided at a fixed location (hereinafter “Market 3b”) is based on former Market 5 and includes access products with regional or national connection points that are used to provide broadband services in the mass market.

9. The wholesale market for high-quality access to fixed access networks (hereinafter “Market 4”) is based on former Market 6, but is now focused on wholesale products that allow buyers of access to offer services to businesses that need greater functionality and/or quality than is provided by the standard access products in the mass market.

10. With regard to former Market 6, Nkom used a slightly different delimitation of the relevant market than the market definition in the ESA Recommendation. The former wholesale markets for leased lines (former Markets 13 and 14) were defined as leased lines with capacities up to and including 8 Mbit/s and over 8 Mbit/s, respectively. In other words, Nkom did not distinguish explicitly between terminating and trunk segments of leased lines in the same way as the Recommendation. Nkom held that speed was the criterion that best reflected

⁵ Commission Recommendation of 9 October 2014.

⁶ <https://ec.europa.eu/digital-single-market/en/news/explanatory-note-accompanying-commission-recommendation-relevant-product-and-service-markets>

⁷ The ESA Recommendation does not have a separate Explanatory Note, but refers to the Commission’s Explanatory note.

the distinction between terminating and trunk segments in the Norwegian market, and that this delimitation was not contrary to the delimitation in the Recommendation.

11. Former Market 13 was continued as Market 6, while former Market 14 was removed from ESA's recommended relevant markets in 2008. In 2012, Nkom conducted a new analysis of Market 6 and concluded that speed was still the criterion that best reflected the distinction between terminating and trunk segments in the Norwegian market. Nkom thus continued to use the delimitation of the access market to apply to leased lines with capacities up to and including 8 Mbit/s. At the same time, Nkom removed its regulation of former Market 14. The market for wholesale high-quality access provided at a fixed location (Market 4) will therefore be able to include all the products in former Market 6, plus high-quality access products over 8 Mbit/s that were not included in former Market 6.

12. In the document "Methodology for market analysis" (the Methodology Document) Nkom has elaborated on the criteria for the market analysis in certain respects. The Methodology Document is not legally binding, but expresses Nkom's understanding of the guidelines that Nkom is obliged to follow. The market analyses will therefore be undertaken in accordance with the views and assessments expressed in the Methodology Document. In the event of any inconsistencies between the Methodology Document and the Guidelines or the Recommendation, the Guidelines or the Recommendation will take precedence. The document in no sense regulates the Norwegian Competition Authority's assessments in accordance with the Norwegian Competition Act. This analysis is based on the Methodology Document dated 11 June 2009.

13. The work on the market analysis can be naturally divided into three stages:

- 1) Define relevant markets by defining relevant product markets and geographical markets.
- 2) Carry out market analyses of each of the relevant markets with a view to uncovering whether any providers have significant market power.
- 3) Impose obligations on providers designated as having significant market power.

14. This analysis includes Nkom's assessments in phases 1) and 2) for the markets for wholesale local and central access provided at a fixed location (Market 3a and Market 3b, respectively). The market for wholesale high-quality access provided at a fixed location (Market 4) will be analysed separately. The description of the market and competition situation in the retail market for fixed access (Section 2.2 below) is identical in the analyses of Markets 3a & 3b and Market 4.

15. The market analysis is an annex to the draft decision in which Nkom gives notice that it wishes to impose specific obligations on a provider considered to have significant market power. Pursuant to Section 3-4 of the Electronic Communications Act and Norway's

obligations under the EEA Agreement, Nkom is obliged to impose at least one specific obligation on providers with significant market power.

16. Market shares and other statistics in the analysis are based on Nkom's electronic communications statistics for 2017, unless otherwise specified.

17. The market analyses will be subject to regular review. In markets with frequent and comprehensive changes, such reviews will have to be carried out relatively frequently. The market analyses are therefore limited in terms of how far into the future they apply, cf. paragraph 20 of the Guidelines. This analysis has a time horizon of two to three years.

1.2 Previous analysis of the wholesale markets for LLU and Broadband Access, plus the market for wholesale terminating segments of leased lines

18. The wholesale markets for local loop unbundling (LLU) and Broadband Access were established around the turn of the millennium. Broadband Access at the wholesale level in the form of bitstream access was introduced in connection with Report no. 24 (1998-99) to the Storting "Regarding certain regulatory issues in the telecom sector", when Telenor proposed it as an alternative to LLU. LLU was established as a product in the wholesale markets at a later date, as a result of the LLU Regulation that the EU adopted on 18 December 2000. The LLU Regulation was implemented in Norwegian law through amendments of the Public Telecommunications Networks and Services Regulations of 6 February 2001.

19. Nkom has previously issued three decisions regarding the regulation of the relevant markets. These decisions are dated 20 February 2006, 3 April 2009 and 20 January 2014.

20. Nkom's previous analysis of the broadband markets is dated 20 January 2014 and was based on the Recommendation from 2008. Nkom arrived at the following market definition for the wholesale markets for LLU (former Market 4) and Broadband Access (former Market 5):

- The LLU and Broadband Access markets constitute separate wholesale markets. Both markets are technologically neutral.
- Both the wholesale markets include all external and internal sales, or use, of broadband access products via all fixed access technologies that are used to offer broadband access in the retail market.
- The Broadband Access market covers all speeds offered by the wholesale provider's retail operations.
- Leased lines are not a substitute for LLU or Broadband Access, and are therefore not part of these relevant markets.

- The retail market for mobile network-based broadband access is not included in the same relevant market as fixed network-based broadband access. Wholesale provision of mobile network-based broadband access is thus not included in the LLU or Broadband Access market. However, fixed radio access (point-to-point and point-to-multipoint connections) are part of these relevant markets.
- Both the LLU market and the Broadband Access market are geographically limited to Norway.

21. Nkom's previous analysis of the market for terminating segments of leased lines (former Market 6) is dated 20 April 2012 and was based on the Recommendation from 2008. On the basis of assessments of the competitive situation and other specific national circumstances related to the Norwegian market for leased lines, Nkom has concluded that the relevant wholesale market for leased lines in Norway shall continue to be defined as leased lines with capacities up to and including 8 Mbit/s. The wholesale market for leased lines with capacities up to and including 8 Mbit/s was found to be national.

2 Definition of the relevant market

2.1 Market definition in general

22. Market analyses are based on the pre-defined markets in the ESA Recommendation on relevant markets. However, Nkom must assess whether ESA's pre-defined markets fit the circumstances in the Norwegian market.

23. The market definition should take into account the products included in the relevant markets as well as the geographical scope of the market. The definition of relevant markets must use the same procedure as the market definition within competition law. However, in some cases, markets defined by competition authorities may deviate from markets defined in the Recommendation or by national supervisory authorities in accordance with Article 15, no. 3 of the Framework Directive.

24. Nkom conducts market analyses in a forward-looking perspective based on the market and competition situation in Norway, cf. Section 2.2, using the predefined markets in the ESA Recommendation as its starting point.

2.1.1 The product market

25. In accordance with the Guidelines, Nkom has first delimited the relevant product markets at the retail level, in order then to derive the relevant product markets at the wholesale level.

26. A relevant product market is made up of products and services for which adequate substitutes can be found for the end user. The starting point for the definition of a relevant product market is an assessment of demand-side substitutability. However, substitutability may also exist on the supply side and may then be relevant in the delimitation of the relevant market.

27. Substitutability exists on the demand side when in the users' perception two or more products in the market are mutually interchangeable or substitutable on the basis of their characteristics, price and area of use. Supply-side substitutability exists when, in response to a marginal price change, providers of other (non-substitutable) products can change their production or distribution in the short term and offer substitutable products without incurring significant additional costs or risk.

28. An acknowledged method of analysing substitutability is the hypothetical monopolist test (SSNIP). The test seeks to identify the smallest market within which a hypothetical monopolist could exert market power. The starting point for the test is a marginal (in practice 5–10%), non-transitory increase in the price of the relevant product. The assessment is made on the basis of the assumed price level in a market with effective competition and assuming that all other prices are unchanged. The effect of the price increase in the relevant market and the overall effect on the producer's revenues are then assessed. Determining whether the price increase will be profitable for the producer is key.

29. The Guidelines do not make use of the SSNIP test an absolute requirement in the market definition. Similar methods may therefore also be used. Regardless of method, the hypothetical assessment should be supplemented by factual information about behaviour on the supply and demand sides to the extent that such information is available.

2.1.2 The geographical market

30. Once the relevant product markets have been defined, the geographical scope of the market is defined, cf. the Guidelines. The relevant geographical market may be defined as the area in which the relevant product is offered on approximately sufficiently similar or homogeneous competitive terms. Geographical markets within electronic communications have traditionally been defined based on the extent of the network and the jurisdiction of the legal regulation of the market.

31. The Norwegian Electronic Communications Act applies presumptively to Norwegian land territory. According to Section 1-3, first paragraph, of the Electronic Communications Act, the Act also applies to "Norwegian ships and aircraft and to installations and devices of whatever nature connected to petroleum activity on the continental shelf or for utilisation of renewable energy resources at sea within the scope of the Norwegian Offshore Energy Act". Electronic communications on Norwegian ships and aircraft and installations for utilisation of renewable energy resources at sea are regarded as of very little significance for the market analyses Nkom conducts pursuant to the Electronic Communications Act.

32. However, electronic communications on installations and devices connected to petroleum activity on the continental shelf are assumed to be of some significance to the market analyses Nkom conducts pursuant to the Electronic Communications Act. See the more detailed description in Section 2.2.5.

33. In addition, the Electronic Communications Act also applies to Svalbard, Jan Mayen, the dependencies and Antarctica. This follows from Regulation no. 882 of 4 July 2003 on the geographical scope of the Electronic Communications Act with regard to Svalbard, Jan Mayen, the dependencies and Antarctica, laid down pursuant to Section 1-3 of the Electronic Communications Act. In respect of Svalbard, exemptions have been made for Chapter 3 (significant market power), Chapter 4 (access) and Section 9-3 (consultation procedure) of the Electronic Communications Act. Electronic communications on Jan Mayen, the dependencies and Antarctica are assumed to have very little significance for the market analyses Nkom carries out pursuant to the Electronic Communications Act.

2.2 The market and competitive situation in the retail market for fixed access

34. This section provides a comprehensive description of the market and competition situation in the overall retail market for fixed access in Norway. The description includes fixed access to both households and businesses, and it contains information on broadband coverage and the number of broadband customers, customer developments broken down according to different technologies, developments in broadband customers' choice of products and capacities, the different customer segments in this retail market, and the providers' market shares.

35. The description of the overall retail market for fixed access forms the basis for the delimitation of the relevant product markets at the retail level and forms the basis for further delimitation and analysis of the related wholesale markets.

2.2.1 Coverage and number of customers in the retail market for fixed broadband access

36. According to Nkom's Coverage Report 2018, close to 100% of Norwegian households have broadband coverage with a downstream capacity of 4 Mbit/s or more. Of these, about 96% are covered by fixed, cable-based access technologies based on copper, fibre and/or HFC networks (hybrid fibre coaxial, also referred to as cable television networks)⁸.

37. More than 2 million households had chosen to purchase fixed broadband access at the end of 2017, which constitutes 85.3 % of Norwegian households. The number of residential broadband subscriptions has gradually increased in recent years. From the end of 2016 to the

⁸ "Broadband coverage 2018" from September 2018, prepared by Analysys Mason on assignment from Nkom.

end of 2017, the number of subscriptions increased by 52,000, while the corresponding growth from the end of 2015 to the end of 2016 was 59,000 subscriptions.

38. In addition, at the end of 2017 there were almost 130,000 subscriptions for fixed broadband access in the business market, a decrease of roughly 2,500 subscriptions from the end of 2016. In recent years there have been only minor changes in the number of fixed broadband subscriptions in the business market.

39. However, the business market for fixed access is more complex than the residential market and in addition to fixed broadband subscriptions also includes other access solutions. Companies' purchase of standardised broadband access, equivalent to broadband subscriptions in the residential market, has been categorised as fixed broadband access in Nkom's annual electronic communications statistics. If companies purchase other fixed access solutions with additional features or functionality beyond standardised broadband access, such as IP-VPN services, this is categorised as data communication services in Nkom's electronic communications statistics. At the end of 2017, the electronic communications providers reported approximately 72,000 subscriptions at the retail level for data communications services. There have been no major changes in this figure in recent years. These data communication services usually also include access to the internet. In this context, it is therefore natural to regard these services, and the business customers that make use of these data communications services, as part of the retail market for fixed access.

40. The same is true for companies that buy different capacity products from electronic communications providers for use in the companies' access solutions. In Nkom's annual electronic communications statistics, these kinds of products are included in the product category leased lines. However, it has proven difficult for providers of leased lines to report a distinction between products that the customers use for terminating and trunk purposes respectively. Consequently, Nkom does not distinguish between terminating and trunk segments of leased lines in the annual electronic communications statistics. At the end of 2017, total sales of leased lines in the retail market amounted to 15,000 lines. The proportion of these lines that are included in the access solutions of companies that purchase leased lines is included in the retail market for fixed access. However, the available information from the electronic communications providers does not provide grounds for further quantification of this proportion.

41. This means that the available information from the electronic communications providers about data communication services and terminating segments of leased lines does not allow quantification of the portion of the retail market for fixed access for these products as unambiguously as the part of the market that includes standard fixed broadband access in the residential and business markets.

2.2.2 Customer developments broken down by different access technologies in the retail market for fixed access

42. Figure 1 shows the development in the number of fixed broadband subscriptions in the residential market, broken down by access technology, for the period 2006 to 2017.

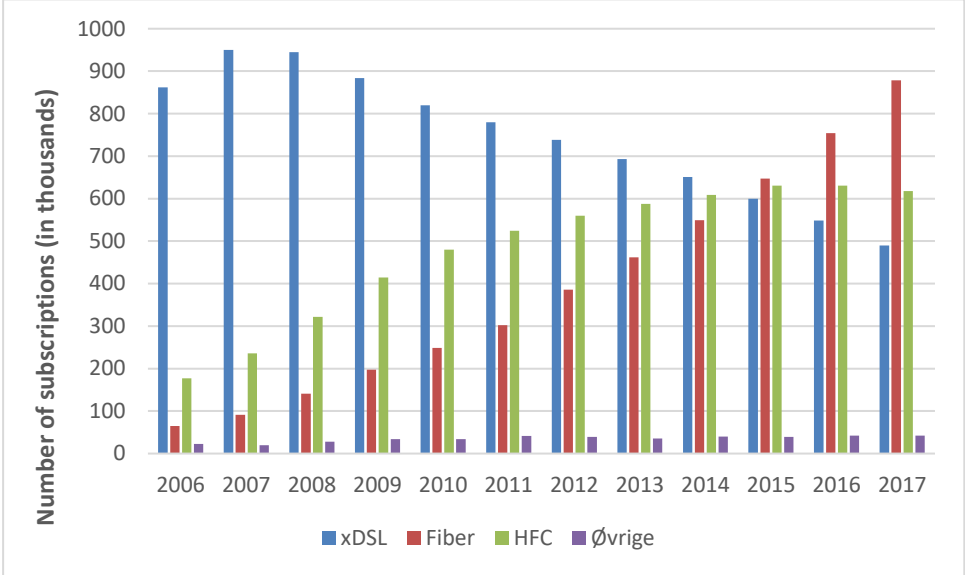

Figure 1: Fixed broadband subscriptions aimed at the residential market, broken down by access technology. (Source: Nkom’s electronic communications statistics for 2017)

43. There were 490,000 residential broadband subscriptions based on xDSL at the end of 2017, a decrease of roughly 59,000 compared with year-end 2016. Together xDSL constituted 24.2% of the total number of subscriptions in the residential market, compared just over 27.8% at the end of 2016. Broadband based on VDSL amounted to 33.9% of the xDSL subscriptions at the end of 2017, an increase from 29.9% from the end of 2016.

44. Broadband access based on xDSL is no longer the largest access technology in the residential market. Broadband access via fibre has grown most in recent years and has been the most widely used access technology in residential broadband subscriptions since 2015. At the end of 2017 there were 878,000 fibre-based subscriptions in the residential market, an increase of just over 124,000 subscriptions from the end of 2016. Over 43% of the residential broadband subscriptions were based on fibre, up from 38% at the end of 2016.

45. Broadband access via HFC network was the second largest form of access in the residential market with more than 617,000 subscriptions at the end of 2017. This is a decrease of more than 13,000 subscriptions compared with the end of 2016. There has been an increase in the number of broadband subscriptions via HFC network for many years, but from 2010 the growth has been diminishing, and 2017 saw a substantial decline in the number of accesses. Broadband via HFC network constituted approximately 30% of the total number of subscriptions in the residential market at the end of 2017.

46. Figure 2 shows the development in the number of fixed broadband subscriptions in the business market, broken down by access technology, for the period 2006 to 2017.

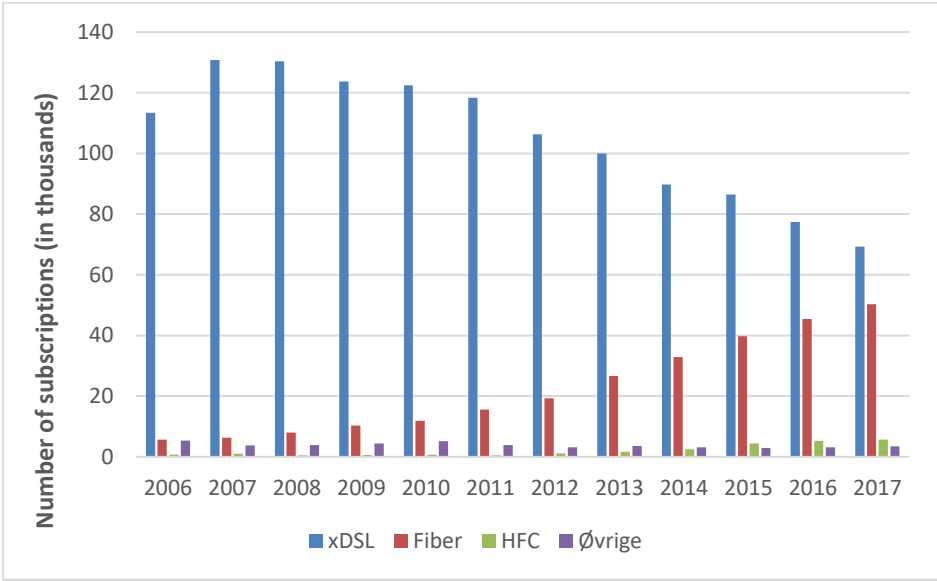

Figure 2: Fixed broadband subscriptions aimed at the business market, broken down by access technology. (Source: Nkom’s electronic communications statistics for 2017)

47. There were approximately 69,000 broadband subscriptions based on xDSL in the business market at the end of 2017, a decrease of roughly 8,000 subscriptions compared with the end of 2016. xDSL-based broadband subscriptions accounted for approximately 54% of the total number of fixed broadband subscriptions in the business market at the end of 2017, compared with just under 59% at the end of 2016.

48. In the business market too, broadband access via fibre is the connection form that has had the greatest growth in recent years. At the end of 2017 there were more than 50,000 fibre-based subscriptions in the business market, an increase of almost 4,900 subscriptions compared with the end of 2016. This means that 39% of the business subscriptions were based on fibre at year-end 2017, up from around 35% at the end of 2016.

49. Figure 3 shows that the number of subscriptions for fixed broadband access in the combined residential and business market amounted to over 2,156,000 at the end of 2017. These subscriptions were distributed as follows: approximately 26% via xDSL, 43% via fibre access, 29% via HFC network and 2% via fixed radio access.

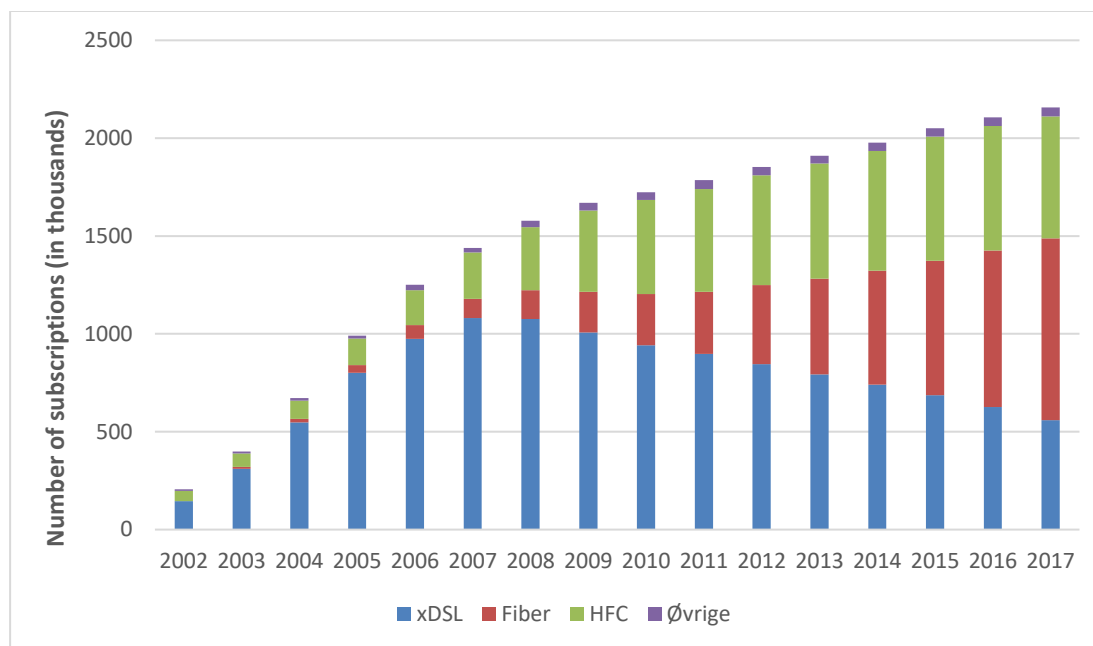

Figure 3: Fixed broadband subscriptions aimed at the residential and business market, broken down by access technology. (Source: Nkom's electronic communications statistics for 2017)

50. As previously mentioned, portions of the business market cover their needs for fixed access by requesting access products or solutions such as IP VPN and leased lines, instead of a fixed broadband subscription. These kinds of access solutions are realised through a mix of copper and fibre accesses, depending on the capacity needs of the individual company location and the access options available. There is no available information from providers of IP VPN solutions and leased lines for access that allows quantification of the relative developments in copper and fibre accesses included in these kinds of access products and solutions. However, there are grounds to assume that there has been a gradual migration from copper to fibre accesses also in this part of the market in recent years, in the same way as in both the residential market and the business market for fixed broadband subscriptions.

2.2.3 Developments in broadband customers' choice of access products and speeds

51. A variety of products are offered in the retail market for fixed broadband access. The different products have different subscription prices. The price differences reflect different downstream and upstream access speeds and different degrees of additional services. Several providers of fixed broadband access aimed at the residential market also offer product packages that in addition to Internet access also include VoIP, TV packages, video-on-demand services and various cloud services.

52. Figure 4 shows the capacities bought by broadband customers in Norway. At the end of 2017, 63.6% of broadband customers had a subscription with a marketed downstream speed of 30 Mbit/s or more. The number of subscriptions with a marketed downstream speed of 30 Mbit/s or more increased from over 1,200,000 subscriptions at the end of 2016 to over 1,320,000 subscriptions at the end of 2017. The number of subscriptions with a marketed

downstream speed of less than 10 Mbit/s decreased from 335,000 to 205,000 in the same period.

53. In terms of upstream speed, 615,000 broadband customers had a subscription with a marketed upstream speed of between 10 Mbit/s and 30 Mbit/s at the end of 2017, compared with 589,000 at the end of 2016. At the end of 2017, 13.8% of broadband customers had chosen to buy a subscription with a marketed upstream speed of 100 Mbit/s or more, while the corresponding figure at the end of 2016 was approximately 6.7%.

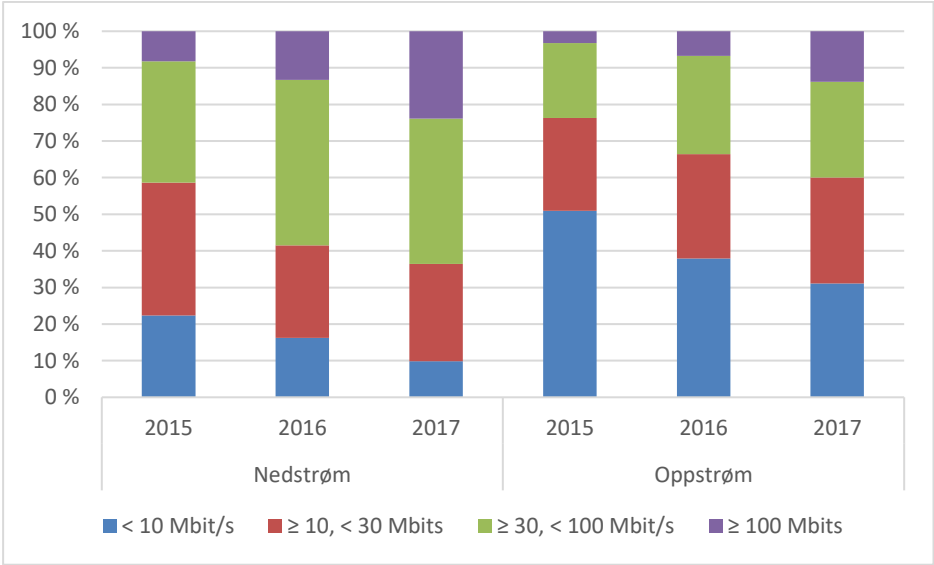

Figure 4: Fixed broadband subscriptions aimed at the combined residential and business market, broken down by speed. All access technologies. (Source: Nkom’s electronic communications statistics for 2017)

54. This shows that Norwegian broadband customers are buying fixed broadband access with ever higher speeds. The need for increased capacity has grown gradually over several years and is related to the fact that ever more broadband customers are using their broadband subscription for services that require more bandwidth. In the residential market, a major driver behind the increased demand for high-capacity broadband access is increased use of various OTT services, such as streaming of TV series, films and sporting events. Figure 5 shows that more of the fibre customers in the residential market buy access products with higher speeds than broadband customers with broadband access based on xDSL or HFC network, but it also shows that demand for higher capacities increased from 2015 to 2017 for all three access technologies.

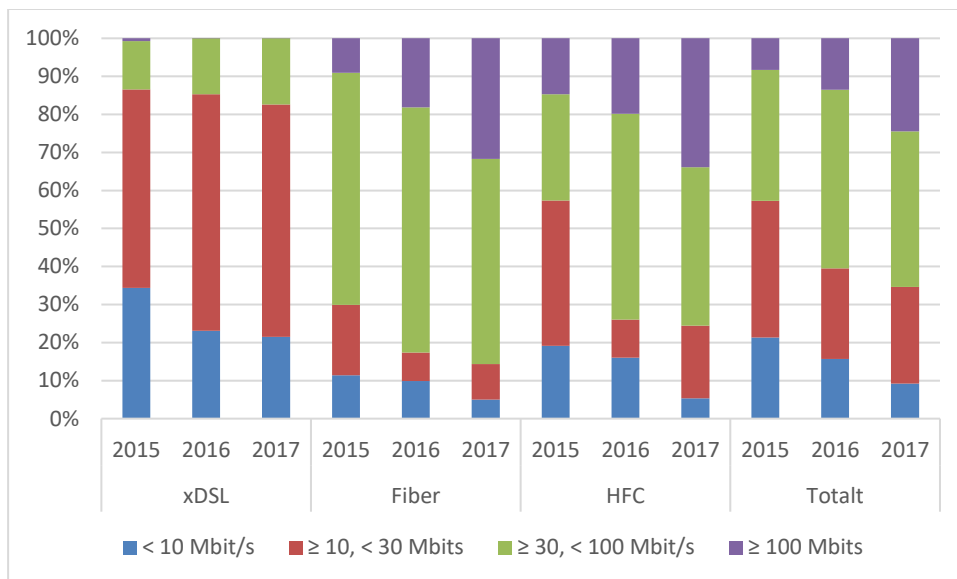

Figure 5: Subscriptions for fixed broadband access broken down by speed. Residential market. Downstream speed (Source: Nkom’s electronic communications statistics for 2017)

55. The same trend in terms of higher demand for increasingly higher capacities is also observed in the business market. Increased use of different forms of cloud services is a major reason for this. Figure 6 nevertheless shows that more households than companies choose to buy fixed broadband access with the highest speeds. For example, at the end of 2017 some 65.4% of the broadband customers in the residential market had purchased a broadband subscription with a marketed downstream speed of 30 Mbit/s or more, while the corresponding proportion in the business market was only just over 36.2%.

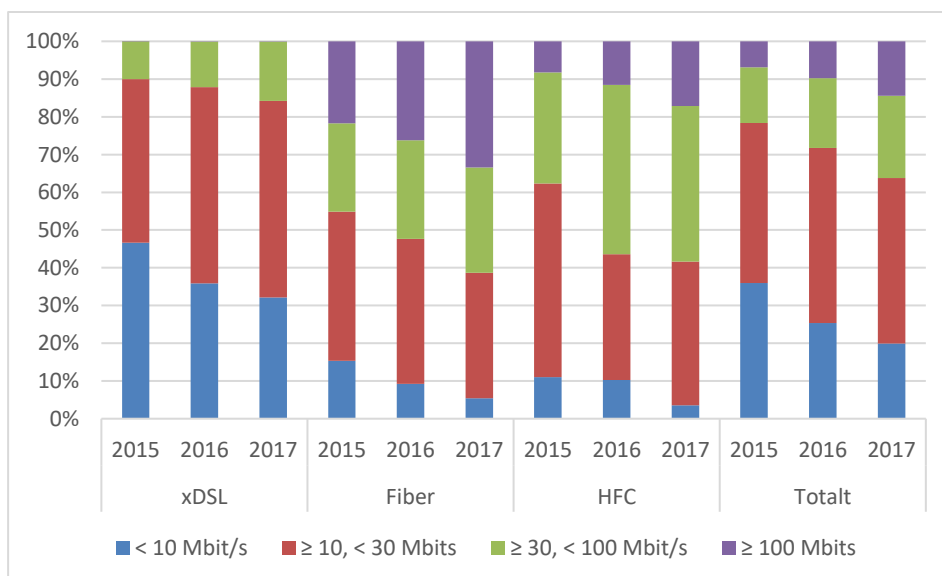

Figure 6: Subscriptions for fixed broadband access broken down by speed. Business market. Downstream speed (Source: Nkom’s electronic communications statistics for 2017)

56. This concurs with figures from Statistics Norway’s internet survey⁹, which indicate that the median speed of broadband subscriptions in the residential market increased from 32.5 Mbit/s in the second quarter of 2017 to 47.9 Mbit/s in the second quarter of 2018, while the median speed of broadband subscriptions in the business market increased from 15.9 Mbit/s to 19.1 Mbit/s in the same period. Figure 7 shows the change in median speed of broadband subscriptions in the residential and business markets respectively from the second quarter of 2009 to the second quarter of 2018.

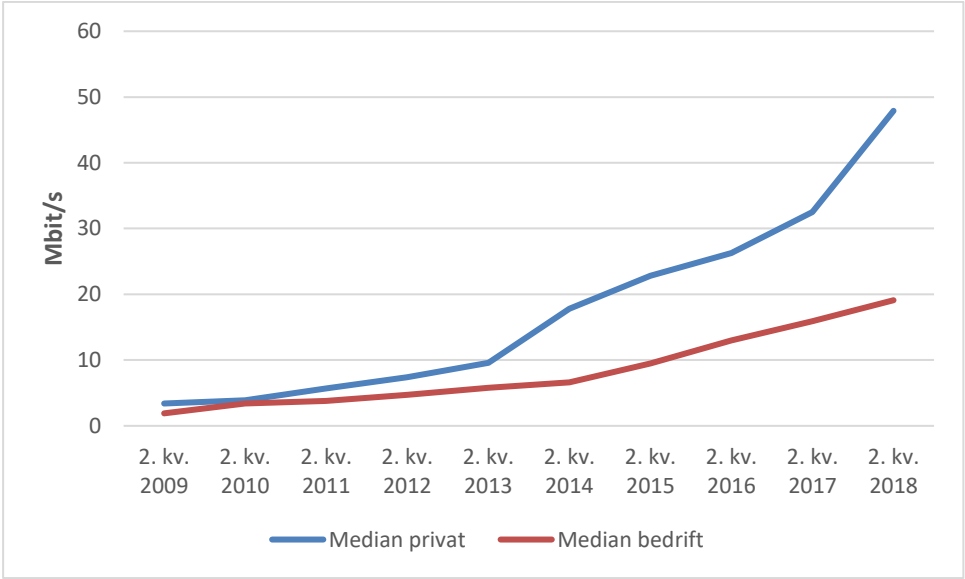

Figure 7: Capacity of broadband subscriptions. Median in the residential and business markets. Downstream speed (Source: Statistics Norway’s internet survey)

57. Although the median speed when purchasing standard broadband subscriptions is lower in the business market than in the residential market, the capacity need seems significantly more heterogeneous in the business market. For example, figure 6 demonstrates that over half of the companies with a broadband subscription via fibre purchase a broadband access with capacities above 30 Mbit/s. In addition, there is reason to assume that most of the companies that meet their access needs via products and solutions such as IP VPN and leased line access, and that are therefore not represented in either Nkom’s or Statistics Norway’s figures for speeds of standard broadband subscriptions, have capacity needs that are significantly greater than the average capacity needs of the companies that buy standard broadband subscriptions.

2.2.4 Different customer segments in the retail market for fixed access

58. Providers of fixed broadband access differentiate in their marketing between standard access products for the residential market and the business market. Providers operating in both the residential and the business market, however, generally offer the same broadband capacities to both households and companies. Where prices vary for provision of the same

⁹ Statistics Norway: Internet survey, second quarter 2018

capacity to households and businesses, this generally reflects differences in the product. For example, business subscriptions may differ slightly from residential subscriptions or contain additional features and services that it is not natural to include in a residential subscription.

59. Parts of the demand side of the retail market will nevertheless experience the difference between the fixed broadband access products marketed to the residential and business markets as relatively minor. These are standard products that are offered to both households and businesses, with corresponding standard price lists and standard terms. For many small businesses, and especially sole proprietorships with the same address as the self-employed person's home address, there seems to be a high degree of substitutability between fixed broadband access packages marketed to the residential market and the business market respectively. Although households and businesses comprise different customer segments for the suppliers in the retail market for fixed broadband access, several factors thus indicate that these two customer segments are in fact part of the same relevant product market at the retail level, cf. Section 2.3 below where the relevant product markets are defined.

60. With regard to business customers that require access solutions with quality and/or functionality beyond what is included in the above-mentioned standard broadband subscription, this customer segment differs from the rest of the demand side in the retail market for fixed access. These are often companies with multiple locations and/or units, or companies with high demands regarding quality, availability and/or service level. For these kinds of companies, it is not an option to purchase a standard broadband subscription. These are companies that fall into the category that the Commission calls the retail high-quality market on page 36 of the Explanatory Note (hereinafter referred to as "the high-quality market"). For example, these companies want IP VPN products, Ethernet VPN products, capacity products such as leased lines and wavelengths / optical channels or dark fibre to establish access solutions that meet more advanced communication needs than companies that want a standard broadband subscription have.

61. In addition to significant differences in needs on the demand side, the high-quality market differs from the standard broadband subscription market in that the individual company's requirements form the basis for the products and prices offered by the providers in the retail market. In the high-quality market, the purchase process usually includes some form of dialogue or negotiation between the company and the relevant providers, and the company's specified requirements form the basis for the concrete solution offered in the individual case. This entails a completely different purchase process than that in the market for standard broadband subscriptions.

62. On this basis, the distinction between standard broadband subscriptions and access products requested by companies with more advanced communication needs is the clearest distinction between customer segments in the retail market for fixed access. Although providers of standard broadband subscriptions also differentiate between offers to households and businesses, it is not as obvious that this distinction will lead to the standard broadband

subscriptions to the residential and business markets being defined as different relevant product markets, cf. Section 2.3 below on the definition and delimitation of product markets.

2.2.5 The providers' market shares in the retail market for fixed access

Standard fixed broadband access

63. Figure 8 shows that Telenor is by far the largest provider of fixed broadband access in the residential market, with a market share of 40.7% in 2017, measured by sales revenue. Telenor's market share gradually decreased in the period up until 2016, but has increased slightly in 2017. Get is the second largest provider with a market share of 14.5% in 2017, followed by Lyse Fiber¹⁰, NextGenTel, Eidsiva Bredbånd and NTE Marked with market shares of 11.3%, 6.1%, 2.6% and 2.4% respectively. It should be noted that the supply side in the residential market consists of a large number of small providers, including several local and regional operators, which together represent, just under a quarter of the fixed broadband accesses in the residential market.

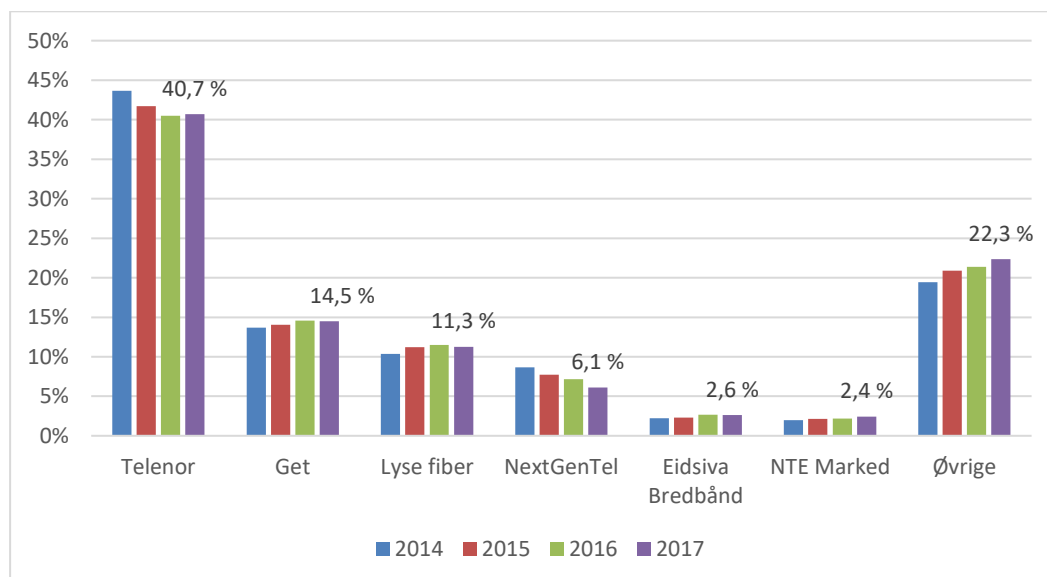

Figure 8: Market shares for fixed broadband aimed at the residential market, measured by sales revenue. (Source: Nkom's electronic communications statistics for 2017)

64. Figure 9 shows the market shares in the residential market, measured by number of subscriptions. A comparison of figures 8 and 9 shows that there are no major differences in relative market shares in the residential market based on sales revenue and number of subscriptions. The biggest difference is in Get's market share. It is assumed that this difference is largely due to the fact that Get has relatively more housing cooperative customers than most of the other providers. Given that the subscription rates for housing cooperatives other commonhold associations are on average slightly lower than for individual homes, this

¹⁰ Lyse Fiber's market shares include Viken Fiber, Signal Bredbånd, StayOn and Istad Fiber.

explains why Get’s market share is higher when measured by number of subscriptions than when measured by sales revenue.

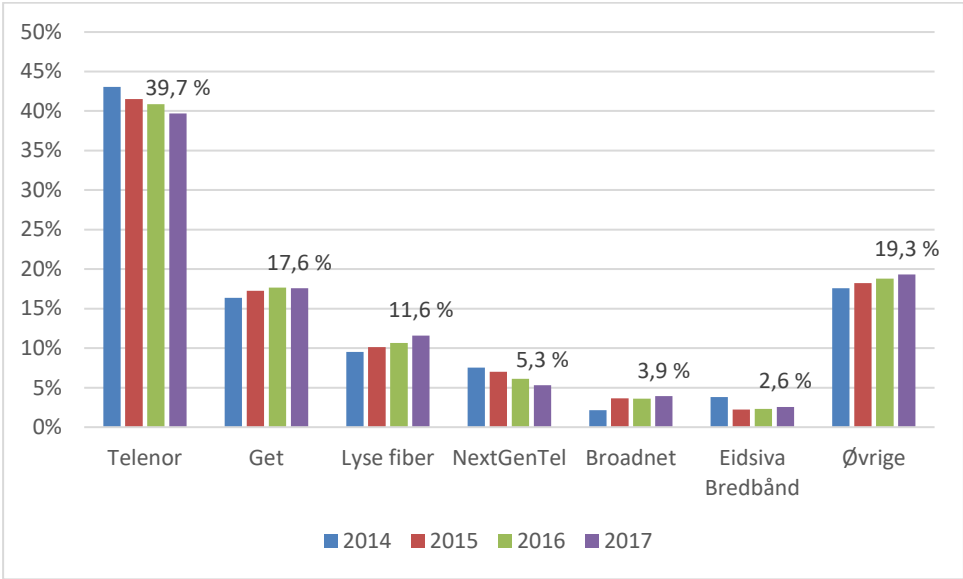

Figure 9: Market shares for fixed broadband aimed at the residential market, measured by number of subscriptions. (Source: Nkom’s electronic communications statistics for 2017)

65. Nkom collects information about the number of broadband subscriptions for businesses and related sales, but does not differentiate between high-quality and standardised broadband access in the electronic communications statistics. Nkom does not, therefore, have precise information about the number of subscriptions or sales revenue for standard broadband access in the business market. Nkom nevertheless assumes that a large proportion of the broadband subscriptions in the business market can be regarded as standard broadband access.

66. Figure 10 shows that in the business market too Telenor is the largest provider of fixed broadband access measured by sales revenue, with a market share of 28.1% in 2017. Broadnet¹¹ acquired DataGuard in October 2015 and Powertech in February 2016, giving it a market share of 20.3% in the business market, measured by sales revenue. Lyse Fiber’s and BKK Digitek’s market shares have increased slightly to 9.1% and 4.2% respectively, while NextGenTel’s market share has dropped to 3.9%. The other providers have a combined market share of 31.2%, measured by sales revenue.

¹¹ Broadnet’s market shares include Dataguard, Homenet, Powertec Information Systems, Lynet internett and Xfiber.

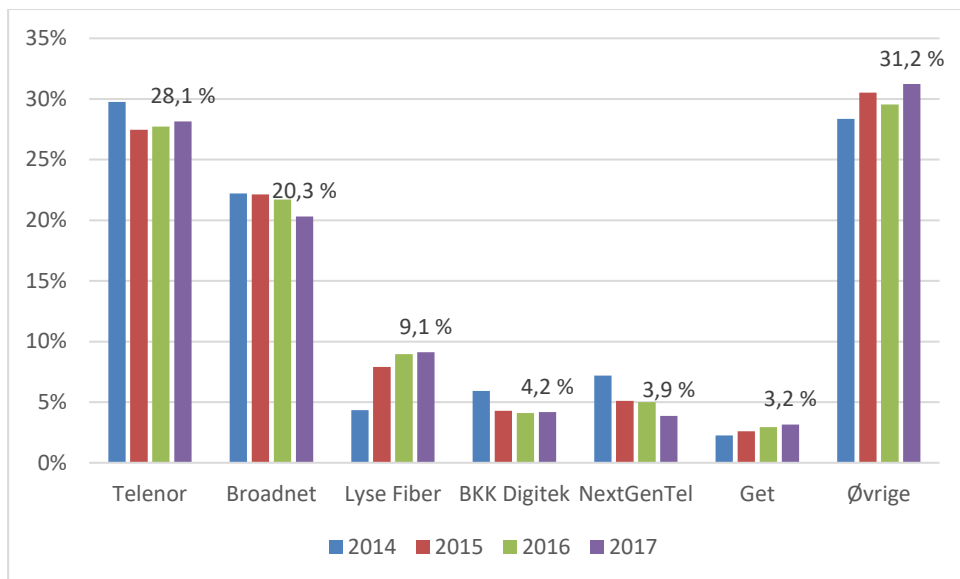

Figure 10: Market shares for fixed broadband aimed at the business market, measured by sales revenue. (Source: Nkom's electronic communications statistics for 2017)

67. Figure 11 shows the market shares in the business market for fixed broadband access, measured by number of subscriptions. A comparison of figure 10 and figure 11 shows that the market share distribution looks rather different if the market shares are calculated on the basis of number of subscriptions instead of sales revenue. In this case, Telenor's market share increases by approximately 13 percentage points to 41.4%, while the category "Other" decreases by some 8 percentage points. Also for the other providers, there are some major differences in market shares based on the two methods of measurement.

68. Nkom assumes that the main reason for the major differences in market share measured by sales revenue and measured by number of subscriptions is the significant heterogeneity in the business market. Major differences in the composition of access products and speeds with associated supplementary products that the various providers sell in this market explain the difference in market shares for several of the providers based on the two different measuring methods.

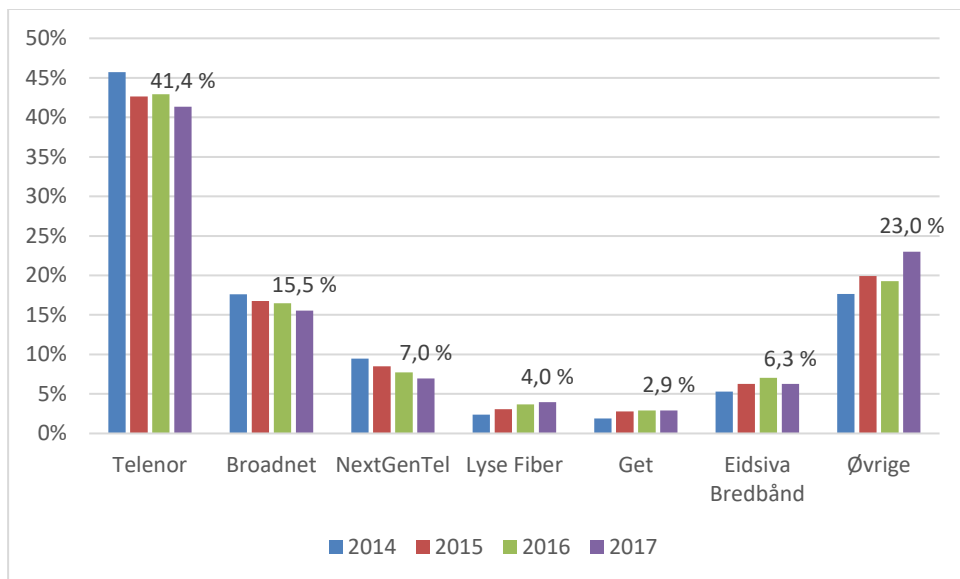

Figure 11: Market shares for fixed broadband aimed at the business market, measured by number of subscriptions. (Source: Nkom's electronic communications statistics for 2017)

69. Figure 12 shows that Telenor has a market share of 38.4% measured by sales revenue in the combined residential and business market for fixed broadband access. The second largest provider in the combined market for fixed broadband access is Get, with a market share of 12.4%. Four other providers have market shares of between 10.5% and 2.7% each, while the other providers of fixed broadband access together represent around 24% of this market.

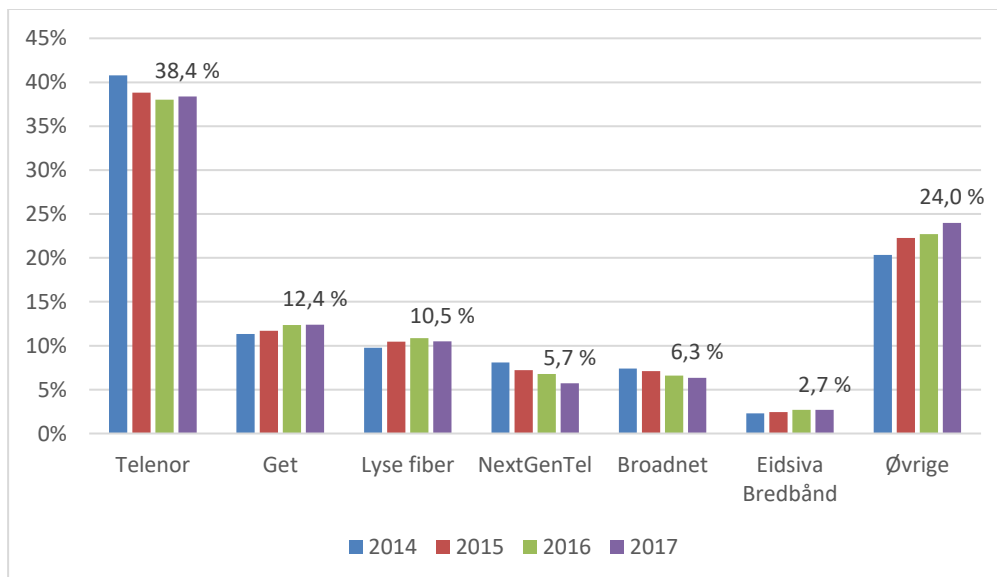

Figure 12: Market shares for fixed broadband aimed at the combined residential and business market, measured by sales revenue. (Source: Nkom's electronic communications statistics for 2017)

70. Figure 13 shows the market shares in the combined residential and business market for fixed broadband access, measured by number of subscriptions. A comparison of figure 12 and figure 13 shows that Telenor's market share is slightly higher when measured by number of subscriptions than when measured by sales revenue (39.8% compared with 38.4%). This is related to the above-mentioned difference for the two measurement methods in the business market. Similarly, it is assumed that Get's higher market share measured by number of subscriptions than by sales revenue is mainly due to the relative difference in the proportion of housing cooperative customers in the residential market mentioned above.

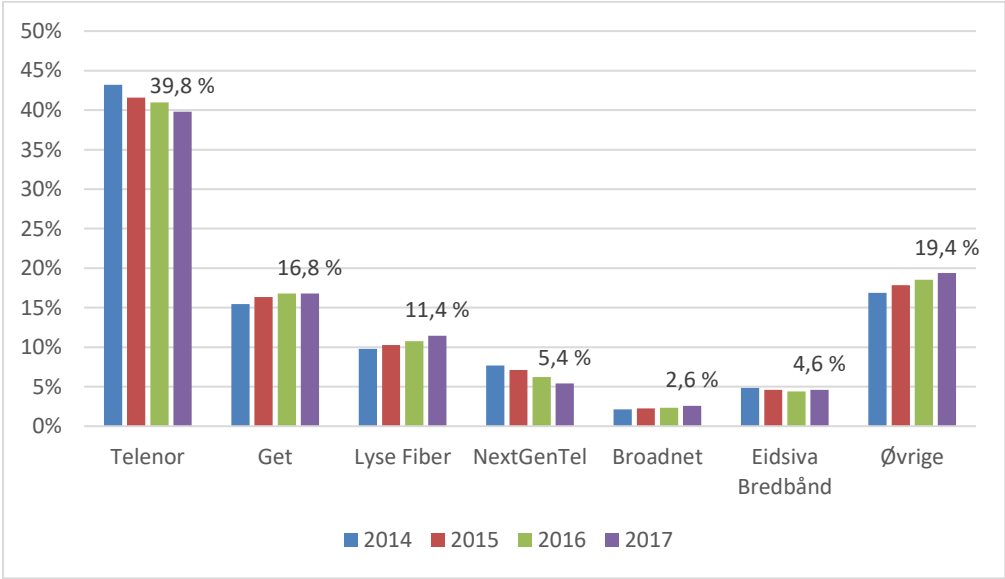

Figure 13: Market shares for fixed broadband aimed at the combined residential and business market, measured by number of subscriptions. (Source: Nkom's electronic communications statistics for 2017)

High-quality access

71. As described above, many business customers request access solutions with greater quality and/or functionality than is included in a standard broadband subscription. These are often companies with multiple locations and/or units, or companies with high demands regarding quality, availability and/or service level. These kinds of companies want capacity products such as leased lines and wavelengths / optical channels, dark fibre or data communication products such as IP VPN and Ethernet VPN, in order to establish access solutions that meet more advanced communication needs than companies that request a standard broadband subscription.

72. Figure 14 shows market shares for retail sales of capacity products, i.e. leased lines and wavelengths / optical channels, measured by sales revenue. In this context, TampNet's market share must be assessed in view of the fact that TampNet's operations are mainly intended for a delimited customer segment linked to offshore oil operations in the North Sea. This means that TampNet cannot really be regarded as a provider that affects the competitive

situation in mainland Norway, with the exception of that part of the market that includes companies in oil-related sectors.

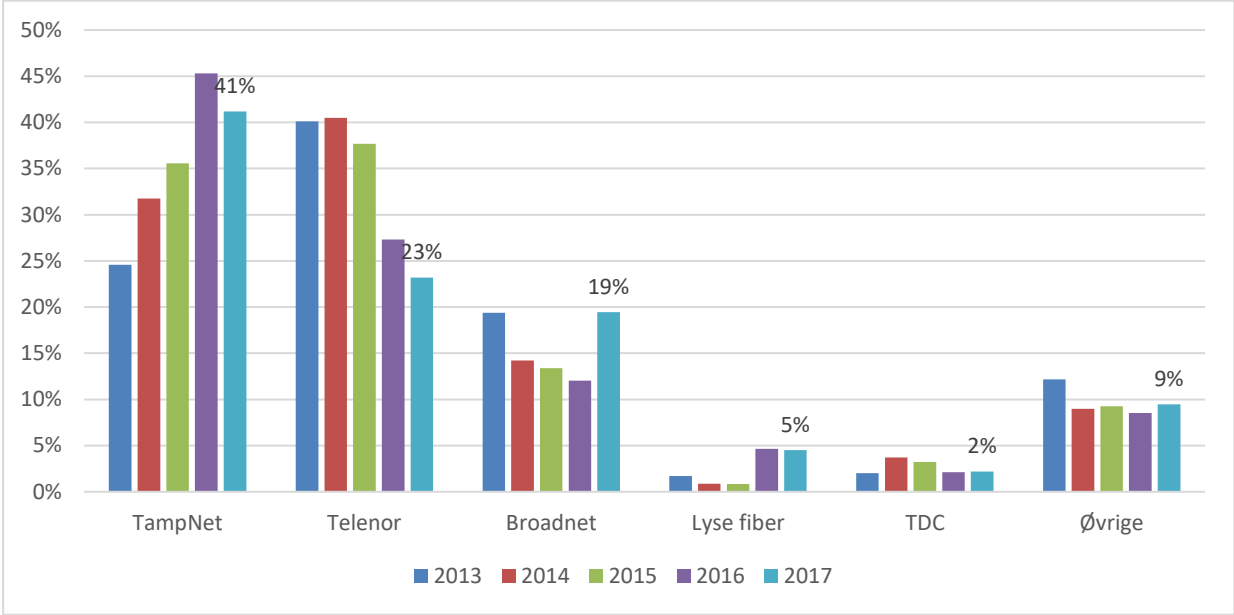

Figure 14: Market shares for retail sales of capacity products, i.e. leased lines and wavelengths / optical channels, measured by sales revenue (Source: Nkom’s electronic communications statistics for 2017)¹²

73. Figure 15 shows the market shares for retail sales of dark fibre, measured by sales revenue.

¹² Lyse Fiber’s market shares also include Signal Bredbånd and Istad Fiber. The market share figures for Broadnet also include Xfiber and Dataguard.

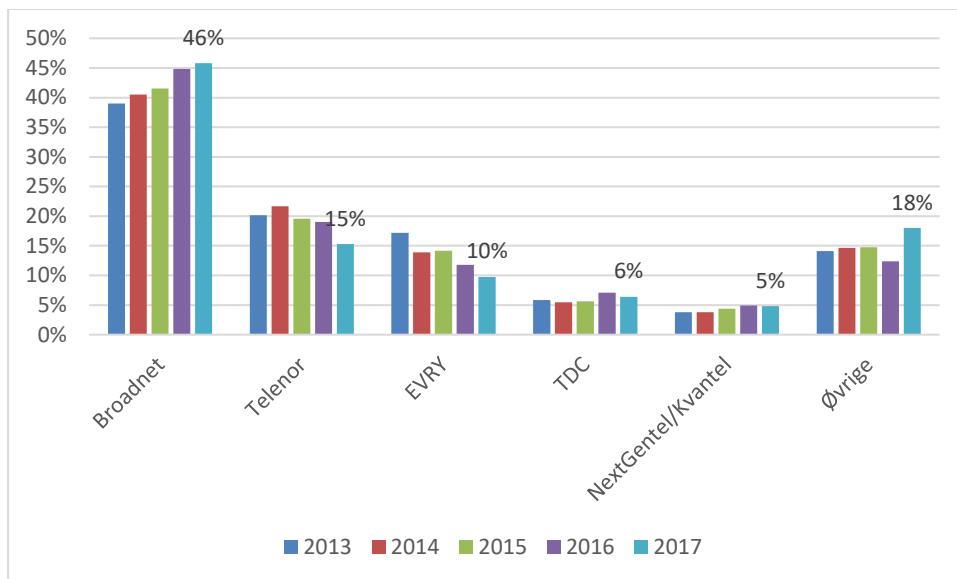

Figure 15: Market shares for retail sales of dark fibre, measured by sales revenue. (Source: Nkom's electronic communications statistics for 2017)

74. In Nkom's electronic communications statistics access solutions based on IP VPN and Ethernet VPN products are categorised as *data communication services*. Figure 16 shows the market shares based on sales revenue in this retail market.

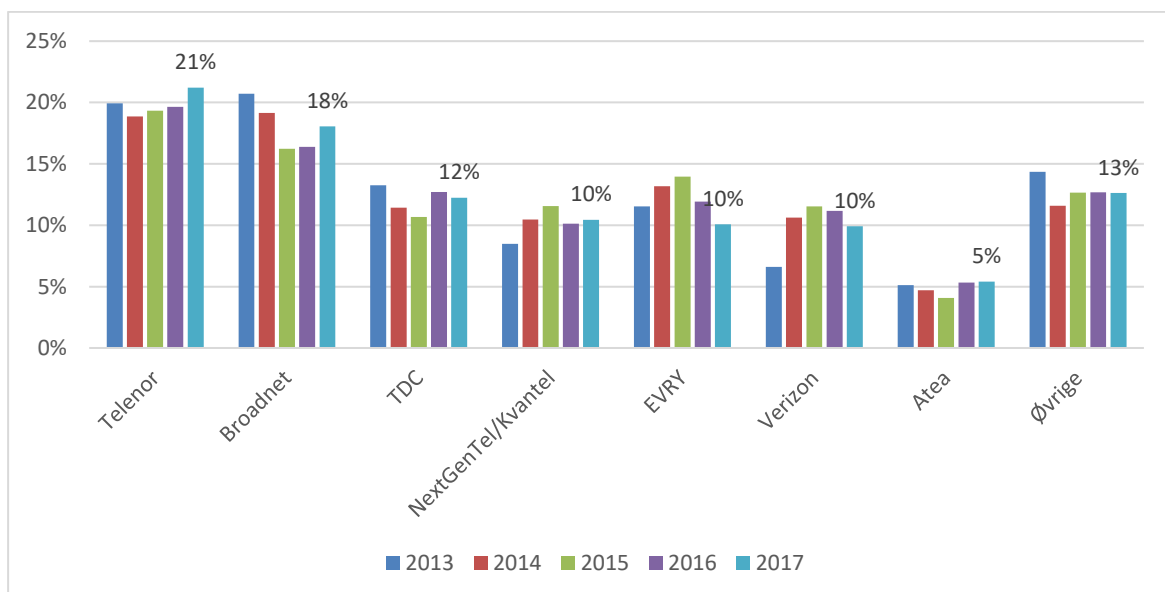

Figure 16: Market shares for retail sales of data communication services, measured by sales revenue. (Source: Nkom's electronic communications statistics for 2017)

75. According to the electronic communications statistics for 2017, total revenue from retail sales was NOK 442 million for capacity products, NOK 209 million for dark fibre, and NOK 1,736 million for data communications services. Figure 17 shows the market shares based on the providers' combined revenue from retail sales for capacity products, dark fibre and data communication services.

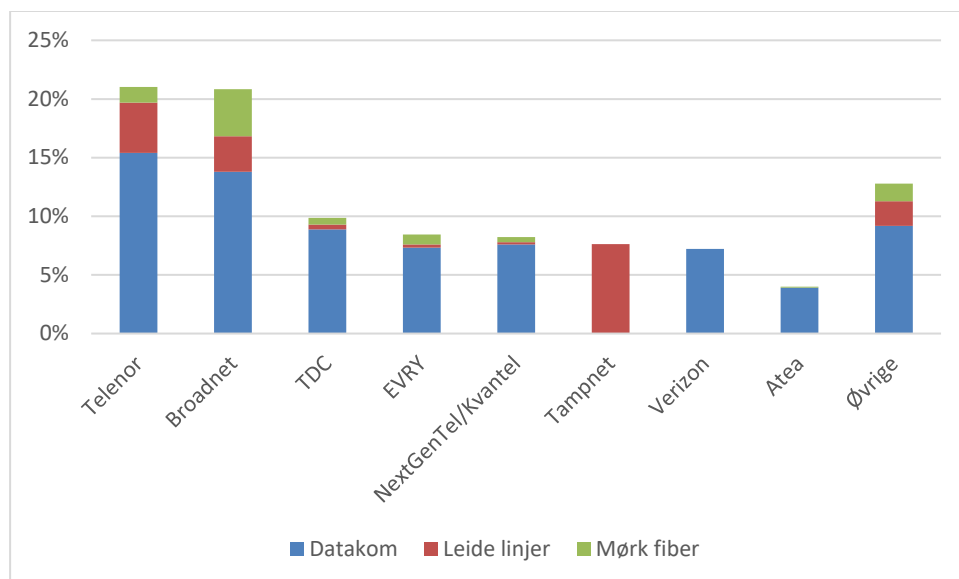

Figure 17: Market shares for retail sales of capacity products, dark fibre and data communication services, measured by sales revenue. (Source: Nkom's electronic communications statistics for 2017)

76. Figure 17 shows that no providers in this combined retail market have a market share of over 25%. Telenor, Broadnet, TDC and EVRY are the four largest providers measured by retail sales of capacity products, dark fibre and data communication combined. These four providers each have market shares of between 8 and 21%.

77. In figure 17, Tampnet's share of the sales revenue is approximately 8%. As Tampnet's operations are primarily focused on a limited customer segment related to offshore oil operations in the North Sea, TampNet cannot really be regarded as a provider that affects the competitive situation in mainland Norway, with the exception of that part of the market that includes companies in oil-related sectors. Excluding TampNet's sales of capacity products from the total retail sales of capacity products, dark fibre and data communications gives the market share distribution shown in figure 18.

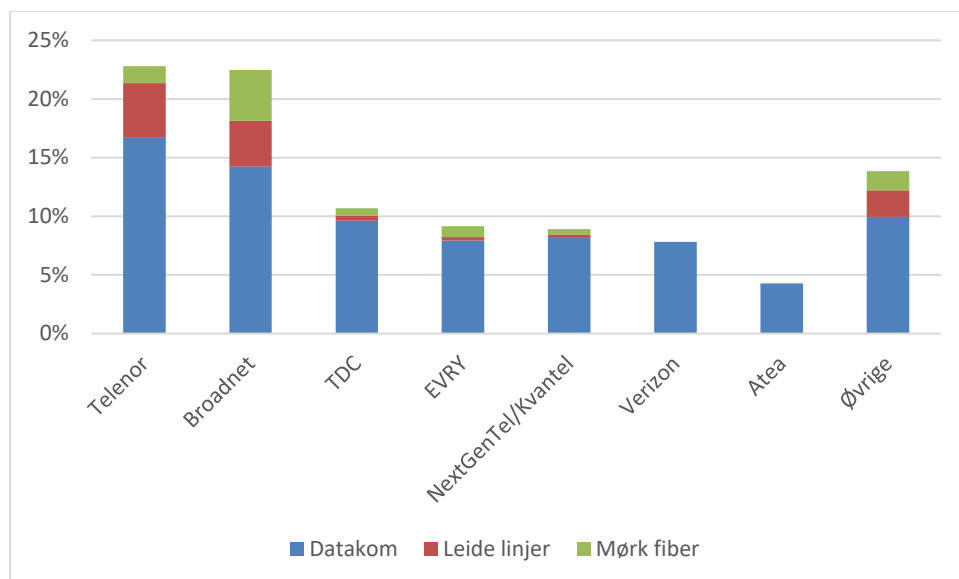

Figure 18: Market shares for retail sales of capacity products, dark fibre and data communication services, excluding TampNet's share, measured by sales revenue. (Source: Nkom's electronic communications statistics for 2017)

78. Figure 18 shows that even when TampNet's sales of capacity products are excluded, there are still no providers in this combined retail market with a market share of more than 25%.

2.2.6 Development trends in the retail market for fixed access

79. The developments in technology enable ever higher speeds in broadband networks, and the growth in the demand for high-speed broadband is expected to continue in the years ahead as a result of increased use of capacity-intensive broadband services, dynamic service development and digitalisation of ever more value chains in different sectors.

80. In consequence, Nkom expects that the roll-out of fibre around the country will continue in the next few years and that the number of fibre customers will increase. At the same time, the decrease in the number of xDSL accesses is expected to continue. It is less clear whether this decline will accelerate in the coming years or if there will be a more gradual decrease in the number of xDSL customers. Nkom assumes that the future process associated with the upgrading of Telenor's copper network, including the determination of prices and terms for wholesale access, will affect the size and rate of the decline in the number of xDSL accesses in the years to come. Regardless, it is expected that the infrastructure competition between providers that base their retail offerings on copper, HFC and fibre access will continue in the coming years. Additionally, it is assumed that in the long term the distinction between fixed network based and mobile network based access may become smaller for some areas of application and customer groups. The rate and extent to which this will happen will depend, among other things, on whether the pricing models for fixed network based and mobile

network based access converge and developments in the business models and service offerings in future 5G networks.

81. In the following Nkom has summarised the main developments on the demand side and the supply side in the retail market for fixed access.

Developments on the demand side

82. In the residential market, changing patterns of use and development of services related to household's TV consumption in particular will affect the capacity needs in broadband networks in the future. The migration from linear TV as the sole platform for TV entertainment to a situation where linear TV is competing with on-demand TV, streaming of films and TV shows, and other OTT entertainment is expected to continue in the coming years. In addition, it is also assumed that the use of video-based content in various social media will increase. Other examples of services that will drive the need for capacity in the residential market are online games with increasingly advanced graphics and cloud-based storage of video, photos, etc.

83. Strong competition on the service level in broadband networks is expected between OTT actors and access providers in the years to come. Network neutrality provides the basis for increased service diversity and increased freedom of choice for broadband customers. The consumer authorities' requirements regarding separate sales of internet access and TV packages in HFC networks will further support this trend.

84. On this basis, it will be important to pave the way for access to high-capacity broadband networks across the whole country. This is reflected in the government's electronic communications policy plan, which defines an overarching target of 100 Mbit/s coverage for 90% of Norwegian households by 2020. In the long term, the goal is for all households to have an offer of high-speed broadband.

85. In the business market and in the public sector, it is assumed that an increasing portion of service production, data processing and data storage will be cloud-based in the coming years. In addition, an increasing number of new value chains and processes will be digitised and automated. The realisation of concepts such as "smart cities" and "smart municipalities" will also increase the capacity needs in broadband networks, and the market for the Internet of Things is now starting to emerge. In sum, these trends are expected to lead to increased demand for high-capacity broadband in the business market in the coming years, in both the private and the public sector.

Developments on the supply side

86. The coverage survey for 2017 showed that around 80% of Norwegian households had access to broadband with speeds of 100 Mbit/s or more, up from 78% in 2016. Fibre coverage was 52% in 2017, while 51% had access to broadband over an HFC network. Approximately 57% of the households had access to VDSL.

87. Further fibre roll-out is expected in the next few years. Telenor has communicated a goal of doubling its market share in fibre from approximately 20% today to 40% in 2020. At the same time, Lyse and the Altibox partners are continuing their roll-out of fibre in those parts of the country where Altibox is represented, and the other local and regional fibre operators in Norway are also expected to contribute to increased fibre coverage in the next few years. However, the extent of the future fibre roll-out is uncertain. Most of the most densely populated areas in Norway already have fibre, and the remaining geographical areas are thus less attractive for fibre investments.

88. One factor that may contribute to increased fibre coverage is the roll-out of the next generation mobile network (5G). The 5G network will probably be rolled out with fibre to significantly more base stations in the mobile networks than is currently the case. The roll-out of fibre to base stations may thus provide the foundation for increased fibre coverage in the residential and business markets in the same geographical areas.

89. The upgrade of the copper network will also increase 100 Mbit/s coverage. However, the scope of this upgrade is currently uncertain. Firstly, regulatory issues may affect the scale of the upgrade of the copper network. Furthermore, investment decisions related to additional fibre roll-out by both Telenor and other fibre operators may affect the degree to which the copper network is upgraded.

90. New HFC networks are not expected to be rolled out to any significant extent. It is assumed that any new access networks HFC providers might build will be fibre networks. However, new versions of DOCSIS will increase the capacity of the existing HFC networks, and it is assumed that the competition between HFC networks and fibre networks will continue in the coming years. It is currently uncertain whether, and if so when, there will be a switch from coaxial cable to fibre in the customer accesses in HFC networks.

2.3 Definition of the product market for standardised broadband access at the retail level

91. As described in Section 2.1, Nkom will first delimit the relevant product market at the retail level, in order then to derive the relevant product market at the wholesale level.

92. The delimitation of product markets is based on the description of the market and competitive conditions in the retail market, cf. Section 2.2. In addition, Nkom's market delimitation will be based on ESA's assessments of this retail market and the accompanying description of the relevant markets, and the Commission's Explanatory Note to the Recommendation on relevant markets.

2.3.1 Delimitation between standardised broadband access and high-quality access products in the retail market

93. In the Explanatory Note, the Commission has defined one retail market for standard access products and another retail market for high-quality access products. The description of different customer segments in the Norwegian retail market for fixed access in Section 2.2 above shows that in the Norwegian market, several factors indicate that, on the basis of a substitutability assessment, it is natural to distinguish one product market for standard broadband subscriptions and another product market for access products requested by businesses in need of access solutions with greater functionality and/or quality than is provided by the standardised mass-market products.

94. Since it is functionality and quality, as opposed to price, that appear to be the most decisive purchasing criteria for businesses that want high-quality access products rather than a standard broadband subscription, Nkom assumes that a small, non-transitory price increase on high-quality products will not cause business customers to any great extent to switch from high-quality products to standard products that do not have similar functionality and quality. This indicates limited demand-side substitutability between standardised broadband access and high-quality access products.

95. In terms of supply-side substitutability, Nkom assumes that a small, non-transitory price increase on high-quality products will not lead to providers of standardised broadband access that do not already offer high-quality access products to establish such an offering as a result of the price increase to any significant degree. This is due to the fact that offering high-quality access products will require providers of standard access products to establish new processes and build new competencies linked to products, sales and delivery. The increased complexity entailed by provision of access solutions to companies with greater functionality and/or quality requirements than are afforded by the standardised mass market products indicates limited degree of supply-side substitutability.

96. Like ESA and the Commission, Nkom has concluded that there is not sufficient substitutability on either the supply side or the demand side for standardised broadband access and high-quality access products to belong to the same relevant product market. Standardised broadband access and access products requested by companies that need access solutions with greater functionality and/or quality than is provided by the standardised mass market products thus constitute two different product markets.

97. As regards the degree of substitutability between standard access products marketed separately to residential and business customers, it is apparent from the description of the different customer segments in Section 2.2 above that there are several factors that argue in favour of a high degree of demand-side substitutability between these standard access products, even if the providers themselves differentiate between offers for residential customers and business customers. This is especially true for small businesses with few

employees and without advanced broadband needs. Nkom finds that a share of these small businesses will switch to a standard residential subscription on a small, non-transitory price increase on standard business subscriptions.

98. In Nkom's opinion, there is also a high degree of supply-side substitutability related to standard broadband subscriptions marketed to the residential and business markets respectively. Although some of the providers of standardised broadband access have a primary focus on either the residential or the business market, standard broadband subscriptions are generally offered to the entire market. This implies, for example, that most providers that have initially targeted their operations towards the residential market also tend to have a standard offering for companies that do not request greater functionality and/or quality than is provided by mass-market products.

99. Like ESA and the Commission, Nkom has concluded that there is sufficient substitutability on both the supply side and the demand side that standardised broadband access marketed to the residential market and the business market, respectively, belong to the same relevant product market.

100. Against this backdrop, Nkom finds that the distinction drawn up in the ESA Recommendation between standardised broadband access and high-quality access products in the retail market is also applicable to the Norwegian market. This means that the wholesale markets for standard access products (Market 3a and Market 3b) and the market for wholesale high-quality access provided at a fixed location (Market 4) will be derived from two different product markets at the retail level.

2.3.2 Definition of the retail market for standardised broadband access

2.3.2.1 The Commission's Explanatory Note to the Recommendation on relevant markets

101. In the Explanatory Note the Commission refers to the fact that there are many access options for fixed broadband and that these can be based on copper, fibre and HFC networks. Moreover, satellite and terrestrial television networks can provide fixed broadband access capabilities, provided that these technologies have sufficient capacity and are adapted for two-way communication. In addition, wireless technologies, such as LTE, might be a substitute for fixed broadband from an end-user perspective, cf. Section 2.3.3.

2.3.2.2 Technical characteristics of various wired technology platforms

102. ADSL is offered in the end-user market with up to 26 Mbit/s download capacity, while VDSL is offered with up to 75 Mbit/s. Fibre and HFC networks allow significantly higher download capacities, and some operators currently offer broadband subscriptions with up to 1000 Mbit/s in such networks. Subscriptions based on ADSL, VDSL and HFC networks are generally offered with asymmetrical capacity, and have significantly lower upload than

download capacity. Fibre accesses, on the other hand, are mainly offered with symmetrical download and upload capacities.

2.3.2.3 No clear boundary between various groups of end users or between different services that can be delivered via the broadband connection

103. End users in the Norwegian broadband market have different capacity requirements as a consequence of different patterns of use and varying degrees of simultaneous use of several terminals/services via the broadband access. Nkom takes as a starting point that the individual end-user will assess all standardised broadband subscriptions that support the end-user's broadband consumption, and that are relatively close when it comes to pricing, as close substitutes, irrespective of access technology and capacities that it is possible to offer via the various access technologies.

104. Some end-users have consumption of broadband services which entails that ADSL, VDSL, HFC and fibre-network based broadband services might all be assessed to be close substitutes, based on the application area. For end-users that use broadband access in a way that means that the capacity requirement cannot be covered by an ADSL subscription, a VDSL-based service might be an alternative, in addition to services based on HFC and fibre networks. For end-users with a consumption of services that require higher bandwidth than is currently offered via the copper network, broadband services based on HFC or fibre networks will appear to be the only alternatives. For end-users with a particularly great need for high upload speed, broadband services based on fibre networks might appear to be the only alternative.

105. In the same way as there is no basis to draw clear and unequivocal boundaries between different end-user groups based on usage patterns and capacity needs in this end-user market, Nkom finds that there is no basis either to draw clear, unequivocal boundaries between different broadband services that can be offered and delivered via different capacities and access technologies. This can be exemplified by the streaming of films, series and sports events, which are services used by many retail customers. The capacity requirement related to the consumption of these streaming services depends on several factors, including the end-user's choice of screen to use the streaming service, the quality of the content that is streamed, and the number of simultaneous users of various services via the broadband access. There is thus no basis to define a clear limit concerning the capacity required to use streaming services via standardised broadband access. For example, some end-users might assess ADSL as not being very suitable for consumption of streaming services, while others might regard ADSL as a satisfactory alternative for their streaming consumption.

106. Even though neither the capacity requirement nor the use of various services on the broadband connection can be considered as homogeneous and consistent in the end-user market for standardised broadband access, Nkom cannot see any basis to draw clear and unequivocal boundaries between two or several groups of end-users as a possible basis for

defining different product markets based on capacity requirements or the use of various services.

2.3.2.4 Overlapping price points for products with different capacities and delivered via different technologies - Chain substitution

107. Broadband products in the Norwegian market are generally priced according to the speed offered, cf. Table 1.

	1-10 Mbit/s	11-20 Mbit/s	21-30 Mbit/s	31-70 Mbit/s	71-100 Mbit/s	101-300 Mbit/s	500 Mbit/s	1000 Mbit/s
Monthly fee (NOK)								
Fibre	329-399		358-429	449-519	499-649	508-849	558-1290	658-1529
HFC	349	399		449-499	549-649	589-669	999	
xDSL	477-488	477-538	532-588	577-688				
Number of subscriptions								
Consumer	180 190	495 932		798 668			477 022	
Business	25 218	55 411		27 581			18 234	
Total	205 408	551 343		826 249			495 256	

Table 1: Examples of monthly fees¹³ for different broadband capacities via different access technologies¹⁴ with associated number of subscriptions at the end of 2017.

108. The subscription figures for each band of capacity and each technology shown in Table 1 above supports the existence of a continuous chain of substitutability, cf. also Figures 5 and 6 in Section 2.2.3. While the number of subscriptions are indicated for categories “up to but not including”, the monthly fees cover products “up to and including” for each of the capacity bands. E.g., the volumes for capacities in the range 31-100 Mbit/s do not include 100 Mbit/s, while the price range indicated cover products up to and including 100 Mbit/s.

109. The table illustrates that there are overlapping or near-overlapping price points between the various capacity categories in the Norwegian broadband access market. Nkom believes this underpins that there is chain substitution on the demand side in this end-user market. Nkom considers it probable that, on a price increase of 5-10%, a hypothetical monopoly broadband provider with a capacity of between 11 Mbit/s and 20 Mbit/s will find that sufficiently many end-users will choose a product in an adjoining capacity category for the

¹³ Several of the providers offer discounts at 12 months' bond, both for new and existing customers.

¹⁴ Taken from the operators' websites in October 2018 and showing prices for fibre-based subscription from Telenor, Viken Fiber, Nornet, Årdalsnett, 3Net, Hammerfest Energi and Eidsiva, prices for subscription via HFC from Telenor, Get, Neas Bredbånd, Årdalsnett and Eidsiva Bredbånd, and xDSL prices (including line rental) from Telenor, NextGenTel and Homenet.

price increase not to be profitable. Nkom assumes that the same will apply on a price increase for a product in the capacity category of 31-70 Mbit/s. This entails that chain substitution exists between the capacity intervals of 11-20 Mbit/s and 31-70 Mbit/s, with the effect that the two intervals can be viewed as belonging to the same market. Even though the direct disciplining effect between products in the capacity categories of 11-20 Mbit/s and 31-70 Mbit/s may be moderate, the intermediate capacity category of 21-30 Mbit/s will have a disciplining effect for products in both the 11-20 Mbit/s range and the 31-70 Mbit/s range. In the same way, Nkom believes that products in the 71-100 Mbit/s capacity range will have a disciplining effect for both products in the 11-70 Mbit/s aggregated capacity range and for products in the 101-300 Mbit/s range.

110. Nkom has, in line with several other regulators in the EEA,¹⁵ primarily relied upon overlapping price points, also across the different technology platforms, to substantiate the existence of a chain of substitution. Nkom has not identified any clear break in the chain of substitution in the Norwegian market.

111. On the basis of the overlapping price points between various capacities and across platforms as well as significant volumes across the different capacity ranges, Nkom finds that there is sufficient substitutability on the demand side to conclude that broadband accesses based on various access technologies belong to the same relevant end-user market. In Section 2.4.5 Nkom assesses whether technological platform can form the basis for a division in different wholesale markets.

2.3.2.5 Practice from other EEA countries and the Commission

112. Generally, the Commission and other national regulators in the EEA have concluded that there is no basis to delimit the product market for standardised broadband access based on technology or capacity.

113. In conjunction with the merger between Vodafone and ONO in Spain in 2014 (case M. 7231), the Commission has pointed to how the transition to higher speeds should be viewed as technology development within a market, rather than as the development of a new market¹⁶.

114. The Swedish NRA, PTS, has in a draft decision, which has undergone a public consultation in the Summer of 2018, proposed to define three distinct retail product markets for standardised broadband access.¹⁷ ¹⁸ A main factor leading to this conclusion, is that a breach

¹⁵ E.g. Germany, Italy and Spain.

¹⁶ <https://eur-lex.europa.eu/legal-content/EN/TXT/DOC/?uri=CELEX:32014M7231&from=EN> *The Commission considers that there is a variety of different broadband speeds in the market and that broadband speeds increase, as technologies develop. The Commission notes that the increase in speeds is a sign of evolution of the market, rather than the creation of a new separate market.*

¹⁷ https://www.pts.se/globalassets/startpage/dokument/icke-legala-dokument/remisser/2018/telefoni--internet/3ao3b/utkast-till-beslut_3afiber_180618.pdf

¹⁸ The three retail products markets are i) Standardised broadband services provided over xDSL technology, ii) Standardised broadband services provided over HFC or FTTH technology, which in turn is split into services provided to single dwelling units (iia) and services provided to multi-dwelling units (iib).

in the chain of substitution has been identified by PTS, cf. section 2.3.5.3 in the draft decision. PTS considers that the fairly limited number of broadband subscriptions delivered in the capacity range 30 Mbit/s to 99 Mbit/s is an indication of a breach in the chain of substitution. No such breach can be identified in the Norwegian market: While less than 8% of the broadband subscriptions in Sweden have a capacity between 30 and 99 Mbit/s, 40% of broadband subscriptions in Norway is in this capacity category.

115. PTS has observed low diversion rates between broadband services based on copper and services based on fibre, in both directions. However, in the retail market, switching costs between different platforms may constitute a barrier to switch delivery platform for broadband. In Sweden, connection fees for fibre-based services are typically from 1500 Euros and upwards, while they are typically a third of this in Norway. Such a difference in connection fees are likely to have an impact on diversion rates both from copper based services to fibre and from fibre-based services to copper.

116. Nkom believes that the key factors that PTS's preliminary conclusion are based on do not apply in the same way in the Norwegian market. It should also be noted that the Commission is yet to assess the notification of the PTS decision, which will happen only after the consultation inputs have been considered by PTS.

2.3.2.6 Supply-side substitutability

117. Within products/capacities that can be offered on the individual technology platform, the access buyer can offer a range of different capacities, e.g. by changing the selected product profile on bitstream or by reconfiguring line cards using own DSLAM.

118. In the event of demand for capacities lying outside the spectrum that can be offered on the existing technology platform, supply-side substitutability will have a smaller impact: The access buyer will have to build its own infrastructure or purchase access to other infrastructure, and to ensure scale benefits any such technology change will often have to be implemented for all end-users in an area.

119. Nkom concludes that there is a high degree of supply-side substitutability between various capacities that can be delivered on the same technological platform, but less between different platforms.

2.3.2.7 Conclusion

120. Nkom cannot see any evidence of a break in the substitution chain between various fixed-broadband speed categories, which would otherwise provide a basis for defining several product markets. This indicates that there is a sufficient degree of demand-side substitutability for all products based on all relevant wired access technologies for fixed broadband connection to be included in one and the same end-user market for standardised broadband access. With regard to supply-side substitution, this is also strong between various products within a technical platform.

2.3.3 Delimitation against mobile broadband and fixed radio access in the retail market for broadband at a fixed location

121. In the market analysis from 2014 Nkom concluded that broadband accesses based on a mobile network via EDGE / UMTS / HSDPA / LTE networks and CDMA networks are not sufficiently substitutable with fixed / location-bound broadband accesses, from an end-user's perspective, for mobile network based broadband access to be included in the relevant retail market. Fixed radio access (point-to-point and point-to-multipoint connections) were, however, considered to be part of the relevant retail market.

122. In the Explanatory Note to the Recommendation on relevant markets, the Commission refers to the fact that mobile broadband accesses based on 3G technologies are not usually considered to be a substitute for fixed broadband, but a new assessment must be made when the LTE-Advanced Carrier Aggregation technology is rolled out:

“In addition, from an end-user's perspective, services provided over non-fixed-line technologies (WiFi, WiMAX, mobile) may, under certain circumstances, also be regarded as a substitute for services over fixed infrastructures. However, mobile broadband based on 3G technologies has so far from a demand-side perspective generally not been found substitutable to fixed broadband, with limited exceptions in certain Member States. The main reason has been the fact that mobile services are designed with the mobility aspect in mind and would therefore usually not allow comparable maximum speeds and bandwidth. In addition, service reliability and resilience are usually lower, to a degree that makes consumers look at them presently as complements rather than substitutes in most settings. However, from a forward-looking perspective, the current lack of substitution might have to be re-assessed in the light of the announced widespread introduction of LTE technology, the pace of which will vary across Member States.”

123. Mobile network based broadband access via 3G and 4G networks enables the end-user to consume broadband content without access to fixed broadband access. This can be done through a mobile subscription, mobile broadband subscription, an additional SIM card, or a modem linked to a computer. Download and upload speeds depend on coverage, frequency type, signal strength, distance from a transmitter, time of day, and how many people are connected to the relevant base station.

124. Over the last few years, there has been a substantial increase in the coverage area, capacity and consumption of mobile data. Both Telenor and Telia have expanded their LTE networks, and in 2014 both operators launched 4G via new frequencies, further improving coverage. In 2015, ICE also upgraded its entire mobile broadband network from 3G to 4G technology. In addition, in 2015 Telenor and Telia launched further roll-out of the LTE network, a faster version of the 4G network, also known as 4G+. This is primarily to improve standard

4G coverage, as the total amount of data traffic usage is better distributed in the network. Both Telenor and Telia have passed 95% population coverage for 4G.

125. The operators in the mobile market offer mobile broadband subscriptions with different data volumes where the data included can range from 1 to 200 GB per month. Prices range from NOK 99.5 to NOK 899 per subscription per month. The providers' upload and download speeds vary somewhat. Table 2 shows some examples of products offered in the market in June 2018 and their prices.

Monthly price (NOK) and data included (GB) per month	5-7 GB	10-15 GB	30-40 GB	50 GB	100 GB	200 GB	300 GB
Mobile broadband	99.5-229	149.5-349	199.5-499	249.5-549	299.5-699	349.5-899	399.5

Table 2: Monthly prices for national subscription offers for mobile broadband.¹⁹

126. Dedicated subscriptions for mobile broadband were introduced in 2006, and the number of these kinds of subscriptions rose gradually until 2012. Since the introduction of fixed-price subscriptions with a defined amount of voice, SMS and data included, which also made it more normal to use mobile phones for data traffic, the number of dedicated mobile broadband subscriptions has gradually declined to just over 400,000 at the end of 2017.

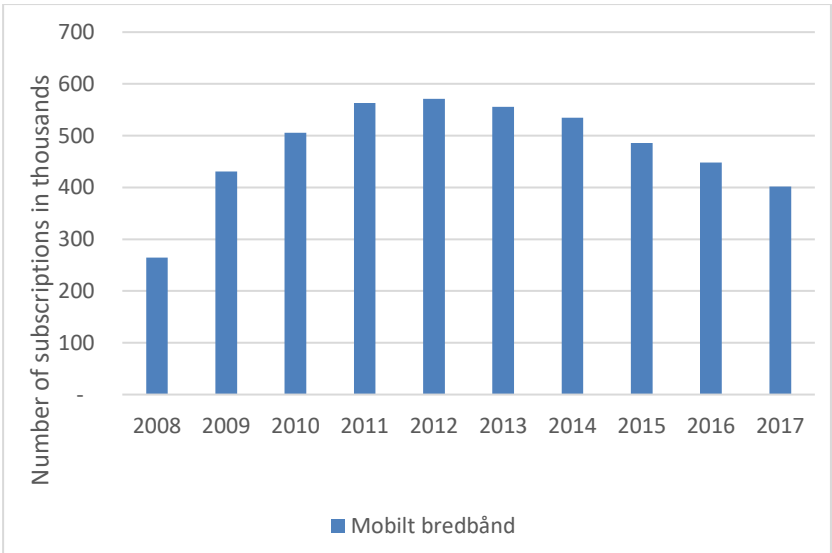

Figure 19: Development in number of subscriptions for mobile broadband. Residential and business subscriptions. (Source: Nkom's electronic communications statistics for 2017)

127. Figure 20 shows that there has been significant growth in data traffic via mobile telephony and mobile broadband in recent years. Nkom's impression is nevertheless that most

¹⁹ Taken from the operators' websites in June 2018 and showing the prices for mobile broadband subscription from the operators Telenor, Telia and ICE.

end-users regard mobile broadband as a supplement to fixed network based broadband access, but not as a substitute for fixed broadband access. However, Nkom sees that in some cases mobile broadband could be a substitute; for example, for some user groups in areas where fixed broadband has not been rolled out or for students living at a temporary address for a limited time. Increased penetration of LTE supports this, but not enough to allow the services to be regarded as in the same market.

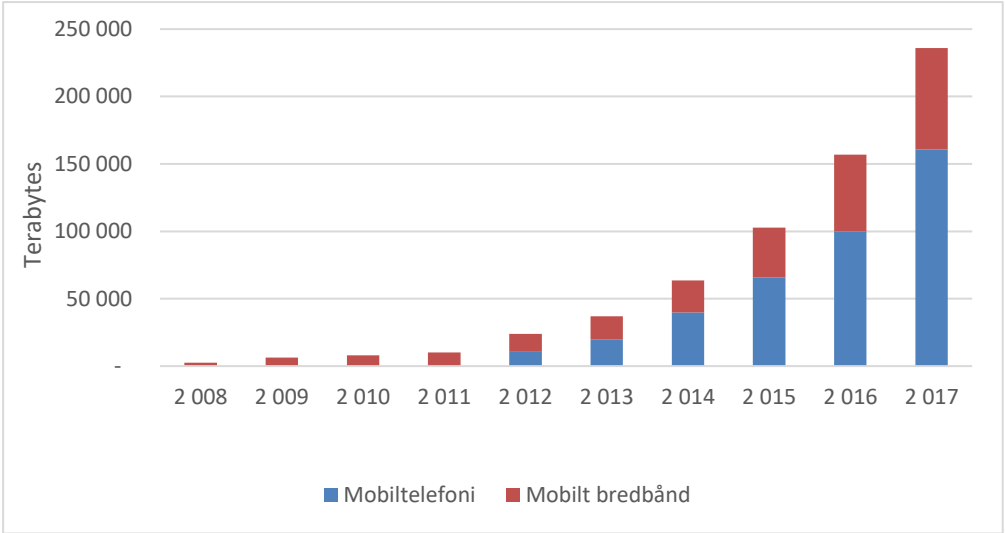

Figure 20: Development in the data traffic for mobile telephony and mobile broadband. Residential and business. (Source: Nkom’s electronic communications statistics for 2017)

128. Unlike fixed broadband products, most mobile broadband products limit how much data can be downloaded per month, especially in the residential market. In addition, for most mobile broadband subscriptions, the price will increase or the speed will be set to a minimum when the data is used up.

129. In some areas fixed broadband accesses will provide higher bandwidth and probably also be more stable than mobile broadband, as transmission capacity does not depend on the extent of other use in the same area and the distance to the nearest base station in the same way. For broadband-based services such as TV, video or online gaming, high capacity and short response times are essential for a good end-user experience. These kinds of services also require relatively large volumes of data.

130. Conversely, fixed broadband access cannot be a substitute for mobile broadband access, since fixed broadband access does not provide the same possibilities for mobility and access to broadband content at other locations than where the broadband connection is established. One of the main reasons why end-users choose to buy a mobile network based broadband subscription is because they want to be able to consume broadband content and send and receive data traffic regardless of where they are. On this basis, an assessment of demand-side substitution in the retail market indicates that broadband access based on a

mobile network and access based on a fixed network constitute different relevant product markets.

131. In a forward-looking perspective, there is reason to believe that developments in mobile networks will result in parts of the production of mobile broadband and fixed broadband converging, which could reduce the investment associated with switching from supplying mobile broadband to supplying fixed broadband. However, at present there will still be substantial investments associated with such a transition, primarily related to the necessary roll-out of access networks. Therefore, a provider of mobile broadband will not be able to offer fixed broadband without incurring significant additional costs and risks. It is therefore unlikely that a small, non-transitory price increase on fixed broadband will lead to many providers of mobile broadband switching to supplying fixed broadband. Against this backdrop, an assessment of supply-side substitution in the retail market indicates that mobile network based and fixed network based broadband access constitute different relevant product markets.

132. Fixed radio access (point-to-point and point-to-multipoint connections) differs from mobile broadband access, as radio access has location-bound application similar to cable-based access technologies (copper, fibre and HFC networks). Fixed radio access has the same characteristics as the cable-based access technologies, from the end-user's point of view, and Nkom therefore finds that broadband access based on fixed radio access is part of the relevant product market.

133. On this basis, Nkom has concluded that broadband access based on fixed radio access is part of the relevant retail market. However, broadband access based on a mobile network is not sufficiently substitutable with fixed broadband access from an end-user's perspective for mobile network based broadband access to be included in this relevant product market.

2.4 Delimitation of the derived product markets at the wholesale level

134. In Section 2.2, Nkom concluded that there is not sufficient substitutability on either the supply side or the demand side that standardised and high-quality access products can be regarded as belonging to the same relevant retail market. Nkom finds therefore that ESA's recommendation applies to the Norwegian market situation. This implies that one retail market is defined for standardised broadband access and another retail market is defined for high-quality access products. In this section, Nkom will derive the relevant product markets at the wholesale level based on the retail market for standardised broadband access.

135. It follows from Section 2.3.2 that Nkom has included all fixed access technologies in the retail market for standardised broadband access. Also in the market analysis from 2014, Nkom concluded that all relevant fixed access technologies, including the copper-based access network, HFC networks, fibre access networks and radio access networks for fixed broadband connections, were to be included in the wholesale market for LLU (former Market

4). Moreover, Nkom concluded that vertically integrated companies' internal sales or use of access lines were to be included in the LLU market. In the wholesale market for Broadband Access (former Market 5), Nkom concluded that all wholesale provision of broadband access products delivered via fixed access networks, including vertically integrated companies' internal sales or use of access lines, should be included.

136. Broadband providers that want to offer broadband services to residential and business customers rely on access to access network infrastructure and active network equipment for transmission and communication. Broadband providers that do not have their own access network to their end customers can invest in a new access network infrastructure (copper, fibre, HFC, fixed radio access). Having an own access network gives the broadband provider great freedom in the development and productification of broadband services, as well as a high degree of financial and technical control over production, but requires major investments. Alternatively, a broadband provider can gain access to access connections by purchasing access from another access network owner offering wholesale services.

2.4.1 Different types of wholesale services

137. Wholesale services can be produced with varying degrees of refinement of technical functionality. Wholesale access can be offered with a high degree of refinement of technical functionality from a wholesale provider, either in the form of access connections between the broadband service provider's own IP network and the end user or through a complete offer of access for resale to end users. The interface for access to services with a high degree of refinement of technical functionality is normally located at the central level in the network. Wholesale access can also be offered as an unrefined product or a service with a low degree of refinement of technical functionality. This can be physical access or a virtual connection at layer 2 of the Open Systems Interconnection (OSI) model (see the explanation below). The interface for access to these kinds of services is at the local level in the network. Purchasing services with a low degree of refinement of technical functionality requires that the broadband provider must make investments in its own network and active network equipment in order to be able to provide services in the retail market. This is particularly true in connection with purchase of physical access. The broadband service provider's ability to control and develop its own retail services increases in line with the degree of refinement that the provider is responsible for.

138. The OSI model can be used to explain the structure of network communication and will be referred to in the more detailed description of the markets below. Nkom will therefore provide a brief description of this model.

139. The OSI model is a reference model that shows how applications can communicate over a network. A reference model is a conceptual framework to help us understand and describe functionalities. The purpose of the OSI model is to guide suppliers and developers so that digital communications products and applications work together, as well as to enable clear

comparisons between different communication tools. The OSI model consists of seven layers (see figure 21), and each layer contains a specific functionality that is independent of the technique used in the layer above or below. Layer 1 conveys information via an electrical or optical interface with a physical medium, such as a cable, microwaves, or fibre optics. Layer 2 formats data in frames for transmission between two network elements, i.e. a link. A “frame” is the basic data unit transferred at the data link level. Error detection and correction take place at the data link layer. At layer 3 data are routed between network devices in the form of packets. A “packet” is the basic unit of data that is transmitted between network layers on two nodes. Layers 4 to 7 are where end-to-end communication takes place, and functionality is implemented in the end-user equipment. These layers are not described here.

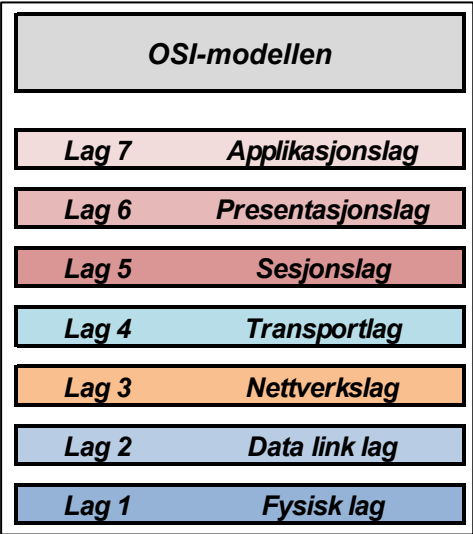

Figure 21: The Open Systems Interconnection (OSI) model.

140. A wholesale service that is refined in such a way that it, in principle, corresponds to a retail service, will be a layer 4 (transport) service in the OSI model. The operator that produces these kinds of refined products will control most of the technical parameters and thus also the design of the retail service. A wholesale customer that buys this kind of highly refined service has extremely limited possibilities to differentiate the retail service in terms of technical and financial aspects

141. Wholesale customers that want more control over the content in their broadband services may instead choose to purchase a virtual access connection available at the layer 3 (network) level. However, unlike the purchase of even more refined products on layer 4, the wholesale customer must invest in own active network equipment to handle, among other things, the end user’s connection to the internet.

142. Any virtual access connection at the layer 2 level of the OSI model (the data link level) gives wholesale customers even greater opportunity to design their retail services, because the wholesale customer controls the transfer at the layer 3 (network) level itself. Physical access connections to network infrastructure means that the wholesale customer gains access

to network infrastructure by buying physical connections at the cable level between the wholesale customer's own network and the end customer. Wholesale customers that choose to purchase physical access connections must invest in and place their own active equipment at both ends of the cable, and these can only be used locally, close to the end user's location. However, unrefined services provide wholesale customers with good opportunities to control and differentiate their retail services themselves.

143. Some providers in the retail market currently purchase wholesale access at the local level in the network, such as the product Operator Access with connection in Telenor's local exchanges, or produce local access through their own access network. Other providers buy wholesale access at the regional and/or more central level of the network, for example through Telenor's Jara DSL or VULA Fibre products. Many providers buy access at both the local and the regional or central level, sometimes also in combination with their own access network. The ESA Recommendation distinguishes between local access and central access.

144. On the basis of the ESA Recommendation, in this section Nkom will define the relevant product markets for standardised broadband access at the wholesale level (Market 3a and Market 3b). The starting point is the retail market for standardised broadband access as described in Section 2.3.2.

2.4.2 Assessment of the distinction between the market for wholesale local access and the market for wholesale central access

145. In its previous analysis of the wholesale markets for LLU (former Market 4) and Broadband Access (former Market 5), Nkom concluded that, although there may be some degree of substitutability on the demand side, the different opportunities to differentiate the retail product, different degrees of investment risk and different connection points in the network indicate that there are no grounds for concluding that LLU and Broadband Access are part of the same relevant market.

146. The Explanatory Note to the Recommendation states that in a forward-looking perspective, it is more appropriate, based on a substitutability assessment, to differentiate between local access in Market 3a and central access in Market 3b, instead of the traditional distinction between physical and virtual access products that has previously formed the basis for the delimitation between the wholesale markets for LLU and Broadband Access. The Commission refers to the fact that growth in the roll-out of Next Generation Access Networks (NGA) will continue in the coming years with regard to areas covered. At the same time it is expected that upgrades of copper-based technologies will help extend the useful life of copper-based systems and provide end users with access to high-speed broadband services, including from wholesale providers. Several important aspects of the products must be assessed in order to distinguish between the two wholesale markets:

- connection point (local versus non-local access),
- the topology and transmission properties of the wholesale product, and

- the degree of flexibility that the access product allows the buyer of access to differentiate its retail offerings, compared with the wholesale provider's retail offering.

147. The recommendation concludes that in order to reflect the change in the market, the national regulatory authorities should distinguish between the wholesale market for access at local level, Market 3a, which comprises access to products that grant access buyers both a handover point at local level in the network, and opportunities for greater and more flexible control of the access lines; and the wholesale market for centralised access, which comprises access to products that either have a handover point at central level in the network, or give access buyers less direct control of the access line than in Market 3a, i.e. a more standardised product.

148. In the light of the fact that the Commission and ESA distinguish between local and centralised access, and that this distinction to some extent depends on national conditions, development strategy and technology choice, there is a need to clarify what Nkom considers to be local and centralised connection points, respectively.

149. For the copper access network, Nkom considers connection at, or in the immediate vicinity of, the main connection (either in the local exchange at the remote subscriber stage "RSx" or the underlying distribution point) to be local connection.

150. For fibre networks based on point-to-point technology, Nkom considers connection at the same location as "Optical Line Termination" (OLT) to be local. This is also the case where the OLT is further away from the customer than the local telephony exchange serving the area. For fibre-based networks where access closer to the customer than OLT is possible, any such connection will also be local. Connection at a higher level in the network than OLT is considered to be centralised access in a point-to-point network.

151. Technical characteristics of a fibre network based on point-to-multipoint technology (e.g.. Gigabit Passive Optical Network, GPON) enable the delivery of service to customers further away from the "fibre exchange" than is possible for services delivered via copper. This entails that newly-built ODF (Optical Distribution Frame) points could be rather more centrally located in the network than the main telephony connections ("MDF").

152. In the Commission's "Staff Working Paper for SMP Guidelines"²⁰ (page 14), reference is made to how in its practice the Commission has deemed that virtual access products may be part of the same relevant market as a physical access product, provided that they have functionality equivalent to or comparable with physical access.

153. The Commission refers, among other things, to its decision in case DE/2016/1876: The Commission questions that the German regulator, Bundesnetzagentur, on the one hand considers that a virtual access product at BNG (Border Network Gateway) level does not fulfil the requirements for access products in Market 3a, but on the other hand maintains that the

²⁰ http://ec.europa.eu/newsroom/dae/document.cfm?doc_id=51927

lapse of opportunities for physical access can be compensated with an active layer-2 product at BNG level. Commission also points out that a conclusion in this matter cannot be drawn until the functionality of the layer-2 product has been completely and finally determined.

154. Furthermore, the Commission has recently, following a notification of a draft decision in the Netherlands, accepted that virtual access in Market 3a is given at around 160 points. This is based, among other things, on how the network structure will be more unstable closer to the end-customers due to the planned discontinuations of the telephony network in individual areas. Nkom finds that this argument also may apply in the Norwegian context.

155. In the Spanish market, too, the Commission has accepted “Metropolitan Points of Presence”, which constitute the transition point between the access and core networks for an NGA operator, as a connection point for virtual local access.

156. For fibre networks based on point-to-multipoint technology, Nkom therefore considers connection at BNG-level to be the local connection level. This applies regardless of whether OLT is at the same location as BNG or not.

157. Nkom also points out that the Commission has laid down several criteria for an access form to be included in the market for local access. This means that a virtual access product that has a local technical connection level, cf. above, does not belong to Market 3a unless the other requirements are also met, cf. Section 2.4.3.

158. Nkom believes that recent technology development, with more extensive use of Ethernet technology, means that the relation between technical connection level in the network and the access buyer's opportunity for flexibility and management of service offerings is less clear than before. This may affect how the distinction between Market 3a and Market 3b is drawn regarding connection level.

159. Products in Market 3a will always have a technical connection at what is regarded as local level in the network. Products in Market 3b will usually have centralised access as the technical connection level, but may also be based on local technical connection level in the network. Unless the context indicates otherwise, “local access” refers to products in Market 3a, while “centralised access” refers to products in Market 3b.

160. Parts of the demand side in the market for wholesale broadband access products in Norway use access on both the local and central level as wholesale inputs for their retail offerings. Traditionally, the number of end users per subscriber exchange has been decisive for the access buyer's choice between local or central level access. In isolated terms, having more customers per subscriber exchange will suggest using access at the local level, since the access seeker will then be able to achieve economy of scale because costs can be distributed among more customers. Hence, this is also likely to lead to an increased level of demand side substitutability between local level and central level wholesale access for a wholesale customer that buys central access.

161. If the starting point is a wholesale customer that buys local access, and has already invested in equipment and built up an organisation to use local access as a wholesale input for retail services, switching to wholesale central access as the form of connection might not be very attractive. For these wholesale customers, there might be little substitutability between wholesale access at the local level and at the central level. However, this may change if the customer basis per subscriber exchange is reduced.

162. Although there may be some degree of substitutability on the demand side, Nkom has nevertheless concluded that the different opportunities to differentiate the retail product, different degrees of investment risk and different connection points at the local and central level in the network mean that wholesale local access and wholesale central access belong to different relevant wholesale markets.

2.4.3 Assessment of Market 3a Wholesale Local Access criteria for each technology platform

163. It is stated in the Explanatory Note (page 42) that the market for wholesale local access is primarily comprised of physical wholesale products that enable broadband access in the retail market:

“At present the WLA [Wholesale Local Access] market primarily consists of physical or passive access products enabling transmission of internet and related data services.”

164. The Commission further notes that physical access to copper networks is the most common form of access in the EU, but that experience to date does not indicate that there are any significant breaks in the chain of substitution between copper-based and fibre-based broadband services and that fibre-based products ought therefore to be included in the market for wholesale local access:

“So far experience under the Article 7 procedure has not shown significant breaks in the chain of substitution when comparing current-generation broadband services to those provided over optical fibre. Therefore, access to a FTTH, FTTB or FTTC/VDSL (either point-to-point or point-to-multipoint) network should be considered as functionally equivalent to traditional copper LLU. In this respect, NRAs should include in the WLA market all access products available at the physical layer in a point-to-point FTTH architecture, in a point-to-multipoint FTTH architecture or in FTTC/VDSL scenarios (e.g. ODF unbundling access, cabinet unbundling access, access to the terminating segments at the concentration/distribution points).”

165. The Commission believes that there may be a need for virtual access products at the local level, in cases where either wholesale access to the physical infrastructure is not financially viable or technically possible or where it is not possible to carry out an upgrade of the network at the same time as previous access to a physical wholesale product at the local

level is maintained. The Commission deems it appropriate that virtual products are also included in the market for wholesale local access when such products have characteristics that correspond to or are comparable to the characteristics of the physical wholesale products at the local level:

“However, in situations where fibre physical unbundling is not technically or economically feasible or where the implementation of SLU unbundling [copper sub-loop unbundling] would impede the realisation of the full benefits of VDSL2 vectoring (see section 4.4.2.2), NRAs have been mandating virtual access products as a more proportionate remedy without prejudice to future technological developments which may allow physical unbundling under appropriate conditions.

Against this background, it appears appropriate also to include access based on non-physical or virtual products in the WLA market when they exhibit functionalities equivalent or comparable to the key features of physical unbundling.”

166. Against this backdrop, Market 3a is based on former Market 4, but is now being expanded to also include non-physical, virtual wholesale products whose functionality, from the wholesale customer’s standpoint, is equivalent to today’s products in former Market 4.

167. It is also stated in the Explanatory Note (page 43) that non-physical, virtual wholesale products in Market 3a shall have the following characteristics:

- *“Access occurs locally. This means that traffic is handed over at a level which is much closer to the customer premises than access at the national or regional level as generally granted with traditional bitstream access. Such “localness” is typically given in a scenario where access is granted at or close to the central office/MDF (including newly built ODF) or the street cabinet. ...”*
- *“Access is generic and provides access seekers with a service-agnostic transmission capacity uncontended in practice, i.e. providing guaranteed bandwidths according to the access seekers’ needs, whereby respective access requests are subject to the principle of proportionality, and would normally not require the SMP operator to deploy new physical infrastructure. ...”*
- *“Access seekers need to have sufficient control over the transmission network to consider such a product to be a functional substitute to LLU and to allow for product differentiation and innovation similar to LLU. ...”*

168. Local access implies that the connection point is close to the end users’ premises. For physical access, access can take place in a local exchange or a remote unit / node from a local exchange. For virtual access, there may be fewer access points than exchanges, i.e. that access can be given at a slightly more aggregated level. The wholesale customer will be able to transport traffic on to more central points in the network, either via its own network or by purchasing transport services from a wholesale provider.

169. In this context, service independence means that the wholesale customer has the opportunity to differentiate its service offerings compared with rival providers in the retail market, and that there are no system-technical aspects of the wholesale product that might restrict this possibility. The requirement that the connection must be uncontended means that the capacity of the connection between the termination point at the end customer and the connection point is only limited by the inherent capabilities of the access technology deployed.

170. Control over the connection means that the wholesale customer controls the connection to the end customer and that the wholesale customer in theory has full flexibility to develop and provide end-user services via the connection. For local-level virtual connections, the wholesale customer will not necessarily have full control over the connection, but will still be given the opportunity to, inter alia, monitor the connection, and set and change quality-of-service parameters.

2.4.3.1 Definition and delimitation of Market 3a

171. In connection with the delimitation of Market 3a, Nkom has assessed whether physical access at the local level can be granted and/or whether the above-mentioned characteristics that define virtual products in Market 3a are met in copper networks, fibre networks, HFC networks and fixed radio access networks, respectively.

The copper network

172. Physical access at the local level in copper-based networks is the starting point for the definition of Market 3a. The regulation of former Market 4 (LLU access) has enabled local, physical access for wholesale customers in Telenor's copper network. LLU access has been characterised by the fact that wholesale customers have had control over the connection and have had the opportunity to monitor the connection and to make changes in the speed of the individual access connection, etc.

173. Through local, physical access to the copper network, wholesale customers have also had full control over the connection. At the same time, the wholesale customers in the LLU market have not had restrictions as to what services they can offer in the retail market. Thus, local physical access to the copper network has facilitated service independence in the form of the opportunity to differentiate service provision in relation to rival offerings in the retail market.

174. On this basis, Nkom finds that the regulated copper products for physical access that were previously included in former Market 4 are part of the relevant market for wholesale local access.

175. It also follows from the Explanatory Note that virtual wholesale products with similar or comparable properties as the regulated physical products will also be considered to be part of Market 3a. Technological developments, including the upgrading of Telenor's copper network, may enable virtual wholesale products in the copper network in the next few years that meet the criteria for Market 3a products.

176. On this basis, in principle both physical access at the local level and any virtual wholesale products in copper networks that meet these criteria will be part of Market 3a.

Fibre networks

177. The regulation of LLU access in former Market 4 also includes the obligation to meet reasonable requests for physical access to fibre networks at the local level. As with LLU access in the copper network, Nkom believes that physical access to systematically developed point-to-point fibre access networks, which up until now have been covered by the regulation in former Market 4, is part of Market 3a.

178. Nkom also believes that in principle any physical access at the local level to the systematically rolled out point-to-multipoint fibre access network or passive optical network (PON) will also be part of Market 3a. The technological developments mean that an assessment of the difference between point-to-point networks and passive optical networks may become less straightforward in the years ahead than has been the case to date.

Wavelength-division multiplexing (WDM) technology allows different data streams to be sent simultaneously over a single optical fibre. This may mean that wholesale customers in a passive optical network can be given the opportunity to place active equipment at the optical distribution frame (ODF) level, in the same way as in a point-to-point network. WDM technology is currently mainly being considered for use in the backbone network, but can, technically, also be used in access networks. It is therefore possible that WDM technology will also be deployed in access networks within the time horizon of this market analysis; in which case, it would give wholesale customers the possibility to collect all the traffic locally at the ODF level in passive optical networks. In this context, it is interesting to note that the Danish Business Authority has concluded that access in the form of this kind of local accumulation of traffic at the ODF level in passive optical networks is part of Market 3a.

179. On this basis, Nkom concludes that any physical access at the local level to systematically developed fibre networks shall, in principle, be regarded as part of Market 3a.

180. In the same way as for the copper network, virtual wholesale products for access to the fibre network, with similar or comparable properties as the regulated physical products will also be considered to be part of Market 3a. Technological developments can enable virtual wholesale products in the fibre network in the next few years that meet the criteria for Market 3a products. Even though Telenor's existing wholesale product, VULA fibre, can be deemed to have a local connection level (connection on BNG), the product does not fully meet the other criteria for local access and is therefore not included in Market 3a.

181. Therefore, in principle, both wholesale products for physical local access to a fibre network and any virtual wholesale products for access to a fibre network that meet the aforementioned criteria will be part of Market 3a.

HFC networks

182. In the case of wholesale products for broadband access via an HFC network, it is stated in the Explanatory Note (page 44) that the Commission does not consider it likely that HFC networks represent such a strong competitive factor for local wholesale products in copper and fibre networks that there are grounds to include HFC networks in Market 3a. At the same time, the Commission points out that this must be considered in a forward-looking perspective and refers specifically to the planned upgrade to DOCSIS 3.1 in HFC networks.

183. Like the Commission, Nkom cannot see that there are grounds to include HFC networks in Market 3a, given the above-mentioned criteria, all of which must be met for a virtual access product at the wholesale level to be regarded as being part of Market 3a. Although broadband access via an HFC network represents a significant competitive factor in the Norwegian retail market for standardised broadband access, and roughly 1/3 of broadband customers today purchase broadband access via an HFC network, neither physical access at the local level to an HFC network nor virtual wholesale access that meets these criteria, is regarded as technically or commercially feasible within the time horizon covered by this analysis. In particular, the characteristics “control over the connection” and “uncontended connection” are regarded as being unrealistic at the wholesale level in HFC networks in the next few years.

184. Nkom would also like to point out that neither the Danish Business Authority nor the Swedish Post and Telecom Authority (PTS) have found grounds to include HFC networks in Market 3a. For example, in its assessment of this matter, the Danish Business Authority concludes:

“It is the Danish Business Authority’s overall assessment that wholesale products that can be provided via an HFC network do not meet criteria for local network access. As a result of the structure of the networks, access to physical connections is technically and commercially unrealistic, and establishment of virtual products, which could meet the criteria, are not currently considered to constitute a technically applicable option.

It is thus the Danish Business Authority’s assessment that HFC networks are not encompassed by the relevant product market.”

185. It should also be noted that ComReg in Ireland has chosen to conduct an external assessment of whether access to HFC networks can be said to comply with the requirements for wholesale products in Market 3a as follows from the Explanatory Note. WIK-Consult carried out this analysis²¹, which concluded that the potential for wholesale offerings in HFC networks is limited, even after upgrade from DOCSIS 3.0 to DOCSIS 3.1:

“Active virtual access products like direct amplifier access or frequency sharing and VULA are not practically feasible due to their complexity (direct amplifier access/frequency sharing, see section 2.1.3). This is because of the very limited capacity for only a few broadband access connections with an uncontended bandwidth

²¹ https://www.comreg.ie/media/dlm_uploads/2016/11/ComReg-1696b-1.pdf

character, especially in the upstream direction (VULA, see section 2.1.4). In addition, DOCSIS regularly does not support the Layer 2 (Ethernet) protocol typically associated with VULA because of its service-agnostic transmission behaviour, but operates with IP. A Layer 2 transmission standard exists alongside the DOCSIS standard, requiring DOCSIS as a prerequisite in CATV networks but not being part of it, namely BSoD. BSoD faces the bandwidth constraints of the downstream but even more of the upstream capacity (see section 2.1.4.2). In well-established CATV networks, there is no capacity left for VULA-like access services with dedicated and (in practice) uncontended bandwidth. A different option might be to have CATV network market entrant operators who still have to fill their network capacity and therefore intend to enter the wholesale market.

This situation will not change significantly when migrating to DOCSIS 3.1. First, the migration will be smooth and different DOCSIS releases will be operated in parallel in the same network. Secondly, the upstream capacity limitations exist here also, on a larger scale, but bandwidth demand will increase too. In addition, there is a trend towards more symmetrical services, something DOCSIS in general is not really well designed for (see sections 1.1, 2.1.4.4 and 2.3).

.....

Consequently, one can expect only a very limited number of CATV network operators to be interested in a wholesale business, namely those that have recently invested in passive and active network infrastructure, and that still have spare capacity which can be sold because their own customers cannot fill it in a reasonable time. These operators typically have regional coverage only, thus will not be present on a national market, and they would be restricted to bitstream services in Market 3b and Market 4, if at all. These operators have to consider, if their BSS/OSSs allow for wholesale business in a multi-tenant manner already or if upgrades would make such business non-viable.”

186. On this basis, ComReg has concluded that HFC networks are not part of Market 3a.

187. Nkom cannot see that there are any circumstances related to the Norwegian HFC networks that indicate other assessments and conclusions than those described in the Swedish, Danish and Irish market analyses for Market 3a. The analysis of HFC networks that WIK-Consult conducted for ComReg is also considered relevant for the assessment of HFC networks in Norway, and Nkom has chosen to attach importance to the conclusions of this analysis in its assessment of whether wholesale access to HFC networks should be included in Market 3a.

188. In view of this, Nkom has concluded that access to HFC networks is not part of Market 3a.

Fixed radio access networks

189. In the case of wholesale products for broadband access via fixed radio access networks, a wholesale customer can, in principle, offer retail products through access to the wholesale provider's sites or base stations for fixed radio access with the associated frequencies (local access). In a wireless network at a fixed location, the wireless connection is dedicated to a specific end-user, and the wholesale customer will therefore also be able to make use of each individual connection to the end users and determine the degree of utilisation (uncontended connection). At the same time, the wholesale customer in this kind of case will be able to differentiate the provision of services to the end-user (service independence).

190. However, there are other restrictions related to wholesale products that entail that the wholesale customer gets access to the wholesale provider's frequencies. These kinds of access products will require a form of subdivision of the frequency spectrum between the wholesale provider and the wholesale customers that want access to the wholesale provider's fixed radio access network. This kind of subdivision may result in capacity limitations and mean that the wholesale customers do not get control over the available capacity for the individual end user. Thus, the wholesale customers will not have the same flexibility in terms of being able to deliver their own retail services based on local access to a fixed radio access network, as opposed to local access to copper or fibre networks.

191. On this basis, Nkom finds that local access to fixed radio access networks does not provide sufficient control over the connection for fixed radio access networks to be considered part of Market 3a.

Conclusion

192. Against this backdrop, Nkom has found that there is no basis for including wholesale access to HFC networks and fixed radio access networks in Market 3a. This wholesale market thus comprises access to physical wholesale products in the copper and fibre networks and corresponding or comparable virtual wholesale products in the copper and fibre networks that fulfil the criteria for virtual wholesale products in Market 3a as specified in the Explanatory Note, i.e. 1) local access, 2) service independent, uncontended connection, and 3) access buyer has control over the connection.

2.4.3.2 Existing regulated products in former Market 4 encompassed by Market 3a

Operator Access

193. Telenor has a product called Operator Access that allows rental access to Telenor's copper access network. Operator Access enables the wholesale customer to offer services in the retail market without having to build up their own copper access network to the individual end user. This product is designed for providers that have their own equipment connected to Telenor's connection points and that want to rent one or more copper pairs from this point to an end-user address.

194. Operator Access can be used to realise various DSL-based services. Telenor offers various versions of this product that wholesale customers can use as a platform for their retail services. The interfaces for Operator Access are from the end customer's net termination point (NTP) to cross-connection from Telenor's block to the operator's block in the exchange or splitter. To order Operator Access, the operator customer must have entered into a co-location agreement for the Operator Access interface block.

195. Operator Access gives the wholesale customer full access or shared access to the access line between the subscriber and Telenor's connection point. Only the cable pair that terminates at the subscriber's premises can be used by the operator to provide shared access to the subscriber's access line. The delivery of shared access to the access line requires that Telenor or Telenor's resellers deliver PSTN or ISDN on the same cable pair. Figures 22 and 23 illustrate the responsibilities for the products Aksesslinje Full tilgang (full access) and Aksesslinje Delt tilgang (shared access). The thick black line indicates the access line or subloop line, and the grey line indicates telephony transmission on separate cable pairs. A more technically detailed description of the various Operator Access options can be found in Telenor's product portfolio for the operator market (www.telenorwholesale.no).

196. Operator Access provides physical access at the local level to the access line and is thus part of Market 3a.

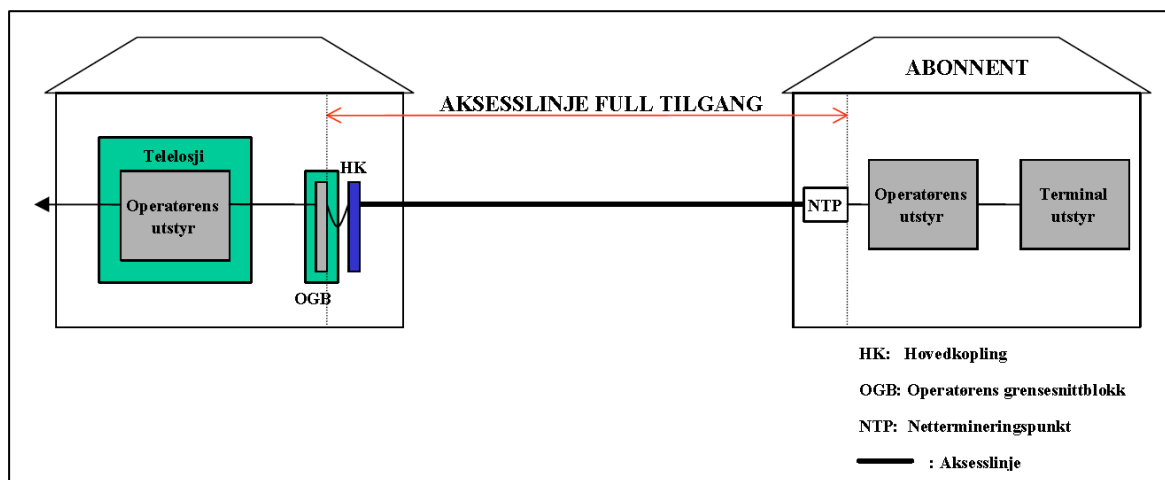

Figure 22: Telenor's responsibilities in the full access product variant "Aksesslinje Full tilgang".

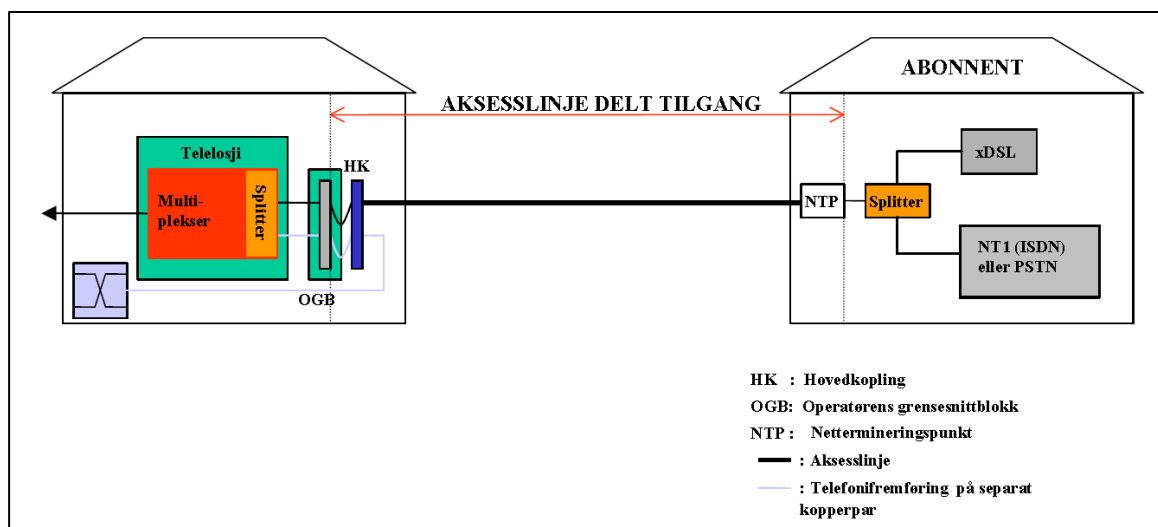

Figure 22: Telenor's responsibilities in the shared access product variant "Aksesslinje Delt tilgang".

LLU Fibre Access

197. Through Nkom's decision of 20 January 2014, Telenor was ordered to meet reasonable requests for local loop unbundling (LLU) access to fibre access lines. Against this background, Telenor offers the product LLU Fibre Access in a systematically developed point-to-point fibre access network. Telenor uses project deliveries for this product. Telenor informs wholesale customers about the relevant addresses where the product is available on request.

198. LLU Fibre Access provides physical access at the local level to the access line and is thus part of Market 3a.

2.4.3.3 Internal sales

199. In previous analyses of the former Markets 4 and 5, Nkom has included internal sales for Telenor and for vertically integrated providers as part of the relevant wholesale markets. The basis for market share assessments has also been based on market share figures for the retail market that are then adapted for the purpose, i.e. analysis of any significant market power in the relevant wholesale markets.

200. In connection with Nkom's decision in Markets 4 and 5 of 20 January 2014, ESA had comments regarding the inclusion of internal sales²². There ESA highlighted the function of market definition as a framework for assessing significant market power and, as applicable, imposition or withdrawal of specific obligations. ESA further expressed that it is necessary to demonstrate that effective direct or indirect disciplining mechanisms exist to justify the inclusion of internal sales.

201. Nkom concurs with ESA on the view that market definition constitutes a framework for the subsequent analysis of competition, be it in the form of a three-criteria test or an analysis

²² ESA's letter to Nkom dated 9 December 2013.

of significant market power. Moreover, Nkom believes that it is necessary that all circumstances that might serve to discipline the operators in a given market are taken into account in an assessment of whether there is significant market power. Nkom thus finds that it is necessary to assess whether competition from providers of broadband services in the retail market has a disciplining effect on the ability to exercise market power in the relevant wholesale markets.

202. Nkom sees grounds to maintain that internal sales should be included in the relevant wholesale markets. Nkom points out that if it is assumed that the relevant wholesale markets only include the external sale of wholesale products, there will be a risk of underestimation of the competitive significance of vertically integrated operators' offerings in the retail market. Nkom therefore holds that it is a correct starting point for the delimitation of the relevant market to include internal sales. In addition, Nkom holds that in connection with the assessment of significant market power it is necessary to assess the extent to which competition from vertically integrated providers' offerings in the retail market has a disciplining effect on the ability to exercise market power in the relevant wholesale markets.

203. Consequently, Nkom has assumed that internal sales are part of the relevant wholesale markets. Furthermore, in connection with the assessment of market shares, Nkom has undertaken supplementary assessments of market shares based on external sales.

2.4.4 Assessment of Market 3b Wholesale Central Access criteria for each technology platform

204. Market 3b is based on former Market 5 and comprises access products with regional or national connection points, as well as products with local connection points that do not fulfil the other two requirements for virtual wholesale products in Market 3a, cf. Section 2.4.3. It is stated in the Explanatory Note (page 46) that the Commission believes that copper and fibre-based bitstream products are substitutable and that both ought therefore to be included in the market for wholesale central access:

“Compared to WLA access products, WCA access products are typically provided to the access seekers at a higher and more central layer in the network architecture, and can be used to provide best-effort retail services to both residential and non-residential customers. It remains likely that there is a chain of substitution between copper DSL-based bitstream services and fibre-based bitstream services provided over FTTH and FTTC/VDSL networks in the near- to medium-term future.”

205. The wholesale products included in Market 3b are characterised by the fact that they are used to offer access products for mass market needs and that access usually takes place at a regional or national level in the network. Thus, there is most often a greater distance from the connection point to the end user in Market 3b products than is the case for Market 3a products. This means that Market 3b products can be used by wholesale customers that want

to offer broadband access to the mass market without making significant investments in infrastructure and equipment.

206. Central access in the network also means that the wholesale customers in Market 3b lose some of the flexibility that characterises Market 3a access. Wholesale customers in Market 3b do not use their own transmission equipment and in principle are only able to offer standardised retail services based on the wholesale provider's access services. Central access thus provides the wholesale customer with limited control over the connection to the end user and limited ability to differentiate the retail product.

2.4.4.1 Definition and delimitation of Market 3b

207. In connection with the delimitation of Market 3a, Nkom has made an assessment of whether or not virtual access at the central level to a copper network, fibre network, HFC network and fixed radio access network is part of the market.

Copper and fibre networks

208. Virtual copper and fibre-based wholesale products included in Market 3a must meet the criteria 1) local access, 2) service independent, uncontended connection, and 3) access buyer has control over the connection. Wholesale products included in Market 3b are not subject to such stringent requirements, and the access point will normally be more central than in Market 3a, i.e. at the regional or central level of the network.

209. Based on this, Nkom assumes that virtual wholesale products in copper and fibre networks that are offered at a regional or central level, and wholesale products offered at a local level, but does not fulfil the other requirements for products in Market 3a, and the products are used to provide access products for mass market needs, will be included in Market 3b.

HFC networks

210. In Section 2.4.3.1, Nkom has concluded that access to the HFC network on a wholesale level is not included in Market 3a. The reason is that neither physical access at local level, nor virtual wholesale access that fulfils the criteria to be a functional substitute for physical access, are considered to be technically or commercially realisable within the time horizon covered by this analysis.

211. In view of the fact that the connection level for a product in Market 3b can be at a more centralised level, and that there is no requirement for the connection to be "uncontended", and also that the access buyer's opportunity to differentiate the end-user products can be reduced as a consequence of limited control of the network, the starting point for assessing whether the HFC network is part of the relevant market will differ from what applies to Market 3a.

212. In the Explanatory Note (page 46), the Commission gives the following guide to the assessment of whether wholesale access to the HFC network should be included in Market 3b:

“In order to include a CATV-based wholesale access offer in the market NRAs should, therefore, analyse whether a potential entrant into the retail broadband market would switch to a CATV-based WCA product in case of a SSNIP test of the other WCA product. In this assessment, the configurations of the broadband services (e.g. QoS, multicasting), the potential coverage provided (i.e. given the limited footprint of CATV, broadband services may be handed over to ISP at national level only), as well as pricing are determinant.”

213. The HFC networks in the Norwegian market have relatively great prevalence and use the updated technical standard docsis 3.0²³. The docsis 3.0 standard facilitates that, in technical terms, wholesale services can be offered on a cost-effective basis.

214. Use of the docsis 3.0 standard entails that the wholesale access which can be offered in the HFC networks is equivalent to the access to the copper- or fibre-based access networks in terms of capacity and quality. For an access seeker who accepts that the wholesale product does not give full control of the connection and has a more limited opportunity to differentiate the end-user product in terms of quality parameters, speeds, etc., Nkom believes that wholesale access at a centralised level in the HFC network will be substitutable with wholesale access in copper- or fibre-based networks. This will be even more applicable to an operator that does not already offer copper- or fibre-based end-user products, and which therefore will not have costs associated with migration of production platforms.

215. On the basis of the aforementioned, it is Nkom's assessment that there is also a commercial basis to offer wholesale access in Market 3b to remote access buyers in HFC networks. The Nkom notes, however, that today no such access is offered. In view of the fact that the HFC networks are suitable to cover the demand for access in Market 3b and that options which cover this demand could be established without any need to make large investments, Nkom believes that the HFC networks constitute a potential competitive threat to access in copper- or fibre-based access networks. In Nkom's assessment, this threat provides a basis to include access to HFC networks in the relevant market. based on direct disciplining effects. On this basis, Nkom has not found it necessary to assess whether access to HFC networks could also be included on the basis of indirect disciplining effects from competition in the end-user market.

216. Nkom thus concludes that access to HFC networks shall be included in Market 3b.

Fixed radio access networks

²³ Get has announced that they will update with docsis 3.1 during the autumn of 2018: <https://itavisen.no/2018/06/29/her-laster-get-ned-med-spinnville-hastigheter-og-det-kan-du-smart-ogsa/>

217. In Section 2.4.3.1, Nkom has discussed whether wholesale access to fixed radio access networks is part of Market 3a. There Nkom concluded that this was not the case, since this kind of access does not provide sufficient control over the connection. When the access level is moved from the local to the central level, and it is no longer assumed that the wholesale customer has control of the connection, the starting point for the assessment of whether fixed radio access networks ought to be included in Market 3b is different than for the corresponding assessment in Market 3a.

218. Technically, wholesale central access is also possible in fixed radio access networks; however, fixed radio access networks are considerably less prevalent than HFC networks. Fixed radio access networks must therefore be assumed to have significantly less potential for direct competition pressure than HFC networks. To some extent, there may be indirect disciplining effects that argue in favour of including regular radio access networks in Market 3b. Nkom finds that there are grounds to include fixed radio access in Market 3b.

Conclusion

219. Against this backdrop, Nkom has concluded that wholesale access at a regional or central level, and wholesale access offered at a local level, but does not fulfil the other requirements for products in Market 3a, via copper networks, fibre networks, HFC networks and fixed radio access networks shall be included in Market 3b.

2.4.4.2 Existing regulated products in former Market 5 encompassed by Market 3b

220. Telenor's provision in the market for wholesale central access consists of products aimed at national, regional and local broadband providers that want to offer standardised broadband products without having to make major investments in their own equipment. These products are also used as a supplement to Operator Access in areas where wholesale customers that would otherwise purchase Operator Access do not find it commercially viable to invest in their own equipment. Of the wholesale products Telenor currently offers, it is natural to place DSL Broadband Access and VULA Fibre in Market 3b, as these products do not meet all requirements discussed in Section 2.4.3 for virtual access in Market 3a. This applies in particular to the requirements that the wholesale customer has control of the connection and that the connection is uncontended.

DSL Broadband Access

221. DSL Broadband Access enables customers to provide internet connectivity via Telenor's copper access network. The products ADSL (Basis, Premium and Proff²⁴), VDSL (Basis, Premium and Proff) and SHDSL (Premium and Proff) enable use of Telenor's copper access network to connect end customers to the internet. The products are offered with fixed or rate-adaptive speeds and a variety of classes in order to allow different end-user needs to

²⁴ See Section 2.4.6 for a dedicated assessment of Telenor's Proff products.

be accommodated. To route traffic from the access network to the operators and on out to the internet, Telenor offers the product E-line.

222. Jara ADSL (Basis, Premium and Proff) are wholesale products that come with several speed classes and asymmetric upload and download speeds. Jara ADSL is defined between the subscriber's interface and the interface for broadband access points (BAP) and provides broadband connection to various types of service networks or broadband applications offered by the wholesale customer, cf. figure 24. The wholesale customer has a non-exclusive right to offer services on the ADSL access from the BAP to the ADSL modem. The service is supplied with a standardised interface for connecting end-user equipment.

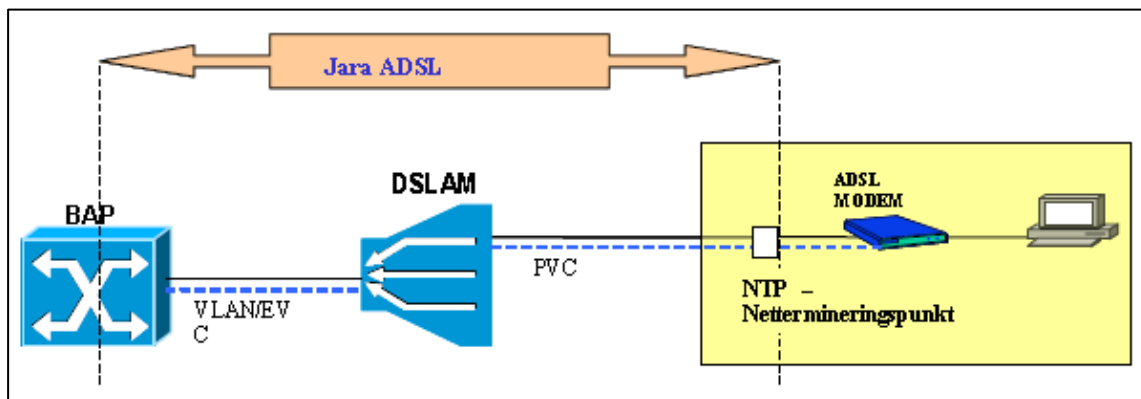

Figure 23: Reference figure Jara ADSL.

223. Jara VDSL (Basis, Premium and Proff) are wholesale products that offer higher capacity than Jara ADSL. The wholesale products come with several different speed classes and asymmetric upload and download speeds. Jara VDSL is defined between the subscriber's interface and the BAP interface and provides broadband connection to various types of service networks or broadband applications offered by the wholesale customer, cf. figure 25. The wholesale customer has a non-exclusive right to offer services on the VDSL access from the BAP to the VDSL modem. The service is supplied with a standardised interface for connecting end-user equipment.

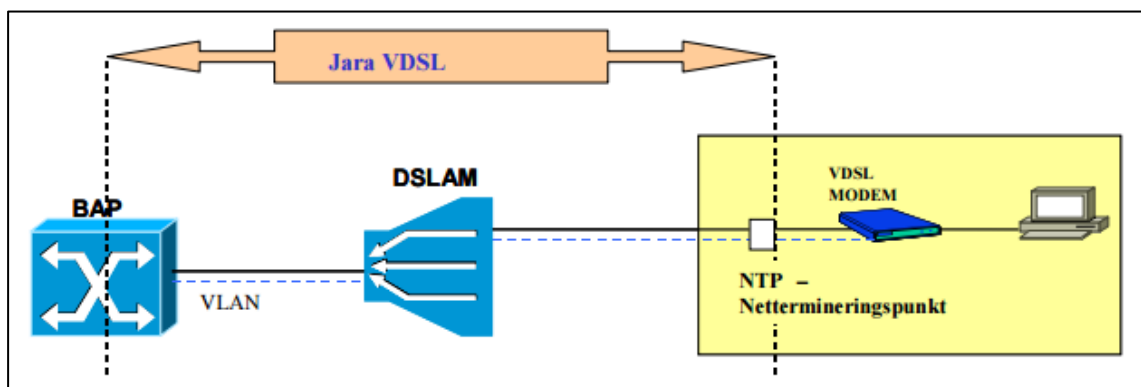

Figure 24: Reference figure Jara VDSL.

224. Jara SHDSL (Premium and Proff) are wholesale products aimed at the business segment. The wholesale products come with several different speed classes and symmetrical upload and download speeds. Jara SHDSL is defined between the end user's interface and the BAP interface and provides broadband connection to various types of service networks or broadband applications offered by the wholesale customer, cf. figure 26. The wholesale customer has a non-exclusive right to offer services on the SHDSL access from the BAP to the SHDSL modem. The service is supplied with a standardised interface for connecting end-user equipment.

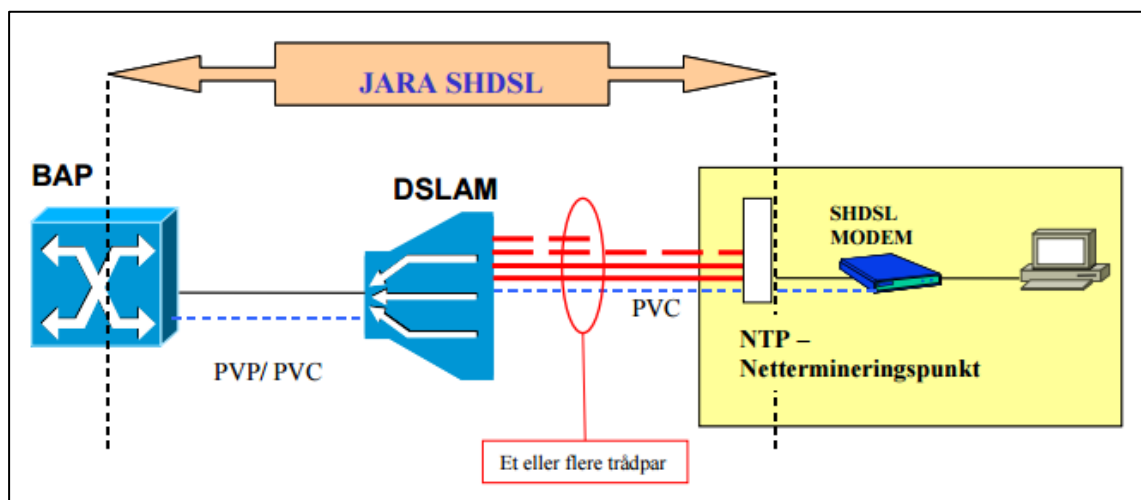

Figure 25: Reference figure Jara SHDSL.

225. There is a more technical description of these wholesale products in Telenor's product portfolio for DSL Broadband Access (www.telenorwholesale.no).

VULA Fibre

226. VULA Fibre (Basis and Proff) enables customers to provide internet connectivity via Telenor's fibre-based GPON network. The wholesale products come with several different speed classes, symmetrical upload and download speeds, and support for Multicast (the Basis product).

227. VULA Fibre is defined between the subscriber's ONT (optical network termination) interface and the interface to the wholesale customer's ODP (Operator Delivery Port) and provides broadband connection to various types of service networks or broadband applications offered by the wholesale customer, cf. figure 27. The wholesale customer has a non-exclusive right to offer services on the VULA access from the ODP to the ONT. The service is supplied with a standardised interface for connecting end-user equipment. VULA Fibre is aggregated through Telenor's access network and delivered to the wholesale customer in dedicated ODPs, while the accesses are transmitted as virtual local area networks (VLAN).

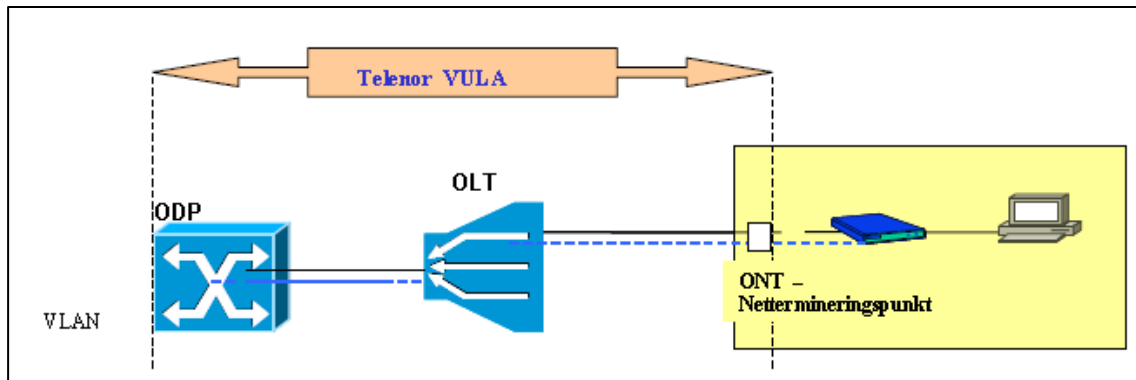

Figure 26: Reference figure Telenor VULA.

228. There is a more technical description of these wholesale products in Telenor's product portfolio for VULA (www.telenorwholesale.no).

2.4.4.3 Internal sales

229. In Market 3b too, any sale of broadband access products in the retail market, irrespective of the underlying access technology, is matched by an external or internal sale, or use, of broadband access at the wholesale level.

230. In Nkom's assessment, defining relevant product markets at the wholesale level cannot only take into account existing products in the wholesale market. To be able to assess the real competitive effect at the wholesale level of vertically integrated companies' own use of wholesale inputs in the production of retail services, it must be assessed whether internal sales, or internal use, of broadband access products supplied through various access technologies and on various interfaces should also be included in the relevant wholesale market. Operators that base their production of broadband access services for the retail market on the purchase of LLU or other wholesale products at the local level ought in principle to be equated with vertically integrated access network owners.

231. In Nkom's opinion, the same arguments that applied in Market 3a also apply in Market 3b in terms of whether internal sales should be included in the relevant market. Nkom therefore refers to this assessment for Market 3a, cf. Section 2.4.3.3.

232. On this basis, Nkom finds that internal sales or use of access lines, be they based on own access network or wholesale purchase in Market 3a, for the provision of broadband access services in the retail market shall be included in the wholesale market for central access at a fixed location.

2.4.5 Assessment of the need for delimitation of sub-markets within Markets 3a and 3b based on capacity or technology

2.4.5.1 Technological platform as a potential delimitation basis

233. An access buyer makes a technology choice, which enables him to offer a range of broadband services, including with varying capacities. While the choice of technical platform for the offer might constrain the selection of services provided within a geographical area, the switching cost both to the service provider and to the end customer would usually be marginal for different products deliverable on that platform. Hence, a small but significant increase on the wholesale price of one specific product is likely to lead to the wholesale customer offering the affected retail customers a “neighbour” product in terms of capacity. From the Jara ADSL price list of Telenor, it can be observed that in case of a 5% or 10% increase in the price of one specific product, there will generally be an alternative product with a higher capacity available, at the same or lower price than the new price of the product currently provided. A potential demarcation point in the delimitation of the wholesale markets could therefore be between the capacities/products that can be offered by access buyers on the copper platform, compared to capacities/products that can be offered by access buyers on a fibre-based or HFC platform. It is noted that substitution analyses within the wholesale broadband markets in EEA generally seem to be based on substitutability between different platforms rather than between individual wholesale products on the same platform.

2.4.5.2 The end-user markets are the starting point for the analysis of the wholesale markets

234. Since the end-user market for standardised broadband access constitutes one single market irrespective of capacity, Nkom believes that a natural starting point would be a technology neutral market also when assessing the delimitation of the derived wholesale markets. In the same way a retail customer procures a broadband service to be able to access the internet with associated services, a wholesale access customer acquires access in Market 3a and/or Market 3b to be able to provide access to the internet with associated services to their retail customers.

235. In this respect, Nkom refers to the Explanatory Note where the Commission states:

“As regards market definition, NRAs’ analyses so far have not shown significant breaks in the chain of substitution when comparing current copper-based broadband services to those provided over optical fibre. Therefore, fibre-based access products (FTTN/VDSL and FTTH/B) are included in the physical local loop and sub-loop unbundling or in the WBA markets in view of the increasing availability of fibre networks and the prospective deployment plans of operators.”

2.4.5.3 Further substitution assessments in Markets 3a and 3b across technology platforms

236. In line with the approach taken by most other national regulators in the EEA, Nkom has chosen to assess the substitutability between the different technology platforms within each of those wholesale markets in a qualitative rather than in a quantitative manner.

237. Wholesale products based on copper and fibre within Market 3a as well as products based on copper, fibre and HFC within Market 3b have technical and functional characteristics sufficiently similar to belong to one single product market²⁵.

238. Nkom has not been able to identify any specific end user application where an fibre or HFC based platform is indispensable to provide the internet access service²⁶. This also supports that there is a substitution across the different technology platforms within each of Markets 3a and 3b.

239. In the light of the market development with growing demand for higher-capacity services, it is likely that the substitution between access to platforms offering lower and higher capacities will not be symmetrical. At a price increase of 5-10% for copper-based access, more access buyers will choose to switch to fibre-based access products than what would be the case in the opposite situation. However, as long as fibre-based access, in areas where it is available, is seen as a substitute to copper-based access, wholesale products on the two technology platforms will be in the same product market if copper-based access is the focal product.

240. In the following section, Nkom explains the selection of copper-based access as the focal product.

2.4.5.4 Identification of focal product in case of asymmetric substitution

241. In the case where a substitution is not symmetrical, even a one-way substitution from a “focal product” A to another product B could be sufficient for product B to be in the same market as product A. BEREC discusses this issue in the “BEREC Report on impact of fixed-mobile substitution in market definition”.²⁷ Even though the report primarily concerns substitution between fixed and mobile services, it also discusses a number of general factors pertaining to substitution assessments. As the report shows, in a situation with asymmetrical substitution the starting point is “*the main product under investigation*”. The report also refers to how an alternative might be to choose the product for which there are deemed to be competition problems - or the product for which potential or actual competition problems are considered to be the greatest. Nkom has used this approach.

²⁵ Comreg specifically notes that this assessment stands irrespectively of an observed decline in demand for “Current Generation” wholesale access services.

²⁶ This fact has been considered by the German NRA and seems to support the definition of one single product market, irrespectively of capacity provided.

²⁷ BEREC report BoR (12) 52.

242. Nkom believes that the competition problems are more severe related to wholesale access to the current generation copper platform than related to NGA networks based on fibre or HFC networks. Nkom points out that the assessment below of the severity of competition problems between the different technology platforms only aims to serve as a background to select the focal product, and does not serve as a final product market delimitation.

243. In Nkom's view, the main reasons for selecting copper based broadband access products as the focal product in the substitution assessment in Market 3a as well as in Market 3b are:

- a. The scope of the infrastructure expansion to provide broadband at higher speeds is still considerable. The expansion results in a competitive pressure to win end-users that do not have access to the infrastructure for the delivery of such services. Since most market players operate with uniform retail prices at national level, this competition pressure has an impact on the pricing towards end-users that already have access to such infrastructure as well as on pricing of wholesale access based on existing fibre infrastructure. No equivalent competitive pressure from various alternative operators applies to copper-based infrastructure.
- b. A significant number of households have DSL-based broadband as the only available platform for broadband offers. If a significant price increase is observed for copper-based wholesale products used to serve such a customer, the wholesale access buyer, if he wants to keep his profitability stable, does not have any other options than either to pass the price increase on to the retail customer or to construct his own access network. On the other hand, practically all households with broadband based on HFC or fibre have at least one alternative infrastructure for fixed broadband, either in the form of the copper network or, in some cases, also other HFC or fibre networks. For buyers of wholesale access providing a retail broadband service based on fibre, in case of a significant price increase for the wholesale product currently used in providing the service, it will still in some cases be possible to provide a service with a capacity similar to the one currently provided based on wholesale products on the copper platform instead. For service delivery to other end-users, the opportunity for a copper-based broadband wholesale access offer will represent a broadband connection offer albeit not necessarily providing the opportunity for similar capacity.
- c. Access to copper-based broadband appears to be the only alternative to achieve an approximate nationwide offer of broadband services in the end-user market, in line with Telenor's offer. An alternative provider can establish fibre-based broadband offers by competing for new development or by negotiating access to one or more fibre operators with various coverage areas. The transaction costs of ensuring access to a large part of the fibre connections will, however, be significant, nor is the establishment of own fibre an alternative in order to establish an approximate nationwide offer. Some

NRAs²⁸ have relied upon the coverage of the regulated operator's network, consisting of both copper-based and fibre-based accesses, to define the combination of fibre and copper based accesses as one single focal product, before using this focal product to assess substitutability with other technologies such as HFC.

2.4.5.5 Practice from other EEA countries and the Commission

244. Generally, other NRAs in the EEA have concluded that there is no basis to delimit wholesale access to fixed networks to provide broadband services neither based upon technology nor based upon capacity. However, there are a few examples where NRAs have had other assessments of this issue. Below, Nkom discusses a notification from Lithuania in 2010 and a public consultation in Sweden in 2018.

245. In its decision in case LT/2010/1035, the Commission referred to that the regulator in Lithuania had partially carried out a hypothetical monopolist test. The test results indicated that the substitution between unbundled access to copper and fibre networks was insufficient to incorporate them in the same market. The Commission pointed out that a conclusion deviating from the practice in other member states through defining two product markets on the basis of technology, would require substantiation beyond a hypothetical monopolist test.²⁹ The Commission rejected the argument that the possibility for access buyers to provide retail services with a higher quality and enhanced services like high definition TV content, through wholesale access to fibre-based networks, should provide a basis for the definition of two separate relevant product markets. The Commission pointed out that the regulator had overlooked the fact that broadband access over fibre also is a substitute for the bandwidths being offered in a copper network. It should also be noted that in 2010, fibre-based connections exceeded the number of DSL-based connections in Lithuania.

246. In a draft decision from PTS in Sweden, which has undergone a public consultation in the Summer of 2018, PTS has proposed to define two distinct wholesale product markets within Market 3a, with one product market consisting of physical and virtual access to fibre-based access networks.³⁰ It should be noted that the main factor which led to this conclusion, is that separate retail markets have been defined, cf. section 2.5.5.1 in draft decision from PTS. In section 2.3.2.5 above, Nkom has found that the key factors that PTS's preliminary conclusion is based on, do not apply in the same way in the Norwegian retail market. As only one single retail product market for standardised broadband access has been identified in

²⁸ E.g. Ofcom and RTR, the latter without explicitly referring to a "focal product".

²⁹ [https://circabc.europa.eu/sd/a/1b769935-925f-4fe8-b5e2-4da7170c2d61/LT-2010-1035%20Acte\(2\)_EN-Opening%20Phase%20II%20nr%20et%20date.pdf](https://circabc.europa.eu/sd/a/1b769935-925f-4fe8-b5e2-4da7170c2d61/LT-2010-1035%20Acte(2)_EN-Opening%20Phase%20II%20nr%20et%20date.pdf) RRT bases its conclusion of the lack of demand and supply side substitutability between FTTH and copper based products on the answers provided by respondents to a questionnaire where a "hypothetical monopolist test" was devised. No further studies were apparently conducted by RRT. Especially in view of the market definitions adopted by many other European NRAs, which include both copper and fibre networks into the same relevant product market, such further arguments would be necessary to justify that it is appropriate to define two specific product markets in Lithuania.

³⁰ https://www.pts.se/globalassets/startpage/dokument/icke-legala-dokument/remisser/2018/telefoni--internet/3ao3b/utkast-till-beslut_3afiber_180618.pdf

Norway, there is no similar basis to identify several wholesale markets within Market 3a or Market 3b in the Norwegian market. Nkom would also like to point out that PTS has not yet notified its draft decision to the Commission.

2.4.5.6 Conclusion

247. On this basis, Nkom concludes that all relevant access technologies for fixed broadband connection, cf. Sections 2.4.3 and 2.4.4, are included in one single product market within Market 3a and one single product market within Market 3b.

2.4.6 Delimitation of the markets for wholesale central and local access against the wholesale market for high-quality access products

248. In the previous analysis of the wholesale markets for LLU and Broadband Access (former Markets 4 and 5), Nkom concluded that the wholesale provision of broadband access products delivered via all fixed access networks should be included, but that the wholesale market for leased lines products (former Market 6) is not part of the same relevant wholesale market.

249. In the Explanatory Note, the Commission has defined one retail market for standard access products and another retail market for high-quality access products. The description of different customer segments in the Norwegian retail market for fixed access in Section 2.2 above shows that in the Norwegian market it is natural to distinguish one product market for standard broadband subscriptions and another product market for access products requested by businesses in need of access solutions with greater functionality and/or quality than is provided by the standardised mass market products. Against this backdrop, Nkom concluded in Section 2.3.1 that there is not sufficient substitutability on either the supply side or the demand side for inclusion of standardised broadband access and high-quality access products in the same relevant retail market.

250. Against this backdrop, Nkom is basing its analysis on the ESA Recommendation, whereby the wholesale markets for standardised access products (Market 3a and Market 3b) and the wholesale market for high-quality access products (Market 4) will in principle be derived from two different retail markets.

251. The retail offering in the market for standardised broadband access can be based on Telenor's wholesale products in Market 3a/3b, wholesale products from other access network owners and/or own access networks. With regard to retail offerings in the market for high-quality access products, this will mainly be based on Telenor's wholesale products in Market 4 (leased lines, optical channel, etc.), that are equivalent to wholesale products from other access network owners and/or own access infrastructure. However, it is also possible to use wholesale products in Market 3a/3b as part of the retail offering in the market for high-quality access products, if the customer's needs for an access solution can be partially met by use of Market 3a/3b products. This applies in cases, for example, where a company wants an access

solution with quality and/or functionality beyond that afforded by standardised broadband access that can connect multiple locations, but where the quality and/or functionality that can be offered based on a Market 3a/3b product is sufficient for one or more (but not all) of these locations.

252. This means that a retail offering in the market for high-quality access products may partly be based on wholesale products in Markets 3a & 3b if the customer's requirements are such that the quality and/or functionality provided by standardised broadband access is sufficient for some of the customer's locations. Moreover, the delimitation between Market 4 and Markets 3a & 3b does not entail any limits in terms of how advanced retail services offered based on Market 3a/3b products can be. Access buyers in Market 3a/3b can offer the retail services they want based on Market 3a/3b products.

253. It follows from Nkom's market analysis of Market 4 that wholesale products included in Market 4 are characterised by certain product properties related to quality, availability and service level. Wholesale products in Market 3a/3b do not meet the product property requirements that apply to Market 4 products. As this is a central part of the definition and delimitation of Market 4, these product properties comprise the main distinction between Market 3a/3b products and Market 4 products, making it an important starting point when determining whether a specific wholesale product belongs to Market 3a/3b, Market 4 or another wholesale market.

254. Another difference between Markets 3a & 3b and Market 4 is that Market 3a/3b products provide the wholesale customer with access to an access network from a connection point that allows the wholesale customer to establish rival retail offerings to all the broadband customers in a geographical area that are connected to the relevant access network, whereas Market 4 products consist of individual access connections that the wholesale customer purchases to provide an access product or access solution to a specific end customer that requires quality and functionality beyond that afforded by standard broadband subscriptions.

255. Telenor has three different product profiles for DSL Broadband Access: Basis, Premium and Proff. Proff differs from the other two profiles in that the Proff products enable a certain degree of traffic prioritisation. In all other respects, however, there are no significant differences in features between the three product profiles. Similarly, Telenor has two product profiles for its fibre-based VULA product, Basis and Proff. The possibility to prioritise traffic means that the Proff products are primarily assumed to be used as an input in retail deliveries to business customers.

256. Although the Proff products enable a certain amount of traffic prioritisation, Nkom has concluded that this is not sufficient to be considered as meeting the requirements for quality beyond that provided by mass market products, which characterise Market 4 products. Furthermore, it is also not the case that Market 3b only contains wholesale products that are used exclusively as an input factor in the provision of broadband to residential customers. This

means that Nkom has reached the conclusion that it is most appropriate to continue to group all DSL Broadband Access products in the same relevant product market. The same also applies to the fibre product VULA Proff.

2.4.7 Delimitation of the markets for wholesale central and local access against individual fibre accesses outside systematically developed access networks

257. In the Ministry of Transport and Communications' appeal decision dated 18 December 2014, after processing appeals concerning Nkom's decisions of 20 January 2014 in the wholesale market for LLU (former Market 4) and the wholesale market for Broadband Access (former Market 5), the Ministry concluded that individual fibre accesses that are not part of a systematically developed access network were not covered by the access obligation in former Market 4. At the same time, the Ministry asked Nkom to clarify the content of the terms "systematically developed access network" and "individual fibre accesses". The Ministry also asked Nkom to assess whether individual fibre accesses ought to be included in future regulation of the broadband markets.

258. Against this backdrop, in a letter dated 7 September 2015, Nkom clarified the distinction between systematically developed access networks and individual fibre accesses that are not part of a systematically developed access network. It is apparent from this clarification that Nkom regarded areas that are developed on the basis of development analyses for defined geographical areas as systematic developments. These access networks have been systematically rolled out to a group of customers. The access obligation Nkom has imposed on Telenor's fibre LLU and fibre VULA access applies in these areas.

259. Individual fibre accesses will typically be rolled out on assignment from professional customers (in this context companies and organisations, including wholesale customers). In these kinds of cases, the customer contacts Telenor to order an individual fibre access.

260. It is also apparent from Nkom's clarification that if Telenor, on the basis of several individual orders or requests in the same area, decides to systematically roll out a network that covers multiple accesses, this will be regarded as a systematically developed network. Further roll-out of fibre accesses in an area, entailing that individual fibre accesses can no longer be regarded as individual, will cause the status of such accesses to be changed to systematically developed fibre access networks. One or more individual orders / requests that result in the extension of an existing systematically developed access network will be regarded as part of this access network.

261. In Nkom's view, no new arguments have emerged since September 2015 to indicate that there are grounds to amend Nkom's clarification of the difference between systematically developed access networks and individual fibre accesses that are not part of a systematically developed access network. Nkom is therefore basing the current analysis on the same interpretation of these terms as before.

262. Nkom's decision and the Ministry of Transport and Communications' appeal decision from 2014 did not explicitly state whether the individual fibre accesses were part of former Market 4 and/or Market 5. Nkom's and the Ministry of Transport and Communications' assessments focused exclusively on whether these kinds of fibre accesses were subject to an obligation to grant access. At the same time, the definitions of the respective retail markets that Market 3a & 3b and Market 4 are derived from differ somewhat from the definition of the retail market on the basis of which the former Markets 4 and 5 were derived. Nkom therefore finds it appropriate to assess whether individual fibre accesses are included in Market 3a and/or Market 3b.

263. Nkom cannot see that the Commission, in connection with the definition and delimitation of Market 3a, has expressed that individual fibre accesses that are not part of a systematically rolled out access network are part of this wholesale market. By contrast, it is stated in the Explanatory Note (page 42) that it is FTTH, FTTB or FTTC/VDSL networks, i.e. non-individual fibre accesses, that the Commission believes ought to be considered as functionally equivalent to traditional copper-based LLU, and thus be included in Market 3a:

"Therefore, access to a FTTH, FTTB or FTTC/VDSL (either point-to-point or point-to-multipoint) network (our underlining) should be considered as functionally equivalent to traditional copper LLU."

264. Furthermore, the Commission notes that it is access products that are available in a "fibre to the home" (FTTH) architecture or in "fibre to the curb" (FTTC) / VDSL scenarios that should be included in Market 3a/b:

"In this respect, NRAs should include in the WLA market all access products available at the physical layer in a point-to-point FTTH architecture, in a point-to-multipoint FTTH architecture or in FTTC/VDSL scenarios (e.g. ODF unbundling access, cabinet unbundling access, access to the terminating segments at the concentration/distribution points)."

265. Nkom holds that individual fibre accesses cannot be regarded as part of an FTTH architecture or FTTC / VDSL scenario. Individual fibre accesses are usually used as an input in deliveries to business customers with special capacity and/or quality requirements, and not as an input in fibre provision based on an FTTH architecture or FTTC / VDSL scenario. Based on a substitutability assessment, individual fibre accesses cannot therefore be regarded as a satisfactory substitute for LLU or other types of access in a systematically developed access network for a wholesale customer that wants to compete with the access network owner for a group of customers in a given geographical area in the retail market for standardised broadband access.

266. In Nkom's view, individual fibre accesses will primarily be established for use as a basis for services in the retail market for high-quality access products, e.g. VPN services and high-quality, dedicated access to the internet, or to be offered as dark fibre. It is normally relatively

expensive to develop an individual fibre access, implying that the access would have to be used to provide products other than standardised broadband access. Nkom has also received information from Telenor confirming this type of use of the company's individual fibre accesses.

267. On this basis, Nkom has concluded that individual fibre accesses that are not part of a systematically-developed access network are not part of Market 3a or Market 3b.

2.5 Definition of the relevant geographical markets

268. Nkom delimited the relevant product market for standardised broadband access at the retail level in Section 2.3 and the derived relevant product markets at the wholesale level (Market 3a and Market 3b) in Section 2.4. In this section, Nkom will delimit the product markets geographically.

2.5.1 General

269. In the previous market analysis of the wholesale markets for LLU and broadband access of 20 January 2014, Nkom concluded that the geographical markets are national.

270. In accordance with paragraph 57 of the Guidelines, the geographical market may be defined as that area in which the relevant product is offered on approximately similar and sufficiently homogeneous conditions of competition. The degree of substitutability on both the supply and the demand side may be taken into consideration in the assessment of the geographical market and, as a part of such a substitutability assessment on the demand side, preferences and geographical purchase patterns should be taken into account. However, paragraph 60 of the Guidelines points out that geographical markets in electronic communications have traditionally been defined by reference to the area covered by the relevant network the effective boundaries (jurisdiction) of the legal regulation of the market.

271. In the further discussion of Norway as the area of jurisdiction, Norway means mainland Norway, cf. the definition of the geographic scope of the Electronic Communications Act in Section 2.1.2.

272. It may be natural to further divide some product markets into subnational geographical markets, since there are local providers of electronic communication services encompassed by the relevant product market. ERG published its "Common Position on Geographic Aspects of Market Analysis (definition and remedies)" (ERG Common Position) in October 2008, in which ERG recommends a step-by-step process for geographical definition of the market. The first step in this process is to identify whether it is necessary to undertake a detailed geographical analysis.

273. In June 2014, BEREC published "Common position on geographical aspects of market analysis" (BEREC Common Position). This document is based on the same main principles as

the ERG Common Position, but also takes into account developments from 2008 to 2014 that are relevant in an assessment of definitions of geographical markets, including the roll-out of new NGA networks and upgrades to existing broadband networks.

274. The BEREC Common Position recommends that the geographical analysis be preceded by an assessment of developments in competition in the retail market. BEREC has identified the following indicators as the most relevant when national authorities are determining whether it is necessary to conduct a complete geographical analysis in order to assess whether it is appropriate to define local markets:

- Geographical differences in providers' networks and coverage
- Number of providers in the retail market, and their market shares, in different geographical areas
- Geographical differences in prices and product offerings

275. In accordance with BEREC Common Position, the choice of any geographical units that are going to be used as the basis for definition of a different geographical market than the national market ought to meet the following four criteria:

1. The geographical units must be mutually exclusive.
2. It must be possible to map the network structure of all relevant network providers and their service offerings within the geographical units.
3. There must be clear and stable boundaries between the geographical units.
4. The geographical units must be small enough that the competitive conditions will not vary significantly within the unit, but at the same time large enough that the burden on the providers and the authorities with regard to data collection and analysis is reasonable.

276. Based on BEREC's Common Position, Nkom has chosen a methodical approach to this analysis of definition of the geographical market in which we first assess the developments in competition in the retail market for standardised broadband access, and then use relevant indicators as defined by BEREC to analyse the level of homogeneity in the competitive conditions in different geographical areas.

2.5.2 Developments in competition in the Norwegian retail market for standardised broadband access

277. As mentioned in the BEREC Common Position, the geographical analysis should be based on the competitive situation in the retail market, since the main objective of imposing any ex-ante obligations at the wholesale level is to ensure the development of sustainable competition in the retail markets to the benefit of the consumers.

278. In the BEREC Common Position, it is pointed out that there will normally be two main types of competitive situations (paragraph 80 on page 20):

“These technical aspects will normally be considered by NRAs, in two main types of competitive situations. On the one hand, there are some Member States where wholesale remedies, particularly LLU, represent an important source of competition that, in some cases, is complemented by the presence, in certain areas, of an alternative network, normally cable. On the other hand, in other Member States, LLU is not so extensive, but there is an important source of competition derived from the presence of alternative infrastructures.”

279. Further, the BEREC Common Position provides the following description of the two competitive situations (paragraph 83 on page 21):

“Situation 1: Retail competition mainly driven by wholesale access to copper network and alternative infrastructures. This situation covers those Member States where competition in the retail market results simultaneously from the use of LLU, WBA, resale (or other wholesale services until now usually related to copper networks) and the deployment of alternative networks (e.g. cable, FTTx) by (alternative) operators.

Situation 2: Retail conditions mainly driven by inter-platform competition. This situation covers the dynamics of some Member States, where inter-platform competition is the main driver of retail competition. This is normally the case when the penetration of alternative infrastructures is high. These infrastructures will be based on technologies such as cable, mobile, fibre to the x (FTTx) or WI-FI, according to the precedents in Article 7 procedures. In this context, NRAs should effectively demonstrate that these technologies are capable of delivering the same features as copper-based services. This analysis will be part of the product market definition and is, therefore, outside the scope of this document.”

280. The Norwegian retail market for standardised broadband access cannot easily be categorised into one of these two competition situations. In the Norwegian broadband market, competition has elements of both types of competition described by BEREC and in this respect differs from the situation in many European countries, where the competitive conditions can be more easily described as either situation 1 or situation 2.

281. Nor is there a distinct boundary between geographical areas where the competition is based primarily on either access to Telenor’s networks or infrastructure competition. The wholesale regulation of LLU and Broadband Access is not geographically delimited, and the buyers of these wholesale products make use of access to Telenor’s networks all over Norway. Similarly, the development of fibre access networks is not limited to specific geographical areas in Norway. While fibre coverage is not the same in all areas, nor is it the case that developers of fibre access networks have concentrated on certain parts of the

country. This is described and discussed in more detail in the section below on geographical differences in different providers' networks and coverage.

282. In recent years, the development in competition in the Norwegian broadband market has thus been characterised by both access competition based on the wholesale regulation of Telenor's networks and infrastructure competition between Telenor and other fibre and HFC operators that have established their own access networks. This has paved the way for ever stronger competition in the Norwegian retail market for standardised broadband access.

283. Regulation of wholesale access to Telenor's networks was essential to create competition in this market. At the same time, regulation does not seem to have prevented a number of fibre network developers from establishing new broadband access networks in competition with Telenor's infrastructure. In addition, HFC networks constitute an important competitive factor in the broadband market. Technological developments have led to upgrades of both the copper-based and the HFC networks, meaning that much higher broadband capacities can now be offered via these networks than was the case a few years ago. This has resulted in increased competition also for customers requesting high-capacity broadband access.

284. Although mobile broadband is still not regarded as being in the same relevant product market as fixed broadband access (cf. the assessment in Section 2.3.3), it is assumed that the potential competition from 4G / LTE will be an increasingly clear competitive factor in the retail market for fixed broadband access in the coming years.

285. Figure 28 shows that broadband access via the copper network, HFC networks and fibre networks represents the vast majority of the overall retail market for standardised broadband access in the residential market. Competition in this market has evolved from strong xDSL dominance ten years ago to a situation where the three access technologies now have roughly equal market shares. Fibre-based broadband access is growing, largely at the expense of DSL-based broadband.

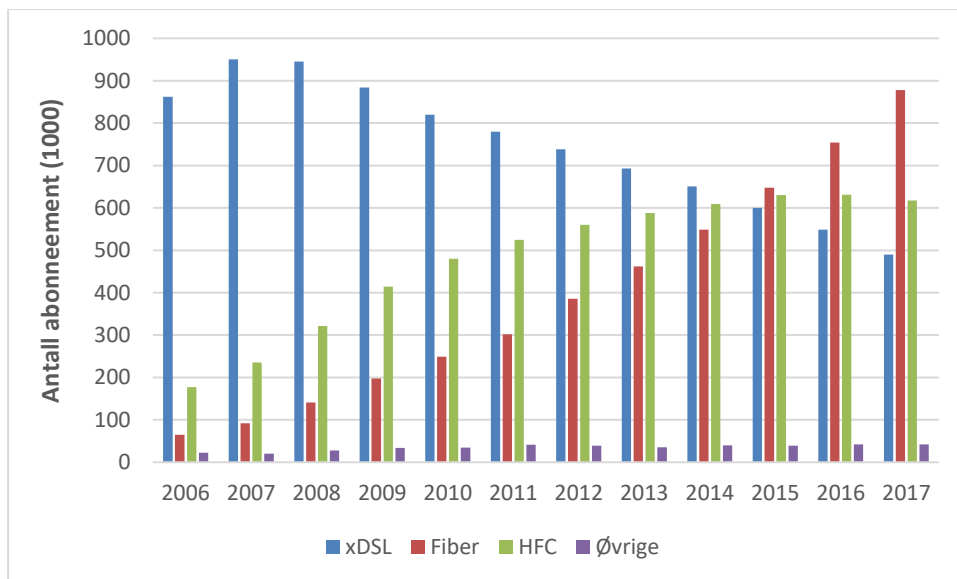

Figure 27: Number of fixed broadband subscriptions in the residential market. (Source: Nkom's electronic communications statistics for 2017)

286. In the BEREC Common Position (paragraphs 135-145), reference is made to the fact that the dynamics of competition in different national markets may differ as a result of different developments in respect of roll-out of NGA networks and upgrading of existing networks, and that this ought to be taken into account when national regulatory authorities consider delimitation of geographical markets.

287. Norway is a clear leader in terms of NGA roll-out. Figure 29 shows that Norway is among the countries with highest FTTH penetration in Europe. Moreover, in Norway fibre has largely been rolled out by operators other than Telenor. This means that the descriptions and assessments in the BEREC Common Position regarding roll-out of NGA networks in an early phase by the former monopolist cannot be used as the basis of an analysis of the Norwegian market without modification.

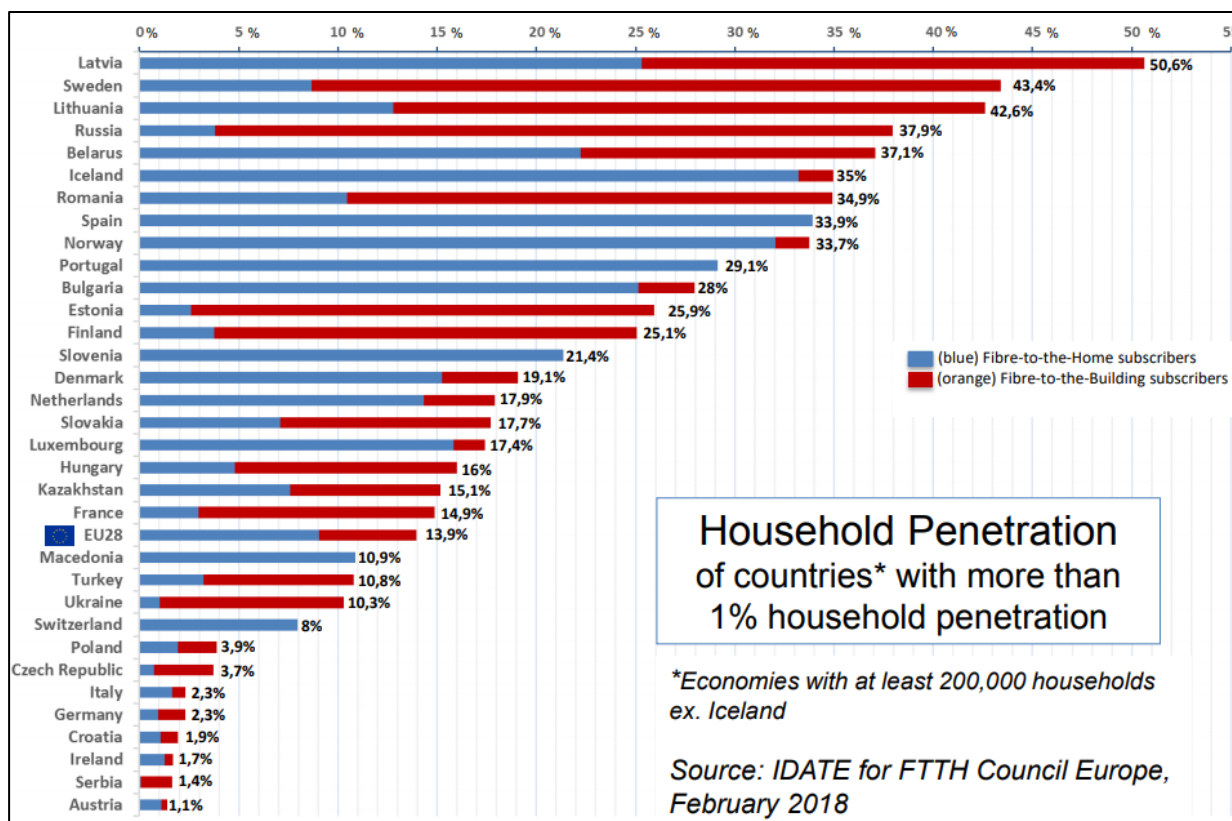

Figure 28: Fibre accesses in Europe. (Source: FTTH Council Europe)

288. The fact that Telenor has not previously led the way in the roll-out of fibre in Norway would seem to suggest that Telenor has stronger competitive incentives to upgrade its copper and HFC networks in the coming years than comparable suppliers with significant market power in other countries, which also have a strong position as a developer of fibre access. At the same time, Telenor has expressed clearly that it intends to increase its investments in roll-out of fibre-based access networks. Moreover, upgrading of the copper network in the form of roll-out of VDSL with vectoring and/or G.fast may result in increased infrastructure competition for retail customers that request high capacities. This argument is further supported by technological developments in HFC networks, where DOCSIS 3.1 will also be able to provide greater broadband capacity in these networks.

289. A pure projection of the competitive situation based on figure 28 suggests a levelling off or slight decrease in HFC-based broadband access, continued growth for fibre access and a corresponding decrease for copper access. However, in light of the possible upgrade of the copper network, it is not given that this development will be as clear further ahead. Broadband based on VDSL accounted for 33.9 % of the xDSL subscriptions at the end of 2017, an increase from 29.9 % from the end of 2016. Further upgrades of the copper network may lead to increased infrastructure competition in the coming years, even in geographical areas where alternative access networks have been developed or are planned. A major reason for this is that the copper cables up to and into households that in recent years have chosen broadband connection via fibre or HFC network have not usually been removed.

290. In summary, development in competition in the retail market for broadband access on a national basis suggests that the infrastructure competition in this market will increase in coming years. Combined with proportionate access regulation of provider(s) with significant market power, this lays the foundation for sustainable competition in the broadband market. There are no large, clearly defined, geographical areas that stand out from the rest of the country in terms of degree of homogeneity in the competitive conditions at an overarching level. In the following, we will analyse whether there are nevertheless any geographical differences in terms of different providers' networks / coverage, market shares, prices and product offerings that indicate that it is necessary to define different relevant geographical markets for broadband access.

2.5.3 Geographical differences in providers' networks and coverage

291. The report "Broadband Coverage 2018" from September 2018 that Analysys Mason prepared on assignment from Nkom (hereinafter "the Coverage Report") contains information on broadband coverage for different capacities and access technologies at the national level and the county level. In addition, the report contains a mapping of Norwegian households' freedom of choice in respect of access technologies and the number of broadband providers at the national level and the county level.

292. Nkom will base its assessment of geographical differences in different providers' networks and coverage in this section on information from the Coverage Report.

2.5.3.1 Differences at the national level

293. The developments in different access technologies' national coverage over the past five years is shown in figure 30.

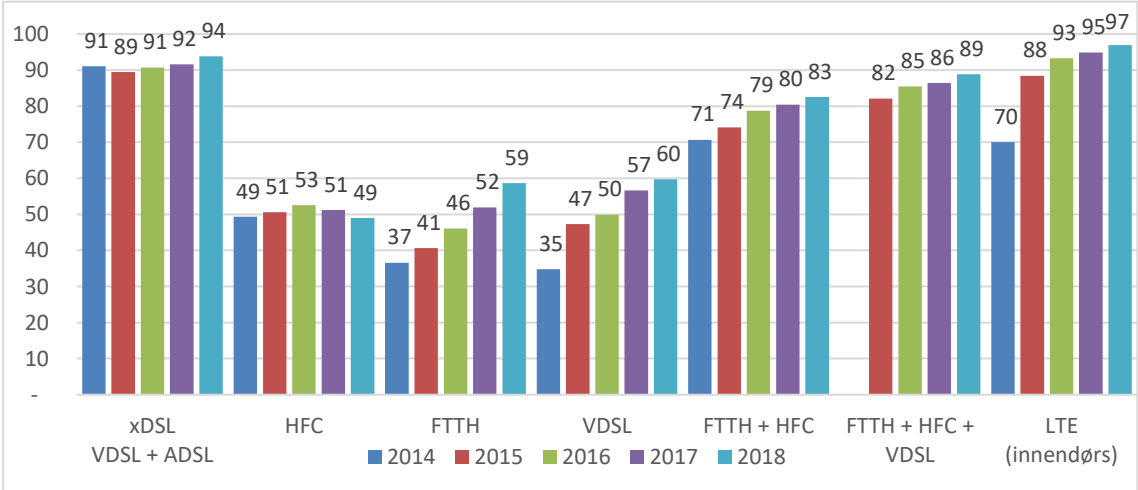

Figure 29: Estimated national coverage per access technology as a percentage of the number of households. (Source: Report "Broadband Coverage 2018")

294. Figure 30 shows that the combined xDSL coverage has had a slight increase in recent years, while VDSL has increased substantially in the same period, from 35% in 2014 to 60% in

2018. HFC coverage has increased slightly from 2014 to 2016, but fell in 2018 back to the 2016 level of 49%. Almost all the households with HFC coverage are now offered DOCSIS 3.0, enabling high capacities. The provision of fibre access has grown considerably in recent years, and coverage was 59% in 2018.

295. Approximately 83% of Norwegian households have a broadband offer based on either fibre or HFC network. Defining the sum of VDSL, HFC and fibre access networks as high-capacity broadband networks, the Coverage Report shows that around 89% of Norwegian households had an offer of high-capacity broadband access in 2018.

296. Although mobile broadband is not included in the same relevant product market as fixed broadband, it is interesting to note the strong growth in LTE / 4G coverage in recent years, on the basis of the view that mobile broadband is a potential source of competition to fixed broadband. Both Telenor and Telia have passed 95% population coverage for 4G.

297. The Coverage Report also contains information on the broadband users' freedom of choice, in terms of both number of access technologies and the number of broadband providers, broken down by different capacities.

298. Figure 31 shows the users' freedom of choice in respect of access technologies for different capacities. Although freedom of choice diminishes as capacity requirements increase, the Coverage Report shows that technology / infrastructure competition has increased in recent years, and for users requiring higher capacities. For example, in 2018 47% of households in Norway could choose between at least two technologies for 30 Mbit/s downstream capacity, while the corresponding figure for 2016 was 39%. For 50 Mbit/s or higher there was a corresponding development³¹. This indicates that the customers' freedom of choice in respect of the number of alternative access technologies is increasing also for capacities that require roll-out of new access networks or upgrading of existing networks.

³¹ In the survey for 2018, the capacity class of 50/10 Mbit/s has been replaced by 100/10 Mbit/s.

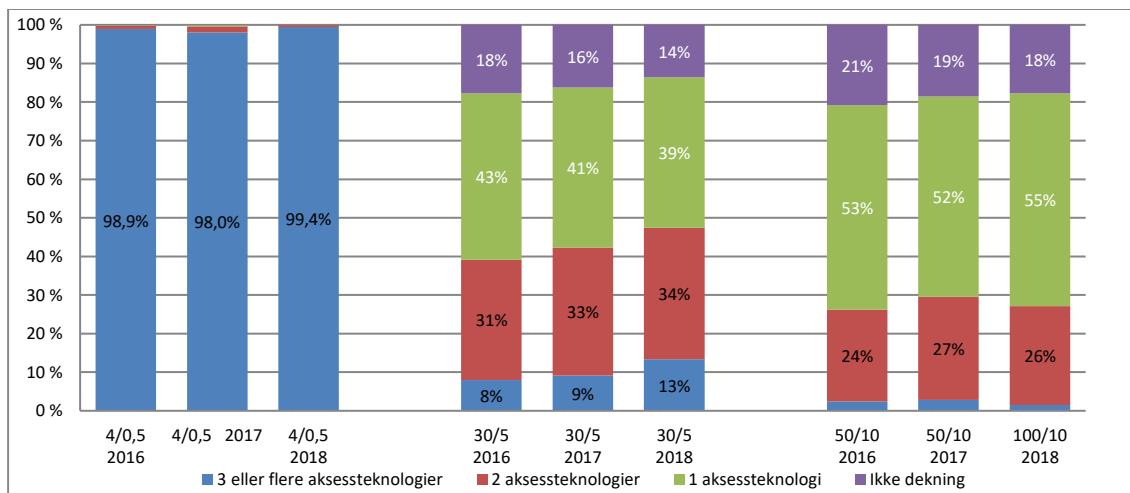

Figure 30: Freedom of choice between access technologies within different capacity classes from 2016 to 2018. (Source: Report “Broadband Coverage 2018”)

299. Developments in broadband users’ freedom of choice in respect of the number of broadband providers draws a similar picture, cf. figure 32. A total of 99.9 % of Norway’s population can choose between at least two providers of broadband access for capacities of 4 Mbit/s. When it comes to higher capacities, the situation is different, but also here it is interesting to note the increase in recent years in the proportion of Norwegian households that have offers of 50 Mbit/s from more than one provider. This development is expected to continue, also as a result of a possible vectoring / G.fast upgrade of the copper network.

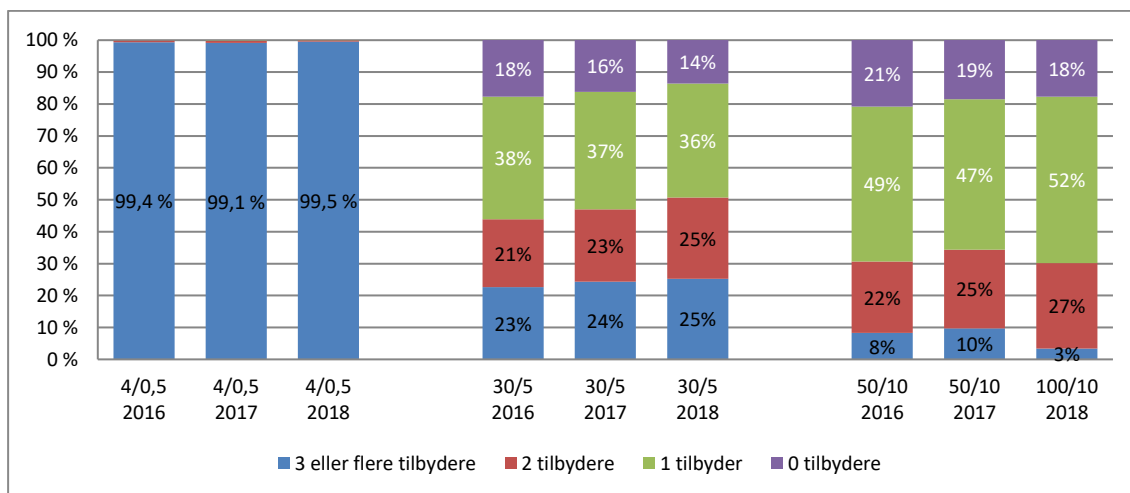

Figure 31: Freedom of choice between broadband providers within different capacity classes from 2016 to 2018. (Source: Report “Broadband Coverage 2018”)

2.5.3.2 Differences at the county level

300. Although information at the national level provides a good general overview of the prevalence of the different networks and access technologies and broadband users’ options in respect of access technologies and the number of providers on a nationwide basis, the information in the Coverage Report on coverage and users’ freedom of choice at the county

level is more interesting for Nkom’s analysis of the degree of homogeneity in the competitive conditions in different geographical areas.

301. Figure 33 shows that the high degree of coverage for lower capacities (up to 4 Mbit/s) at the national level is also largely reflected at the county level. Although there is variation between the counties, figure 33 shows that more than 98% of the households in all the counties can choose between at least three broadband providers for 4 Mbit/s access. The only exception in this context is Sogn og Fjordane, due to the high degree of satellite shade in this county, and only 94% of the households in the county have offers from at least three providers. This indicates that for lower capacities, there are no major differences in the competitive conditions between the counties of Norway, and that there is good competition for lower capacities in all the counties.

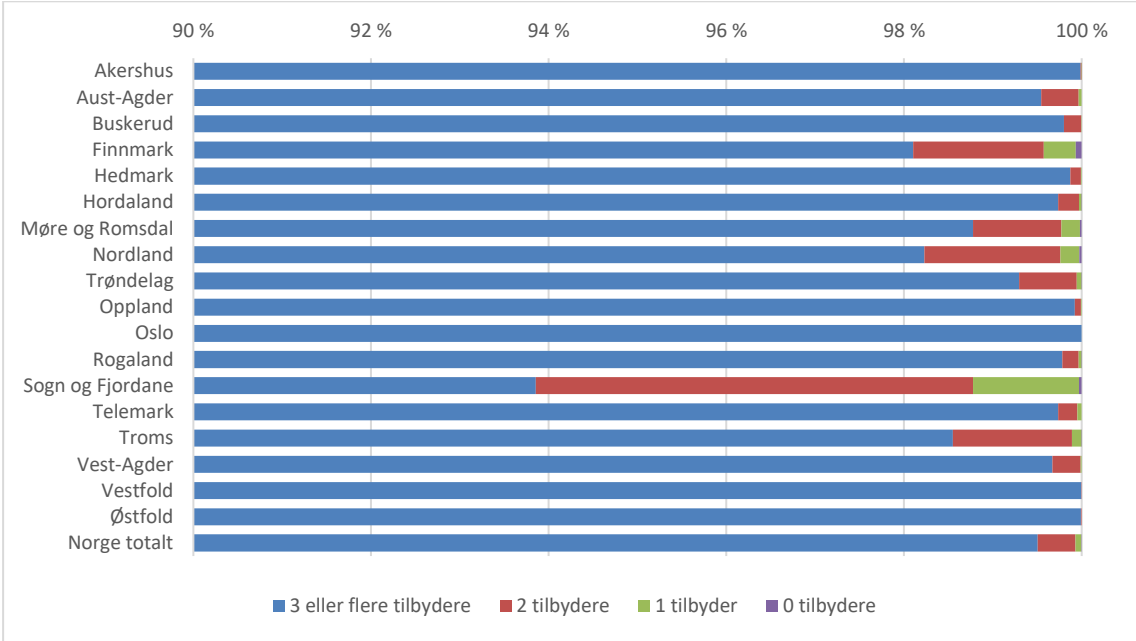

Figure 32: Number of different providers households can choose between by county. 4/0.5 Mbit/s (Source: Report “Broadband Coverage 2018”)

302. In the same way as at the national level, at the county level too the picture changes as capacity requirements increase. Figures 34 and 35 indicate households’ options in respect of number of broadband providers in the various counties for 30 and 50 Mbit/s respectively.

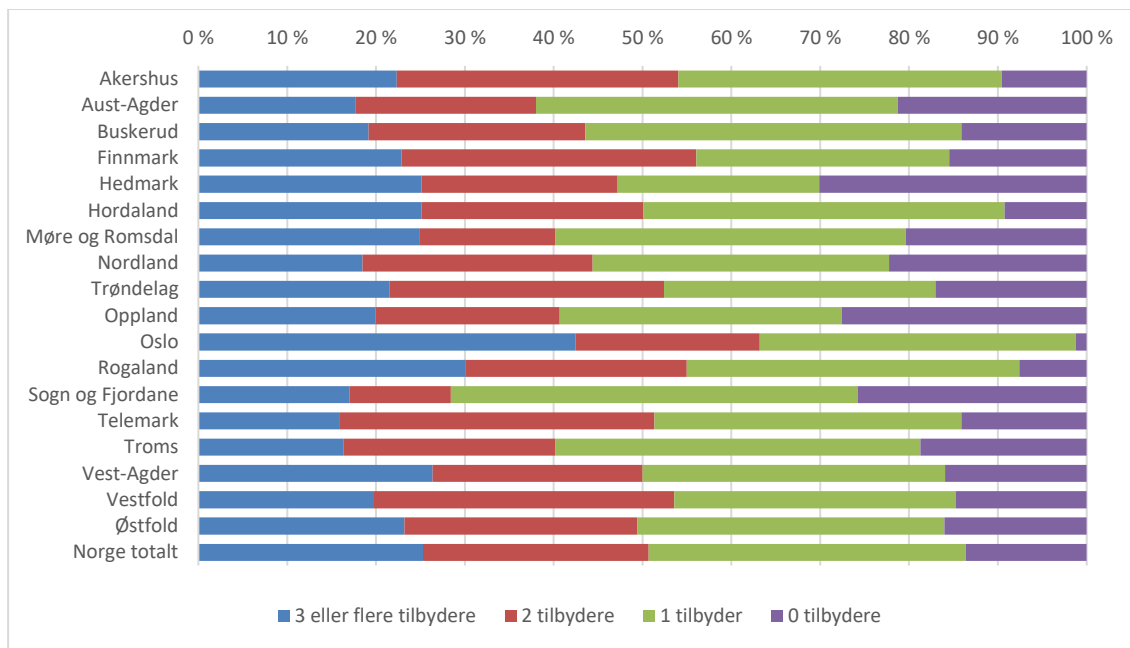

Figure 33: Number of different providers households can choose between by county. 30/5 Mbit/s (Source: Report “Broadband Coverage 2018”)

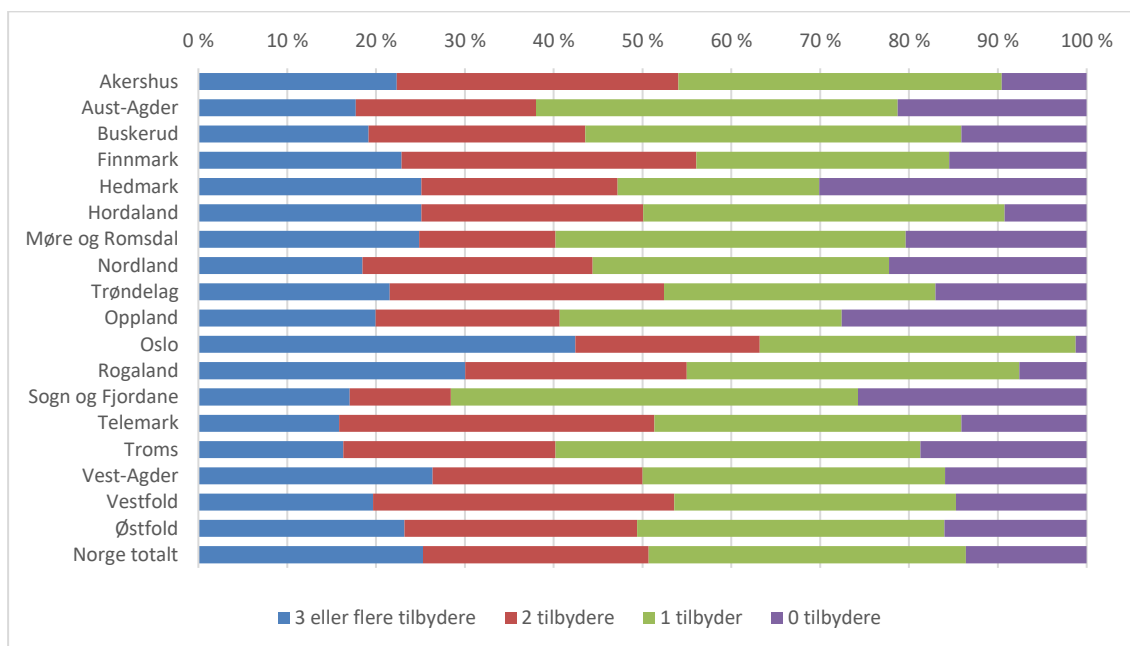

Figure 34: Number of different providers households can choose between by county. 100/10 Mbit/s (Source: Report “Broadband Coverage 2018”)

303. The respective figures for 30 and 100 Mbit/s vary widely between no, one, two and three providers in the various counties. These are nevertheless variations within the same general pattern, and Nkom believes that this does not provide grounds for concluding that the competition situation in some counties in Norway is so different from that in the other counties that this indicates the need to define different geographical markets based on county boundaries. On the contrary, Nkom finds that the county-level information in the Coverage

Report does not indicate that there is so little homogeneity in the competitive conditions between different counties, or groups of counties, in Norway that it seems necessary to categorise the counties into different relevant geographical markets for broadband access.

2.5.3.3 Differences between urban settlements and rural settlements

304. In addition to analyses on the national level and the county level, the Coverage Report also contains an analysis of differences in different networks' / access technologies' coverage in urban settlements (as defined by Statistics Norway) and rural settlements. This analysis indicates a clearer divide between urban settlements and rural settlements than between different counties in terms of broadband coverage. Figure 36 shows that this distinction applies to most access technologies, but that the difference is largest for technologies that offer higher capacities. For example 98% of households in urban settlements have an offer of VDSL, HFC or fibre access network, while the corresponding coverage in rural settlements is only around 49%.

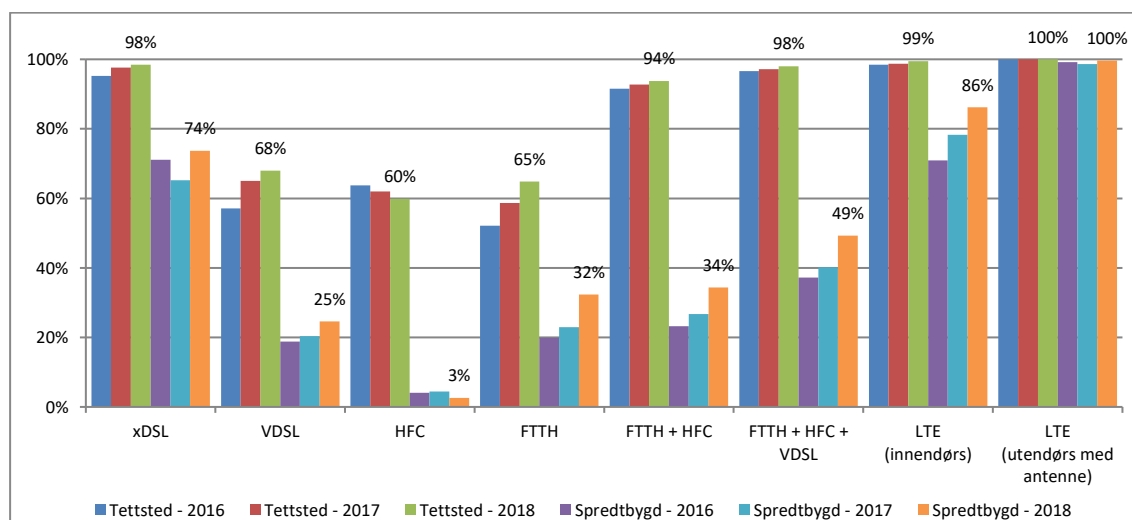

Figure 35: Estimated coverage for access technologies, by urban settlements and rural settlements (Source: Report “Broadband Coverage 2018”)

305. It is also worth noting that the largest relative increase for combined fibre, HFC and VDSL coverage in recent years has come in rural settlements. The increase in these areas was 9 percentage points from 2017 to 2018, while the corresponding increase in urban settlements was 1 percentage point.

306. The Coverage Report also points out that several fibre providers have used roll-out models that have been adapted for use outside urban settlements. This is exemplified in the report by the fact that in many areas there are clusters of houses that are not registered as urban settlements in Statistics Norway’s statistics because there are too few households, but where it can still be commercially viable to roll out fibre, if there is a transport network nearby or roll-out is based on a combination of public support, voluntary community effort and flexible set-up fees.

307. Although the Coverage Report shows a clear difference in the roll-out of higher speeds between urban settlements and rural settlements, the development is towards a closing of this gap. Nkom therefore finds that there is no basis for concluding that the competitive situation between urban settlements and rural settlements ought to be defined as separate geographical markets.

2.5.4 Number of providers in the retail market, and their market shares, at the municipal level

308. The results of Statistics Norway's internet survey for the second quarter of 2018 were published in September 2018. This survey provides an overview of the number of fixed broadband subscriptions in the residential and business markets, broadband as a proportion, and average speeds. According to the Statistics Norway survey, there were 129 providers of fixed broadband to residential subscribers in the second quarter of 2018. By way of comparison, 125 providers have reported data for the coverage report for 2018, and 133 providers have reported data for the eCom statistics for first half of 2018.

309. In addition, in February 2016 Statistics Norway published an analysis of the competitive situation in the local broadband market for the period 2013–2015³². This analysis provides information on the number of providers and their market shares, at the municipal level, making it relevant as a basis for analysis of the degree of homogeneity in the competitive conditions in different geographical areas. In this analysis, Statistics Norway grouped broadband providers into three categories: six national providers, 46 regional providers and 82 local providers.

310. In Nkom's opinion, Statistics Norway's analysis reveals a competitive situation that does not allow categorisation of Norwegian municipalities into geographical markets on the basis of varying degrees of competition. The analysis indicates that there is a mix of different competitive situations in a dynamic market, with national, regional and local providers, and it shows that the average number of providers per municipality is growing. Statistics Norway concludes that the competition in local markets for fixed, residential broadband access has increased since 2013. This conclusion is based on the following findings, among others:

- No municipalities had fewer than two providers of broadband access in 2015. At the same time only four municipalities had only two providers. This means that more than 99% of municipalities had three or more providers.
- In 97% of the municipalities there were at least four providers in 2015, up from 93% in 2013. Correspondingly, the number of municipalities with five providers increased from 70% in 2013 to 87% in 2015.
- The average number of providers per municipality increased from 5.7 in 2013 to 6.1 in 2015.

³² <http://www.ssb.no/teknologi-og-innovasjon/artikler-og-publikasjoner/okt-konkurranse-i-det-lokale-bredbandsmarkedet>

- Of the 134 broadband providers in Norway, 79 are the largest provider in at least one municipality:
 - Five out of six national providers are the largest provider in 230 municipalities
 - 30 out of 46 regional providers are the largest provider in 139 municipalities
 - 44 out of 82 local providers are the largest provider in 59 municipalities

At the same time, Telenor, including Canal Digital, is still the largest provider in 208 municipalities.

- On average, the market share of the largest provider in a municipality was 58% in 2015; however, market shares ranged from 25% to 98%. The average market share of the largest provider in the municipalities in 2013 was 59%.

2.5.5 Geographical differences in prices and product offerings

311. If there are distinct differences in prices and product offerings between areas with limited competition compared with areas with a higher degree of competition, this will weigh in favour of defining different geographical markets on the basis of different degrees of competition. Against this backdrop, Nkom has assessed the price and product offerings of 23 selected broadband providers.

312. The selected providers represent different business models and access technologies and constitute a good mix of national, regional and local providers. Nkom has attached importance to ensuring that the analysis includes a certain number of providers that operate in areas where there is reason to assume that competition is limited, so that the prices and offerings of these kinds of operators can be compared with the prices and offerings of operators that also operate in areas with a higher degree of competition.

313. The selected providers can be categorised as follows:

- Eight local fibre developers that are members of the Altibox alliance and offer broadband access in geographical areas with assumed limited competition (Bykle Breiband, Fitjar Kraftlag, Vesterålskraft Bredbånd, Finnås Kraftlag, Fusa Kraftlag, Tysnes Breiband, Etne Ellag and Hardangernett).
- Seven local providers that are not Altibox partners and that offer broadband access based on a mix of fibre, HFC and radio networks in areas with assumed limited competition (Hammerfest Energi Bredbånd, 3Net, Modum Kabel-TV, Nornett, Øvre Eiker Fibernet, Årdalsnett and Svorka aksess).
- Three regional fibre developers that are Altibox partners and that offer broadband access in both urban settlements and rural settlements (NTE Bredbånd, Viken Fiber and Lyse Fiber).

- Two regional providers that are not Altibox partners and that offer broadband access with a mix of access technologies in both urban settlements and rural settlements (Enivest Bredbånd and Eidsiva Bredbånd).
- Two national providers with a mix of access technologies: one access network owner and one buyer of access (Telenor and NextGenTel).
- One national provider of broadband via HFC network (Get).

314. Nkom compared the prices and product offerings of these selected providers in April 2016 and August 2017. The relevant findings from the assessment of prices and product offerings are described below, in view of the purpose of the assessment, which is to determine whether there are distinct differences in prices and product offerings between areas with different competitive conditions. The assessment is mainly based on the prices and product offerings from the survey in August 2017, but relevant developments from April 2016 to August 2017 have also been included in the assessment.

2.5.5.1 Assessment of geographical differences in prices due to different competitive conditions

315. To ensure that the assessment of price differences is based on the most comparable prices possible for the various providers, Nkom has applied the following assumptions to the price comparison:

- Nkom has assessed the providers' prices in the detached home segment of the private market without including prices for cooperative housing customers in the assessment.
- Nkom has assessed the monthly prices for Internet access at different speeds, as well as prices for the new establishment of access connections.
- Prices for other broadband services such as TV channels/packages, broadband telephony, etc. are not included in the assessment of price differences. Comparison of the operators' offerings of such services is included, however, in the assessment in Section 2.5.5.2 of differences in the operators' product offerings.
- The assessment is based on price lists published on the providers' websites in May 2018, August 2017 and April 2016, respectively, and thus does not capture any time/location-limited campaign prices or special offers that are not included in the price information on the websites of the providers at these times, or any price changes after May 2018.
- When the national providers' price lists do not state the geographical differentiation of prices, it is assumed that the prices are the same throughout the country.

316. The broadband providers have productised and commercialised various different broadband capacities. In order to make appropriate comparisons of the providers' prices,

Nkom has therefore grouped the various capacity offerings in the market in the following six categories:

- Below 10 Mbit/s
- Between 10 and 25 Mbit/s
- Between 30 and 40 Mbit/s
- Between 50 and 70 Mbit/s
- Between 75 and 100 Mbit/s
- Over 100 Mbit/s

317. Within each of these capacity categories, Nkom has assessed whether there are distinct price differences between providers operating in areas with a high degree of competition, compared with providers offering broadband access in areas where the competition is assumed to be more limited. Below, we have summarised the findings within each capacity category.

Monthly prices for Internet capacities below 10 Mbit/s

318. Table 3 below shows that six of the selected operators have included prices for capacities below 10 Mbit/s in their price lists. The prices in parenthesis are campaign prices for DSL that apply for a limited number of months: three months for the national network owner, six months for the national access buyer and 12 months for the regional provider.

319. Table 3 shows that the regional DSL provider has a slightly lower price for 5 Mbit/s than the national DSL providers. The table also shows that the two local providers which offer capacities below 10 Mbit/s based on HFC or fibre access do not operate with higher prices than the national DSL providers, if we disregard the time-limited campaign prices of the national DSL providers.

320. The table also shows that the two radio-based offerings in this capacity category are priced higher than the offerings which are based on other access technologies. It should also be noted that if the broadband customer does not buy landline telephony from the national DSL provider which is the access buyer, the monthly price increases by NOK 109. In addition, this access buyer operates with a router lease charge of NOK 24 per month. This means that a national DSL provider operates with a higher monthly price in this capacity category for broadband customers without landline telephony than local HFC/fibre providers operating in areas with assumed limited competition, and that the national access buyer's DSL price for 2 and 5 Mbit/s is at around the same level as the price for the radio-based 5 Mbit/s offering in an area with assumed limited competition.

Provider	Access technology	Price 1.5 Mbit/s	Price 2 Mbit/s	Price 3 Mbit/s	Price 5 Mbit/s
Regional provider, not Altibox partner	Radio/DSL	348		498 (398)	298 (198)

Local provider, not Altibox partner	HFC/Fibre				329
Local provider, not Altibox partner	HFC				349
Local provider, not Altibox partner	Radio				449
National provider, network owner	DSL				359 (299)
National provider, access buyer	DSL		329 (299)		329 (299)

Table 3: Comparison of providers' prices for capacities below 10 Mbit/s as of May 2018. (Source: the providers' websites.)

321. For this capacity category there is thus no clear pattern with regard to price differences between providers operating in areas with a high degree of competition, compared with providers offering broadband access in areas where the competition is assumed to be more limited.

Monthly prices for Internet capacities between 10 and 25 Mbit/s

322. In this capacity category, there is a rather wider basis for comparison. Table 4 shows that six of the local providers with their own HFC/fibre network, two regional providers with DSL- and radio-based offerings, and both the national DSL providers, have stated prices in this capacity category. In the same way as for capacities below 10 Mbit/s, the prices in parenthesis in Table 4 are campaign prices for DSL which apply for a limited number of months: three months for the national network owner, six months for the national access buyer and 12 months for the regional provider. Moreover, in this case too, the DSL prices for the national access buyer will be NOK 109 higher than the table shows, if the broadband customer does not buy landline telephony.

Provider	Access technology	Price 10 Mbit/s	Price 15 Mbit/s	Price 20 Mbit/s	Price 25 Mbit/s
Regional provider, not Altibox partner	DSL/Radio	348 (248) / 498		398 (298) / 548	
Regional provider, not Altibox partner	DSL		389		
Local provider, not Altibox partner	Fibre	399			
Local provider, not Altibox partner	HFC	299			399
Local provider, not Altibox partner	Fibre/HFC				399
Local provider, not Altibox partner	Fibre/HFC				429
Local provider, not Altibox partner	HFC		399		
Local provider, not Altibox partner	Radio		549		
National provider, network owner	DSL	379 (299)		429 (299)	
National provider, access buyer	DSL	329 (299)		329 (299)	

Table 4: Comparison of providers' prices for capacities between 10 and 25 Mbit/s as of May 2018. (Source: the providers' websites.)

323. With this as the starting point, a comparison of prices for Internet capacities between 10 and 25 Mbit/s does not indicate any clear price differences as a consequence of various

competitive conditions. The time-limited campaign prices for DSL access of national and regional providers are lower than those of the local and regional HFC/fibre providers in this capacity category. At the same time, the national network owner operates with a higher DSL price for 20 Mbit/s after the first three months than the monthly prices for 25 Mbit/s of most local and regional HFC/fibre providers in this capacity category. As for capacities below 10 Mbit/s, in this capacity category too, the prices for radio-based broadband access are higher than for the other access technologies.

324. Overall, this implies that the prices from providers in this capacity category that offer broadband access in areas where the competition is assumed to be more limited do not differ significantly from the prices of the national and regional providers that also operate in areas exposed to greater competition.

Monthly prices for Internet capacities between 30 and 40 Mbit/s

325. Six local providers, four regional providers, and both of the two national DSL providers have stated prices in this capacity category in their price lists.

326. Table 5 shows that also in this capacity category there is no clear pattern with regard to price differences as a consequence of varying terms of competition. For example, several local and regional fibre operators in areas with assumed limited competition offer 40 Mbit/s symmetrical capacities at prices that are only slightly higher than those of the national and regional providers of 30 and 35 Mbit/s asymmetrical capacities.

Provider	Access technology	Price 30 Mbit/s	Price 35 Mbit/s	Price 40 Mbit/s
Regional provider, not Altibox partner	DSL/Radio	448 (348) / 598		
Regional provider, not Altibox partner	DSL			469
Local provider, not Altibox partner	Fibre		449	
Local provider, not Altibox partner	Radio	749		
Local provider, Altibox partner	Fibre			499
Local provider, Altibox partner	Fibre			498
Local provider, Altibox partner	Fibre			549
Local provider, Altibox partner	Fibre			519
Regional provider, Altibox partner	Fibre			519
Regional provider, Altibox partner	Fibre			519
National provider, network owner	DSL	479 (299)		
National provider, access buyer	DSL	399 (299)		499 (299)

Table 5: Comparison of providers' prices for capacities between 30 and 40 Mbit/s as of May 2018. (Source: the providers' websites.)

327. In this capacity category too, there are no distinct price differences between providers operating in areas with a high degree of competition, compared with providers offering broadband access in areas where the competition is assumed to be more limited.

Monthly prices for Internet capacities between 50 and 70 Mbit/s

328. Nine of the selected local and regional broadband providers and all three national operators included in this price comparison have stated prices in this capacity category in their price lists.

329. Table 6 shows that the prices for 50-70 Mbit/s are between NOK 499 and 599 both in areas exposed to competition and in geographical areas with more limited competition. The only exception is one of the national providers, which operates at a rather higher price for 60 Mbit/s than the other providers in this price comparison. For the sake of good order, Nkom points out that the different prices for 50 and 60 Mbit/s from the national network owner that offers DSL, HFC and fibre access in this capacity category are due to different prices for different access technologies.

330. Several of the local providers which offer broadband access in areas where it can be assumed that the competition is limited have reduced their prices in this capacity category since the first survey in 2016. That means that the price differences between the various different providers in this category are lower today than a couple of years ago.

Provider	Access technology	Price 50 Mbit/s	Price 60 Mbit/s	Price 70 Mbit/s
Regional provider, not Altibox partner	DSL/Fiber	448 / 499		
Regional provider, not Altibox partner	HFC/Fibre	479		
Local provider, not Altibox partner	HFC/Fibre	499		
Local provider, not Altibox partner	HFC/Fibre	499		
Local provider, not Altibox partner	HFC	499		
Local provider, not Altibox partner	Fibre		499	
Local provider, not Altibox partner	HFC/Fibre		499	549
Local provider, not Altibox partner	HFC	549		
Regional provider, Altibox partner	Fibre	549		
National provider, network owner	HFC		639	
National provider, network owner	DSL/HFC/Fibre	599 /499	579 (299)	
National provider, access buyer	DSL/Fibre		499 (299) / 499	

Table 6: Comparison of providers' prices for capacities between 50 and 70 Mbit/s as of May 2018. (Source: the providers' websites.)

331. On this basis, neither the prices in Table 6 nor the price trend for this capacity category indicate that there are price differences in this category which are due to varying geographical competition conditions. On the contrary, Table 6 gives no indication that there are higher prices in areas with limited competition in this capacity category than in areas subject to a greater degree of competition.

332. All in all, this indicates that also in the 50-70 Mbit/s capacity category there is no clear distinction with regard to prices in geographical areas with limited competition and in geographical areas subject to a greater degree of competition.

Monthly prices for Internet capacities between 75 and 100 Mbit/s

333. In this capacity category, Nkom has compared the prices of 13 local and four regional broadband providers with the prices of the three national providers included in the price comparison. For the national network owner offering 100 Mbit/s based on both HFC and fibre access, the price for both access technologies is stated in Table 7.

334. Table 7 shows that one of the local providers stands out with a significantly lower price than the other operators (NOK 499 for 100 Mbit/s), while another local provider stands out with a considerably higher price than the other operators (NOK 799 for 80 Mbit/s). Otherwise, the prices in this capacity category lie between NOK 578 and NOK 699, and there is no clear pattern in terms of higher prices for operators in geographical areas with assumed limited competition than for operators which also offer these capacities in areas exposed to greater competition. On the contrary, the table below shows a complex picture in which some of the local/regional providers operate with slightly higher prices, others with slightly lower prices, and others again with prices which are more or less equivalent to those of national operators.

335. For this capacity category too, Nkom registers price reductions from 2016 to 2018 among several of the local providers operating in areas where competition is assumed to be limited.

336. All in all, this indicates that for this capacity category too, there is no clear distinction with regard to prices in geographical areas with limited competition and in geographical areas subject to a greater degree of competition.

Provider	Access technology	Price 75 Mbit/s	Price 80 Mbit/s	Price 100 Mbit/s
Regional provider, not Altibox partner	HFC/Fibre			649
Local provider, not Altibox partner	HFC/Fibre	649		
Local provider, not Altibox partner	Fibre			499
Local provider, not Altibox partner	HFC			599
Local provider, not Altibox partner	HFC/Fibre			549
Local provider, not Altibox partner	HFC/Fibre			599
Local provider, not Altibox partner	HFC/Fibre			549
Local provider, Altibox partner	Fibre		578	
Local provider, Altibox partner	Fibre		799	
Local provider, Altibox partner	Fibre		599	
Local provider, Altibox partner	Fibre		649	
Local provider, Altibox partner	Fibre		578	
Local provider, Altibox partner	Fibre		649	
Local provider, Altibox partner	Fibre		699	

Regional provider, Altibox partner	Fibre			649
Regional provider, Altibox partner	Fibre		629	
Regional provider, Altibox partner	Fibre		629	
National provider, network owner	HFC/Fibre			699 / 599
National provider, access buyer	Fibre			599

Table 7: Comparison of providers' prices for capacities between 75 and 100 Mbit/s as of May 2018. (Source: the providers' websites.)

Monthly prices for Internet capacities over 100 Mbit/s

337. All 22 broadband providers in this price comparison have stated prices in this capacity category in their price lists. This category comprises capacities from 120 to 1000 Mbit/s, and the price comparisons must therefore take into account that this capacity category spans wider than the other categories.

Provider	Access technology	Price 120 Mbit/s	Price 125 Mbit/s	Price 150 Mbit/s	Price 200 Mbit/s	Price 250 Mbit/s	Price 300 Mbit/s	Price 350 Mbit/s	Price 400 Mbit/s	Price 500 Mbit/s	Price 600 Mbit/s	Price 1000 Mbit/s
Local, not Altibox	Fibre			599			699			999		
Local, not Altibox	Fibre									899		1399
Local, not Altibox	Fibre		799			899						
Local, not Altibox	Fibre				849					1290		
Local, not Altibox	HFC								699			
Local, not Altibox	HFC/ Fibre				699							
Local, not Altibox	Fibre				799						999	
Local, not Altibox	Fibre			699								
Local, not Altibox	Fibre						649			899		
Local, Altibox	Fibre			649			749			990		1490
Local, Altibox	Fibre			899			1049			1299		2490
Local, Altibox	Fibre			649			749			990		1490
Local, Altibox	Fibre			849			949			1190		2490
Local, Altibox	Fibre			649			749			990		1490
Local, Altibox	Fibre			849			949			1190		
Local, Altibox	Fibre			899			1049			1299		
Regional, Altibox	Fibre			699			799			1029		1529
Regional, Altibox	Fibre			699			799			1029		1529
Regional, Altibox	Fibre			699			799			1029		1529
National, network owner	HFC	739				839		939		1249		
National, network owner	HFC/ Fibre					749 / 649				1149 / 1049		
National, access buyer	Fibre				799						999	

Table 8: Comparison of providers' prices for capacities over 100 Mbit/s as of May 2018.
(Source: the providers' websites.)

338. Table 8 shows that there are some large price variations in this category, and that some of the selected providers have significantly higher prices than the other providers. 500 Mbit/s is the capacity offered by most operators in this capacity category, including both of the national network owners included in this survey. A comparison of the 500 Mbit/s prices shows that the national providers' prices are not among the lowest. Nine local/regional broadband providers operate with lower prices for 500 Mbit/s than Telenor, while five local/regional providers have higher 500 Mbit/s prices than Telenor. Comparison with the other national provider's 500 Mbit/s price shows that only two of the fourteen local/regional providers have higher prices for 500 Mbit/s than Get. This indicates that in this category, too, there is no price distinction between providers offering broadband access in areas where competition is assumed to be limited, compared with national providers, which indicates that various geographical markets should be defined according to varying degrees of competition.

Prices for new establishment of access connections for broadband access

339. Providers that base their broadband offerings on the establishment of new access networks for their customers often operate with set-up prices in addition to the monthly prices for Internet access. Not all of the selected providers that build such new access networks have stated set-up prices in price lists on their websites. Table 9 nonetheless shows that the set-up prices of the selected providers operating with price lists that include prices for such new establishment of access connections range from around NOK 2,000 to around NOK 6,000. This is basically a significant price difference. At the same time, various different set-up prices often tend to reflect various levels of own contribution by the customer on the establishment of new access networks. Some of the selected providers operate with different prices for establishment with and without the customer's own contribution. A couple of the providers also have different set-up prices for overhead drawing and buried cables into the dwelling.

Provider	Access technology	Price of establishment
Local provider, not Altibox partner	Fibre	3990
Local provider, Altibox partner	Fibre	4000/8000
Local provider, Altibox partner	Fibre	4995
Local provider, Altibox partner	Fibre	1900/2900/4400
Local provider, Altibox partner	Fibre	1990/2400/4800
Local provider, Altibox partner	Fibre	2900
Local provider, Altibox partner	Fibre	6000
Local provider, Altibox partner	Fibre	6250
Local provider, Altibox partner	Fibre	4900
Regional provider, Altibox partner	Fibre	2400/5400
Regional provider, Altibox partner	Fibre	1999/5999
Regional provider, Altibox partner	Fibre	1990
National provider, network owner	Fibre	4990

Table 9: Comparison of providers' prices for new establishment of access connections for broadband access as of May 2018. (Source: the providers' websites.)

340. It is furthermore assumed that in some cases the price differences in Table 9 reflect actual cost differences related to the establishment of customer accesses in different geographical areas. All other things being equal, the development of new access networks in sparsely populated areas with few homes in the relevant area will entail higher set-up costs per customer access than the development of access networks in densely built-up areas with a broader customer base within the geographical area.

341. Some of the selected local/regional providers that offer broadband access based on the establishment of fibre access networks in geographical areas with assumed limited competition operate with lower set-up prices than Telenor's price for the establishment of fibre access networks, while others have higher set-up prices in their price lists. In other words, also for set-up prices it is not possible to see a clear distinction between the price level of the national provider and local providers that establish new access connections in areas subject to assumed limited competition.

Summary of assessments of geographical differences in prices due to varying competitive conditions

342. Comparison of the selected providers' monthly prices for Internet access and prices for new establishment of access connections for broadband access does not display a clear pattern with regard to local and regional providers in areas subject to assumed limited competition operating with significantly higher prices than national providers that also offer broadband access in areas subject to greater competition. Even though some of the local and regional providers within a few of the capacity categories have higher prices than the national providers, the price differences between local/regional and national providers are not so clear across the capacity categories as to clearly indicate a need to define geographical markets that are more limited than the national market. The differences in set-up prices are not so large and clear as to provide any basis for such a conclusion.

343. In Nkom's assessment, on the contrary, the comparison of the 22 selected broadband providers' prices indicates that there is no clear distinction with regard to end-user prices between areas subject to assumed limited competition and areas with a greater degree of competition. The tables above show a complex picture, where for some capacities operators in areas subject to assumed limited competition have rather higher prices than national operators, but also where some of the local/regional providers have lower prices than national operators for given capacities.

344. Taking account of the difference between symmetrical and asymmetrical capacities, the picture becomes even less clear, since in some cases a few of the local/regional fibre operators offer symmetrical capacities at prices which are lower than, or approximately equivalent to, national operators' offering of asymmetrical capacities.

345. Nkom furthermore assumes that higher prices among some local providers operating in sparsely populated areas than among national providers may also have other reasons than

varying levels of competition. For example, it is assumed that small, local operators that primarily offer broadband access in sparsely populated areas may have higher transport network costs than national and regional providers. Furthermore, the development of new access networks will entail a certain ratio of customer-independent fixed costs, which means that operators with larger customer bases in densely built-up areas will be able to achieve lower costs per customer than operators with lower numbers of customers in more sparsely populated areas.

2.5.5.2 Assessment of geographical differences in product offerings due to different competitive conditions

346. If there are distinct differences in product offerings between operators that primarily offer broadband access in areas with limited competition compared with operators that also operate in areas where there is a higher degree of competition, this may weigh in favour of defining different geographical markets on the basis of different degrees of competition. On this basis, Nkom has also undertaken a comparison of the product offerings of the 23 selected broadband providers.

347. The comparison of product offerings indicates that it is primarily the providers' choice of access technologies that determines what products a broadband provider offers, and that the product offering only seems to vary with different levels of competition in geographical areas to a limited degree. For example, fibre operators generally offer more capacities in the capacity category "Over 100 Mbit/s" than providers that use other access technologies, regardless of competitive conditions and regardless of whether the provider operates on the local, regional or national level.

348. Nor when it comes to the provision of services other than internet access via broadband connection does degree of competition appear to play a significant role. Most of the selected fibre and HFC providers seem to offer TV services and voice over broadband services as well as internet access, regardless of the competitive conditions, and there are no significant differences in respect of the content of the TV services offered.

349. On this basis, no differences have been identified in the broadband providers' product offerings based on various competitive factors that indicate that it is necessary to define different geographical markets for broadband access.

2.5.6 Summary and conclusion of the assessment of geographical markets for broadband access

350. Although the prevalence of broadband networks offering high capacities varies between urban and rural settlements, Nkom's overall assessment of the indicators that, pursuant to BEREC's Common Position, ought to be considered when determining geographical markets is that it is not necessary to carry out a more detailed geographical analysis to be able to conclude that the geographical market for wholesale broadband access

in Norway ought still to be delimited nationally. The analysis on which this conclusion builds is based on both different networks' coverage and the competition situation in the retail market.

351. In Nkom's opinion, there are no clear differences in the competitive conditions in the retail market in stable and clearly delimited parts of the country that indicate that it is necessary to subdivide the associated wholesale markets geographically. The comparison of the retail prices of 23 selected broadband providers, representing both local providers that primarily operate in geographical areas with assumed limited competition and national operators that also offer broadband access in areas with a higher degree of competition revealed a complex situation in terms of prices. The price comparison does not provide grounds to conclude that there are clear and unambiguous price differences between geographical areas with assumed limited competition and areas with a higher level of competition, making it necessary to define different geographical markets for broadband access at the wholesale level in Norway. The other indicators that Nkom has assessed above in line with BEREC's Common Position also lead in the same direction.

352. The price comparison that Nkom has carried out further indicates that potential competition in the retail market from mobile broadband, the possible upgrade of the copper access network and Telenor's increased investment in fibre access roll-out seem to have a disciplining effect on the pricing of local fibre operators that operate in geographical areas with limited competition from other high-capacity networks. Nkom assumes that this potential competition has been a contributing factor in the above-mentioned price reductions from several local fibre operators from April 2016 to August 2017.

353. Although Nkom does not consider that there is sufficient substitutability between fixed and mobile broadband access that it can be concluded that fixed and mobile broadband access are part of the same relevant product market (cf. Section 2.3.3), based on the price comparison, it is natural to look at the virtually nationwide supply of mobile broadband with ever higher capacities as a factor that disciplines the price-setting of providers of fixed broadband access that operate in geographical areas without much competition in the fixed access market.

354. Similarly, the price comparison may indicate that even in areas where the copper access network has not been able to provide high-capacity broadband access, the possibility of technology development in the copper access network is perceived as a potential competitive factor. Telenor's increased investment in the establishment of fibre access networks in the residential market further supports this view. The price comparisons that Nkom has conducted do not draw a straight-forward picture of high-capacity network providers in these kinds of areas charging higher prices than high-capacity network providers in areas with a greater degree of competition.

355. Moreover, the roll-out of broadband access networks for higher capacities is a dynamic, ongoing process, and it is important in this context that geographical markets are not defined

that fail to take this market dynamic into account. Norwegian authorities want to stimulate the roll-out of high-capacity broadband networks in areas where this kind of development has not yet taken place. To reach the target defined in the Electronic Communications Plan of 90% 100 Mbit/s coverage by 2020, ex-ante regulation of the broadband market must provide incentives for continued development of high-capacity networks. In Nkom's view, subdividing the market for broadband access into several geographical markets will not necessarily contribute to increased incentives for this kind of development.

356. On this basis, Nkom finds that Market 3a and Market 3b are geographically limited to Norway.

2.6 Conclusion concerning market definition

357. The retail market for standardised broadband access includes all the fixed access technologies: copper, fibre, HFC, and fixed radio access networks. Mobile network-based broadband access and access products that are requested by companies that need access solutions with greater functionality and/or quality than is provided by standardised mass market products are not included in the relevant retail market for standardised broadband access. However, fixed radio access (point-to-point and point-to-multipoint connections) is part of this relevant market.

358. The market for wholesale local access (Market 3a) and the market for wholesale central access (Market 3b) are two separate markets. Both markets are technology neutral and are derived from the retail market for standardised broadband access.

359. Market 3a comprises access to physical wholesale products, as well as equivalent or comparable virtual wholesale products in the copper and fibre networks that have the following characteristics: 1) local access, 2) service-independent, "uncontended" connection, and 3) the access buyer has control of the connection. Nkom finds that wholesale products based on copper and fibre networks are included in Market 3a.

360. Market 3b comprises wholesale access at regional or central levels, and wholesale access offered at local level, but does not fulfil the other requirements for products in Market 3a. Nkom finds that wholesale products based on copper, fibre, HFC and fixed radio-access networks are included in Market 3b.

361. The wholesale products included in Market 3a comprise access to products that enable buyers of access greater and more flexible control over the access lines than the wholesale products in Market 3b.

362. Both Market 3a and Market 3b include external sales and internal sales of broadband access products via relevant fixed access technologies used for broadband access in the retail market for standardised broadband access.

363. Leased lines and access products that are requested by companies that need access solutions with greater functionality and/or quality than is provided by standardised mass market products are not included in Market 3a or Market 3b.

364. Market 3a and Market 3b are both defined geographically as Norway.

3 Analysis of Market 3a and Market 3b

3.1 Framework for assessment of significant market power

365. It is stated in Section 3-3 of the Electronic Communications Act that the Authority shall regularly³³ perform market analyses of relevant product and services markets in order to examine whether the markets are subject to effective competition. If the markets are not subject to effective competition, Nkom must identify providers that alone or together with other providers hold significant market power.

366. Significant market power is defined in Section 3-1, first paragraph, of the Electronic Communications Act, as follows:

“A provider has significant market power when the provider individually or jointly with others has economic strength in a relevant market affording the provider the power to behave to an appreciable extent independently of competitors, customers and consumers. Significant market power in one market may result in a provider having significant market power in a closely related market.”

367. In paragraph 19 of the Guidelines, ESA writes:

“In respect of each of these relevant markets, NRAs will assess whether the competition is effective. A finding that effective competition exists on a relevant market is equivalent to a finding that no operator enjoys a single or joint dominant position on that market. When NRAs conclude that a relevant market is not effectively competitive, they will designate undertakings with SMP on that market”

368. The preparatory works to the Electronic Communications Act also state:

“Sustainable competition is defined as a situation where no operator has significant market power and/or is able to exploit its position to the detriment of competition.”

369. Thus, according to the regulatory framework, there will be a necessary correlation between the absence of effective competition in a relevant market and the existence of significant market power.

³³ Cf. also section 9.3, second paragraph, of the Electronic Communications Act.

370. The assessment of significant market power shall be based on a “Modified Greenfield Approach”. This means that the assessment must be conducted on the assumption that the relevant market covered by the market analysis is not subject to sector-specific ex-ante regulation. This kind of approach is necessary to avoid disciplining effects of ex-ante regulation in the relevant market being taken into consideration when assessing whether any significant market power exists in the same market. Other regulation that directly affects the relevant market, and regulation in adjacent markets ought nevertheless to be taken into account.

371. As stated in Section 1.2, Telenor has been designated as a provider with significant market power in the former Markets 4 and 5 several times in the past. Pursuant to Nkom’s decision from 2014, Telenor is currently subject to an access obligation, an obligation of non-discrimination, price controls and an obligation of transparency in both markets. The analysis takes into account the fact that to date regulation has affected the relevant market conditions.

372. In Section 2.4 above Nkom defined two relevant wholesale markets: the market for wholesale local access (Market 3a) and the market for wholesale central access (Market 3b). In the following, Nkom will assess whether there is a basis for designating one or several providers with significant market power in these markets.

373. The analysis of the two markets has been based on the guidelines in the Commission’s Explanatory Note and the corresponding description of the relevant markets. The starting point for the analysis shall, according to the Commission’s Explanatory Note, be the wholesale market that contains the least refined products. Wholesale markets with more refined products are then analysed, with a view to ascertaining whether these demonstrate effective competition and thus the extent to which it is necessary to impose further specific obligations on a provider with significant market power³⁴.

374. For practical reasons, Nkom finds it appropriate to assess the competitive situation in Market 3a and Market 3b in the same document, as the markets are closely connected and the competitive conditions in the markets have a reciprocal effect on one another. For each criterion that is assessed, Nkom indicates whether the assessments were identical for both markets or whether they were carried out separately for each market. Finally, Nkom draws a conclusion for each of the markets separately.

375. The market analysis was performed on the basis of data, i.e. the electronic communications statistics and the collection of qualitative data, and dialogue with representative companies to find out how these companies experience the competition in the markets.

³⁴ The Commission’s Explanatory Note, page 15.

3.2 General – significant market power

376. Section 3-1 of the Electronic Communications Act states that a provider “individually or jointly with others” may have significant market power. When a provider has significant market power alone, this is referred to as individual dominance; if several providers together can behave independently of their customers, competitors and consumers to an appreciable extent, it is referred to as collective dominance. The term “significant market power” in the Electronic Communications Act is very close to the competition law standard of “dominant position”.

377. According to competition theory³⁵, a company with a high degree of market power is characterised by the fact that it is not exposed to effective competition pressure. Market power is defined as the opportunity to influence prices, innovation, selection of goods and services, or other parameters of competition during a relevant period of time. Nkom’s analysis of significant market power has a short to medium-term perspective: in practice, probably two to three years.

378. A natural starting point for analyses of significant market power is to assess market shares, cf. paragraph 76 of the Guidelines. Nkom’s analysis of significant market power is therefore based on the providers’ market shares.

379. It is stated in paragraph 79 of the Guidelines that market shares alone are generally insufficient to determine whether a provider has significant market power, but must be viewed in context with the other relevant assessment criteria that affect an operator’s ability to behave independently of the market.

380. The relative significance of the individual criteria may vary in different markets, depending on the characteristics and dynamics of the individual market. The criteria are assessed separately, but there may be a certain degree of overlap. In this connection, the Guidelines state³⁶:

“A dominant position can derive from a combination of the above criteria, which taken separately may not necessarily be determinative.”

381. In addition to market share, Nkom has assessed the following criteria in its assessment of market power in Market 3a and Market 3b:

- The size of the companies
- Price developments
- Complaints, appeals and supervisory matters
- Control of infrastructure that is not easily duplicated
- Sunk costs

³⁵ DG Competition, Discussion Paper on the application of Article 82 of the Treaty to exclusionary abuses, page 23.

³⁶ Cf. paragraph 80 of the Guidelines.

- Vertical and horizontal integration
- Economies of scale and scope
- Product differentiation
- Access to financial resources
- Access to distribution and sales channels
- Regulatory measures that may facilitate market entry
- Potential competition
- Countervailing buying power
- Competition pressure from the retail market

382. Nkom stresses that the relevant subject of the assessment is the existence of significant market power and not anti-competitive abuse of market dominance. It is therefore not decisive for the assessment of significant market power whether any market power or dominance is actually misused or not. Although structural indicators are central to the assessment of significant market power, a supplier's behaviour in the market will also be relevant.

3.3 Market shares

3.3.1 Market shares as an indicator of significant market power in general

383. Market shares are the point of departure for assessment of significant market power and the indicator given most weight by ESA³⁷. High and stable market shares over time may indicate significant market power. It is also relevant to look at the providers' relative market shares. If a provider has a stable market share of over 50%, there is a legal presumption of significant market power. However, individual dominance will normally be found for a provider with a market share of over 40%³⁸.

384. In paragraph 76 of the Guidelines, ESA writes:

“According to established case-law, very large market shares - in excess of 50 % - are in themselves, save in exceptional circumstances, evidence of the existence of a dominant position. An undertaking with a large market share may be presumed to have SMP, that is to be in a dominant position, if its market share has remained stable over time. The fact that an undertaking with a significant position on the market is gradually losing market share may well indicate that the market is becoming more competitive, but it does not preclude a finding of significant market power.”

³⁷ Paragraph 76 of the Guidelines.

³⁸ Paragraph 76 of the Guidelines

385. When using market shares as an indicator of significant market power, it is necessary to consider which measurement parameters are most relevant for the purpose. ESA writes in clause 78 of the Guidelines:

“The criteria to be used to measure the market share of the undertaking(s) concerned will depend on the characteristics of the relevant market. It is for NRAs to decide which are the criteria most appropriate for measuring market presence.”

386. It follows from this that there are characteristics of the relevant market that will be decisive for choice of measures of market share and that it is up to the national regulatory authority to decide which measure is best suited for the purpose. Market shares can be measured by number of subscriptions, sales revenue, number of accesses, etc.

387. Below, Nkom describes and analyses the developments in market shares in Market 3a and Market 3b, with a focus on ascertaining the possible existence of significant market power.

388. In Section 2.4 above, Nkom has concluded that the markets for wholesale central and local access include both external and internal sales. In this context, “external sales” means sales to external wholesale customers, while “internal sales” are broadband accesses offered to the provider’s own service provider operations. With the exception of the market shares for the externally sold accesses, the market share figures in the following include both internal sales at Telenor and rival vertically integrated providers.

389. Nkom’s analysis of market shares at the wholesale level includes market shares based on both the number of accesses and sales revenue. Since Market 3a and Market 3b are closely tied to the physical infrastructure in the access network, and the appropriate accesses are used as a basis for offering standardised broadband access, Nkom regards market share based on the number of accesses to be the best starting point for assessment of significant market power. Since there are no actual revenue figures for internal sales, it has been necessary to base the market shares by sales revenue on estimates. This entails greater uncertainty regarding market share based on sales revenue, but Nkom believes that these estimates can nevertheless provide useful additional information. At the same time, the uncertainty associated with market shares based on sales revenue is another argument in favour of the view that the main emphasis should be placed on market shares based on the number of accesses.

390. As Section 2.2.5 shows, in the electronic communication statistics Nkom does not distinguish between high-quality and standardised broadband access for businesses. Nkom does not, therefore, have precise information about the number of subscriptions or sales revenue for standard broadband access in the business market. Even though some of the broadband subscriptions reported in the business market will be deemed to be high-quality, dedicated Internet access, Nkom assumes that a large proportion of the broadband subscriptions in the business market can be considered to be standard broadband access. Moreover, the number of broadband accesses in the private market far exceeds the business

market. Nkom therefore uses the number of broadband subscriptions reported in the electronic communication statistics as the basis for the calculation of market shares in Markets 3a and 3b.

3.3.2 Market 3a

3.3.2.1 Market size and development

391. On the demand side, Market 3a consists of 45 providers which purchase local access to Telenor's copper network. These external access buyers offer standardised private and business products in the end user market. Most of these providers are relatively small and operate within their geographical area, but there are also some large nationwide providers.

392. On the supply side, Telenor and other network owners are included in the copper and fibre accesses which are used for standardised broadband subscriptions in the end user market. Other network owners than Telenor are potential wholesale providers in Market 3a. This entails that Telenor's own copper and fibre accesses, as well as other network owners' fibre accesses used in the end-user market, are included in Market 3a. Reference is made to Section 2.4.3 for a further description of Market 3a.

393. Figure 37 shows the total number of accesses in Market 3a and the distribution between internal and external sales in the period from 2014 to 2017. The total number of accesses included in Market 3a has increased from approximately 1,320,000 at the end of 2014, to approximately 1,490,000 at the end of 2017. The ratio of internally-sold accesses, i.e. the number of broadband accesses in the copper and fibre networks offered to their own end-user activity, increased from 81.6% of the total sales in Market 3a at the end of 2014, to 88.9% at the end of 2017. External sales, i.e. the sale of broadband accesses via copper and fibre networks to external wholesale customers, have thereby decreased from 18.4% to 11.1% during the same period.

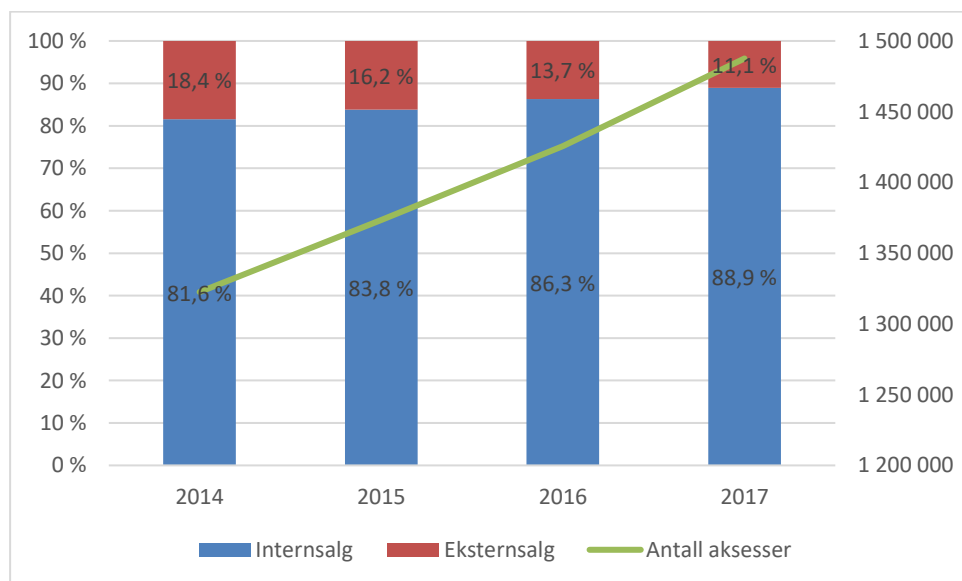

Figure 36: Total number of accesses and distribution between internal and external sales in

Market 3a. (Source: Reported data from Telenor and Nkom’s electronic communication statistics for 2017.)

Internal sales

394. Since most of the sales in the wholesale market for access at local level are internal, there are many common features in the development of the corresponding segment of the end-user market (total sales) and the internal sales.

395. Figure 38 shows that there has been an increase in total internal sales of 23% in the period from the end of 2014 to the end of 2017, i.e. approximately 240,000 accesses. The increase in the ratio of internal sales is related to how the number of internally sold fibre accesses has increased by approximately 347,000, and the fact that access buyers purchase significantly less fibre than copper. In the same period the number of internal, copper-based accesses fell by approximately 103,000. The changes entail that fibre accesses accounted for 70% of internal sales at the end of 2017, compared to 54% at the end of 2014. The ratio of internal, copper-based accesses has thereby declined from 46% to 30% in the same period.

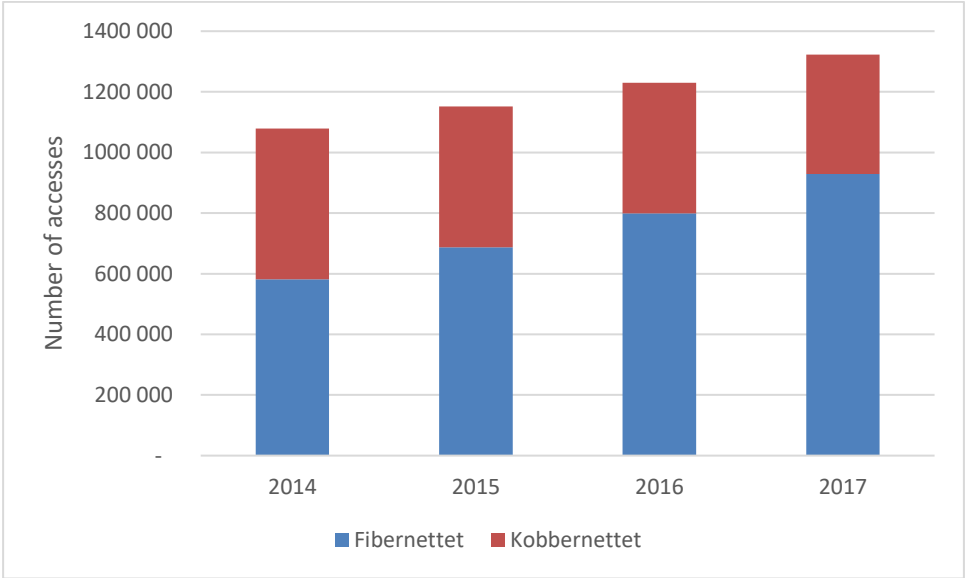

Figure 37: Internal sales measured by number of accesses distributed on technology in Market 3a. (Source: Reported data from Telenor and Nkom’s electronic communication statistics for 2017.)

396. In accordance with Nkom’s decision of 20 January 2014 in the former Market 4, Telenor has an access obligation concerning its fibre-based point-to-point network. This network constitutes only a small part of Telenor’s fibre-based access network. So far, no access buyers have taken advantage of the access obligation concerning Telenor’s point-to-point network in the former Market 4. In overall terms, the increase in the ratio of fibre accesses thereby means that the ratio of internal sales has diminished.

397. The increases in the ratios of fibre accesses and internal sales are also related to how companies competing with Telenor have established new fibre networks during the past ten years and that these companies have increased their market shares. The competing fibre networks almost exclusively offer access to their own vertically integrated service provider. Their increase in market share in the end-user market thereby contributes to increasing the ratio of internal sales. The fact that these providers almost exclusively offer services to their own end-user activity furthermore entails that these establishments have only had a direct impact on the competitive conditions in the associated end-user market.

398. Telenor has expressed how they will intensify their focus on fibre-based access networks and state that their objective is to achieve a market share of around 40%³⁹ of the fibre-based part of the end-user market for standardised broadband access. At the same time, Telenor’s competitors continue to establish new fibre networks in parts of the country and are continuing to grow. There is therefore uncertainty relating to how the establishment of new fibre networks will affect the ratio of internal sales going forward.

External sales

399. As Figure 37 shows, at the end of 2017 external sales accounted for only 11% of the total sales in the wholesale market for access at local level. The development in external sales during the period from the end of 2014 to the end of 2017 is shown in Figure 39. During this period, external sales declined by 32%, i.e. by approximately 79,000 accesses. As stated above, the decline is related to the transition from copper-based accesses to other platforms such as fibre. It is uncertain whether this trend will continue at the same pace as in recent years. Upgrading the copper network in order to be able to offer end-customers higher speeds would make copper-based products more attractive to the end users and would thereby influence this development.

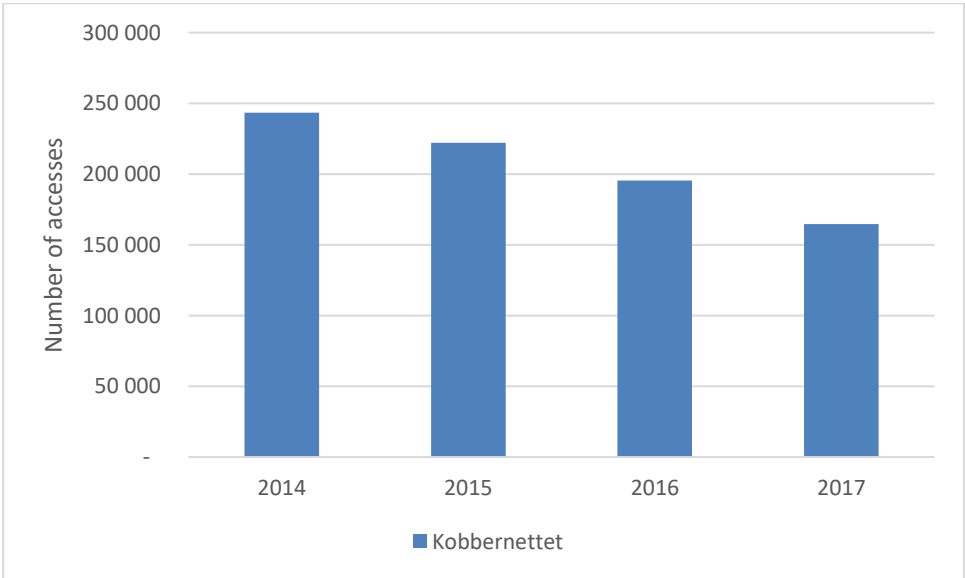

³⁹ <https://www.telenor.com/investors/presentations/2017/capital-markets-day-2017/>

Figure 38: External sales in the copper network in Market 3a. (Source: reported data from Telenor.)

400. Telenor accounts for close to 100% of the external sales in Market 3a. Telenor’s external sales exclusively comprise copper-based LLUB since, so far, no wholesale customers purchase LLUB fibre access from Telenor. There is some external sale of fibre networks that are not owned by Telenor, but the extent of this is of little significance in this respect.

401. As Figure 40 shows, NextGenTel is by far the largest external access purchaser of copper-based LLUB access. At the end of 2017 NextGenTel accounted for 41.8% of the externally sold accesses purchased from Telenor. Broadnet is the second-largest external access buyer in this market, with 31% of the externally sold copper accesses at the same time, while Eidsiva broadband is the third-largest access buyer, with a ratio of 6.2%. The remaining operators each have a share of around 5% or less of the externally sold accesses.

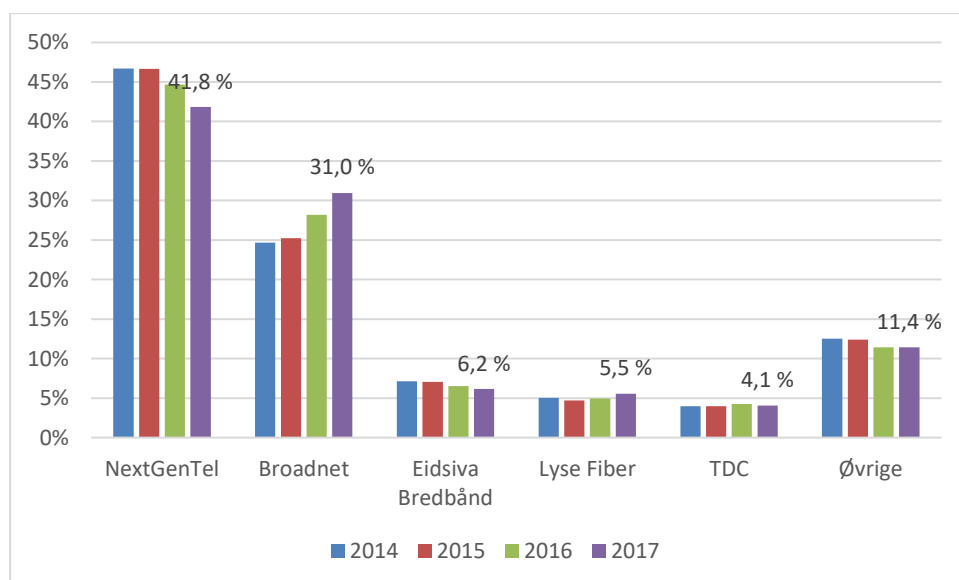

Figure 39: Overview of external access buyers of copper-based LLUB accesses at the end of 2017. (Source: reported data from Telenor.)

3.3.2.2 Market shares based on number of accesses

402. Telenor’s market share in Market 3a is calculated as the sum of Telenor’s copper- and fibre-based broadband subscriptions in the end-user market for standardised broadband access (internal sales) and wholesales sale in Market 3a (external sales), divided by the total number of corresponding subscriptions in the end-user market, i.e. subscriptions based on copper and fibre accesses. For other providers with their own access networks, the market share is calculated on the basis of the number of copper- and fibre-based subscriptions in the end-user market, less the number of subscriptions that are based on the purchase of access from Telenor in Market 3a and Market 3b.

403. Figure 41 shows the development in market shares for Market 3a, based on the number of accesses. The figure shows that at the end of 2017, Telenor had a market share of

53.5%, when both internal and external sales are included. The equivalent market share was 66.3% at the end of 2014, which entails a reduction in market share of 12.8 percentage points.

404. Lyse Fiber saw growth exceeding 2.6 percentage points in the same period and had a total market share of 16.1% at the end of 2017. Get had growth of 2.6 percentage points and a market share of 5.1% at the same time. The overall market share of other operators in the market increased gradually, and stood at 25.3% at the end of 2017.

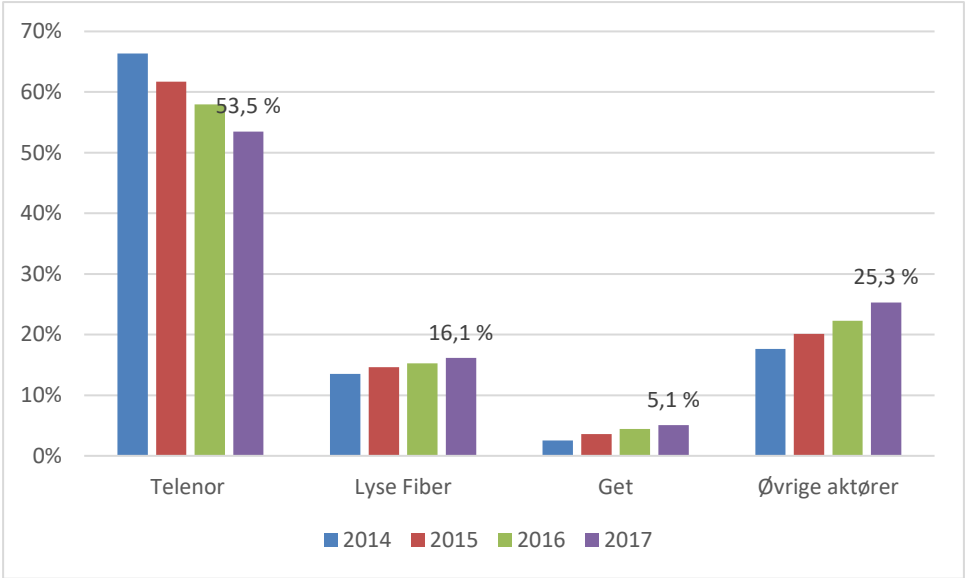

Figure 40: Development in market shares for Market 3a, based on the number of accesses. (Source: Reported data from Telenor and Nkom’s electronic communication statistics for 2017.)

405. Figure 41 shows that Telenor’s market share declined in the period. At the same time, Telenor’s market share is still considerably higher than other operators in the market and still at a level that leads to the assumption of significant market power. Increased market shares for competitors such as Lyse Fiber and Get indicate that the competition pressure in the end-user market has increased. At the same time, Telenor’s increased focus on fibre and a possible upgrading of the copper network might contribute to Telenor increasingly maintaining its market shares going forward.

Externally sold accesses

406. Telenor virtually has a 100% market share measured by externally sold accesses. This total dominance is due to the fact that, with a few exceptions in limited areas, Telenor is the sole provider of external access. Telenor is also the only provider required to give access to copper- and fibre-based access networks. This situation has been stable since the last analysis.

407. There are several providers with their own fibre access networks that could potentially offer external access in the relevant wholesale market. However, Nkom does not have any indications of increasing interest among the providers in this market to sell external access.

408. In the context of how Telenor is the only provider with a nationwide access network, Nkom expects that access to Telenor's access network will continue to be an important input factor for external access buyers within the time perspective of the analysis.

3.3.2.3 Market shares based on revenue

409. Telenor's market share in Market 3a based on revenue is calculated as the sum of Telenor's end-user revenue for copper- and fibre-based broadband accesses and estimated end-user revenue, based on external wholesale revenue, divided by the corresponding total revenue in the end-user market. The market share of other operators with their own networks is calculated as the provider's end-user revenue based on its own infrastructure, divided by total revenue in the end-user market for copper- and fibre-based broadband accesses. With regard to operators that base their broadband offering in the end-user market on a combination of their own access network and wholesale purchase from Telenor, the market share in Market 3a is calculated solely on the basis of the proportion of the revenue that is associated with its own access network.

410. Figure 42 shows that Telenor's market share based on revenue in 2017 was an estimated 52.3% in Market 3a, compared with 63.6% in 2014. Telenor's market share based on revenue is thus reduced by over 11 percentage points. Lyse Fiber had a market share of 14.4% in 2017, and has thereby seen growth of almost two percentage points in the same period. Get increased its market share by almost two percentage points during the period from 2014 to 2017, and had a market share of 3.6% at the end of 2017. Other providers in Market 3a had a total market share of 29.7% in 2017, which is growth of eight percentage points from 2014. Figure 42 shows that Telenor still has a market share based on revenue that is significantly higher than the other operators in the market. The reduction in market shares for Telenor indicates increased competitive pressures in the end-user market.

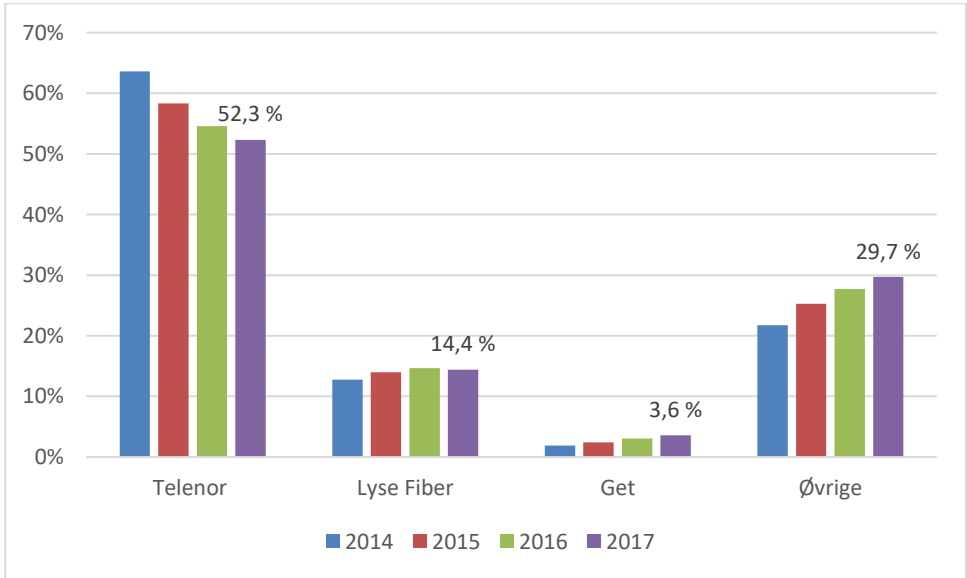

Figure 41: Development in market shares for Market 3a, based on revenue. (Source: Reported data from Telenor and Nkom's electronic communication statistics for 2017.)

411. As shown by Figures 41 and 42, the market share distribution does not deviate particularly according to whether it is based on number of accesses or revenue.

3.3.2.4 Market shares based on all platforms for standardised broadband access.

412. In Section 2.4.3, Nkom concluded that wholesale access to HFC networks and fixed radio access are not included in Market 3a. On the calculation of market shares in Market 3a, cf. Sections 3.3.2.2 and 3.3.2.3 above, HFC networks and fixed radio access are therefore not included. Through the associated end-user market, competitive pressure based on these platforms might constitute indirect competitive pressure in the relevant market, cf. also Section 3.17 below. Below, Nkom will examine what the market shares would be, in hypothetical terms, if these two access forms had been part of the relevant market.

413. Figure 43 shows the hypothetical development in market shares based on the number of accesses if all fixed broadband accesses were included. The figure shows that Telenor's market share would have fallen from 59% at the end of 2014 to 50.2% at the end of 2017. Telenor's market share on the inclusion of such broadband accesses would thereby be 3.3 percentage points lower than it is in Market 3a. Nkom cannot see any evidence that the development in market shares would be particularly different on any such market share calculation, compared with what would apply in the relevant market. Nkom concludes that a market share assessment based on the number of accesses for all platforms does not give evidence for any other conclusions with regard to the assessment of significant market power than those shown above in connection with the market shares in Market 3a.

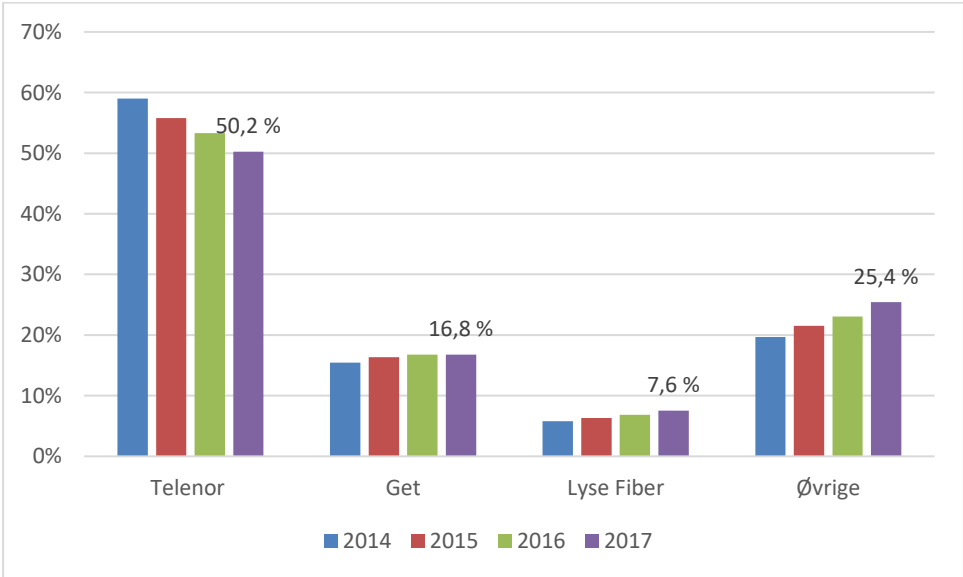

Figure 42: Development in market shares which include fixed broadband accesses via copper, fibre and HFC networks, and fixed radio access, based on the number of accesses. (Source: Reported data from Telenor and Nkom's electronic communication statistics for 2017.)

414. Nkom has also assessed whether market shares for all platforms can provide a basis for diverging conclusions on measuring revenue. Figure 44 shows that Telenor's market share

would then have been 49.2% at the end of 2017. In this case too, the market share assessment shows a picture and a development that generally coincide with what is described for the relevant market.

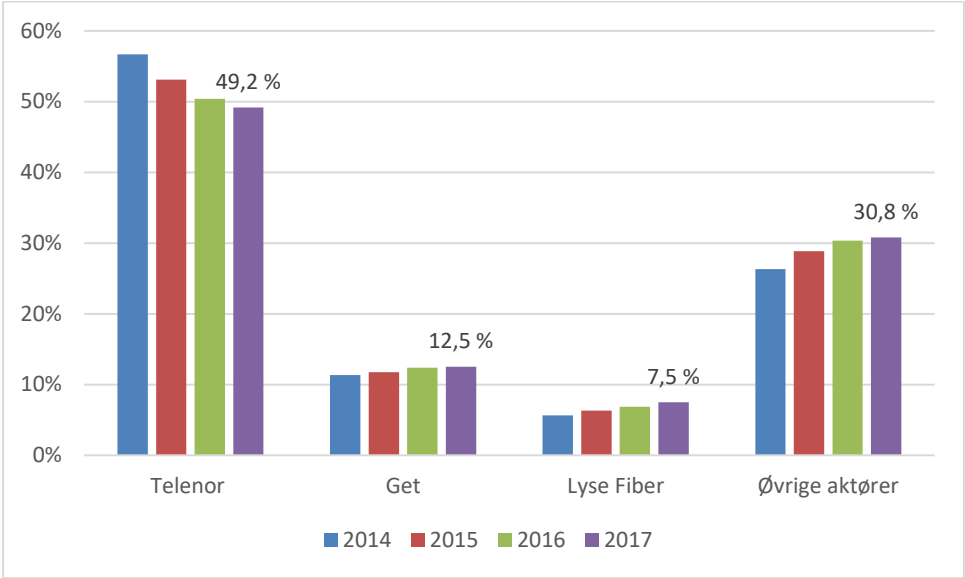

Figure 43: Development in market shares including fixed broadband accesses via copper, fibre and HFC networks, and fixed radio access, based on revenue. (Source: Reported data from Telenor and Nkom’s electronic communication statistics for 2017.)

3.3.2.5 Overall assessment and conclusion

415. At the end of 2017, Telenor had a market share in Market 3a of 53.5%, based on the number of accesses. Telenor’s market share based on revenue was 52.3% in 2017. Nkom believes that market shares based on the number of accesses is the best starting point for as assessment of significant market power in Market 3a. There is furthermore greater uncertainty associated with the calculation of market shares based on revenue than on the number of accesses. Telenor’s market share exceeds 50% and is thereby at a level that indicates the assumption of significant market power. For comparison, Lyse Fiber had a market share of 16.1% based on the number of accesses, and 14.4% based on revenue.

416. Telenor’s high market share is to a great extent based on the company’s ownership of the nationwide, copper-based access network. However, the expansion of fibre-based access networks in recent years has resulted in a declining market share for Telenor. In isolated terms, the continued expansion of fibre-based networks indicates that the growth of alternative providers will continue.

417. At the same time, the possible upgrading of the copper network in order to be able to offer products with higher speeds might make copper-based products more attractive to end-users going forward. Upgrading of the copper network in some areas, combined with Telenor’s increased focus on fibre, would thus be able to contribute to a less significant reduction of Telenor’s market shares in the coming years. Nkom therefore expects that Telenor will be able

to maintain a market share exceeding 50% at wholesale level within the time perspective of the analysis.

418. In terms of market shares measured by external sales, Telenor has a stable market share of almost 100%. This very high, stable market share is attributable to the fact that Telenor is the only provider that has an obligation to offer access to both copper-based and fibre-based access networks. There is no evidence to suggest that this position will change significantly.

419. In Nkom's assessment, an overall assessment of the criterion of market shares gives a clear indication that Telenor has significant market power in this relevant market.

3.3.3 Market 3b

3.3.3.1 Market size and development

420. On the demand side, Market 3b consists of almost 20 providers which purchase centralised access to Telenor's copper network. One of these providers also purchases centralised access to Telenor's fibre network. These external access buyers offer standardised private and business products in the end-user market. Most of these providers are relatively small and operate within their geographical area, but there are also some large nationwide providers.

421. On the supply side, the end-user market includes Telenor's and other network owners' copper, fibre, HFC and fixed radio accesses, which are used for standardised broadband subscriptions in the end-user market. Other network owners than Telenor are potential wholesale providers in Market 3b. Wholesale customers that purchase local access from Telenor in Market 3a are also potential wholesale providers in Market 3b. This entails that Telenor's own copper, fibre, HFC and fixed radio accesses, as well as other network owners' fibre, HFC and fixed radio accesses offered in the end-user market, are included in Market 3b. Reference is made to Section 2.4.5 for a further description of Market 3b.

422. Figure 45 shows the total number of accesses and the distribution between internal and external sales in Market 3b for the period from 2014 to 2017. At the end of 2017, internal sales, i.e. the number of broadband accesses via the copper, fibre, HFC and fixed radio access networks offered to own end-user activity, accounted for approximately 97% of total sales in Market 3b. Internal sales in Market 3b also include copper-based LLUB accesses which wholesale customers buy in Market 3a and offer to their own customers in the end-user market. External sales, i.e. sales of broadband accesses via copper and fibre networks to external wholesale customers, have been relatively stable at approximately 3% of the total sales in Market 3b during the period from 2014 to 2017. The ratio between internal and external sales has thus also been relatively stable during this period, despite growth in the total number of accesses.

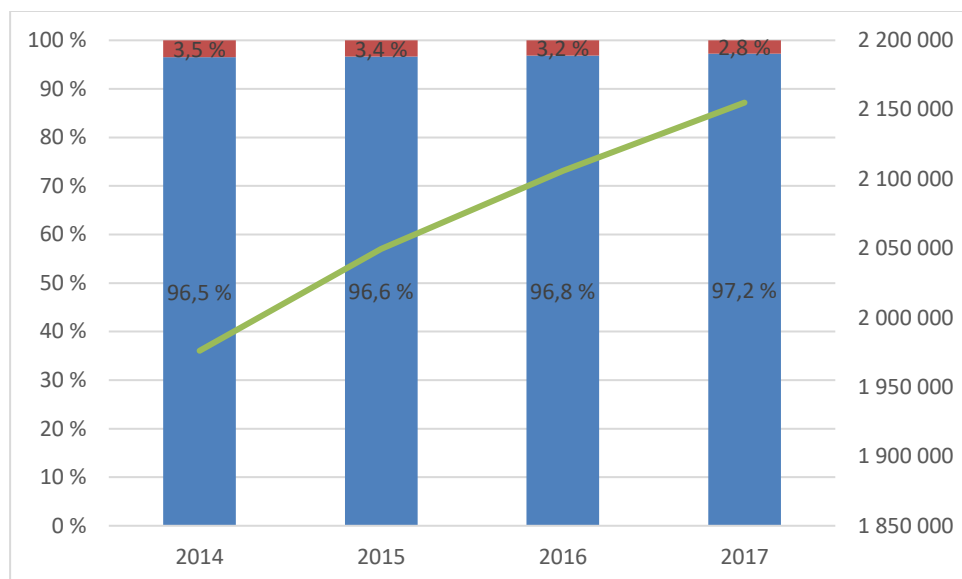

Figure 44: Total number of accesses and distribution between internal and external sales in Market 3b. (Source: Reported data from Telenor and Nkom's electronic communication statistics for 2017.)

Internal sales

423. Since most of the sales in the wholesale market for access at centralised level are internal, there are many common features in the development of the corresponding segment of the end-user market (total sales) and the internal sales.

424. During the period from the end of 2014 up to the end of 2017, there was an increase in total internal sales of 189,000 accesses, i.e. 9.8%, cf. Figure 46. The change is mainly due to an increase by 211,000 fibre accesses, which gives an increase in the ratio of fibre accesses from 30.5% at the end of 2014 to 43.9% at the end of 2017. The number of accesses based on HFC networks increased by 25,000 in the same period and the ratio is relatively stable at around 30%. The number of copper-based accesses saw a decline of 105,000, which constitutes a reduction of 10.9 percentage points, from 35.2% to 24.3%, in the same period.

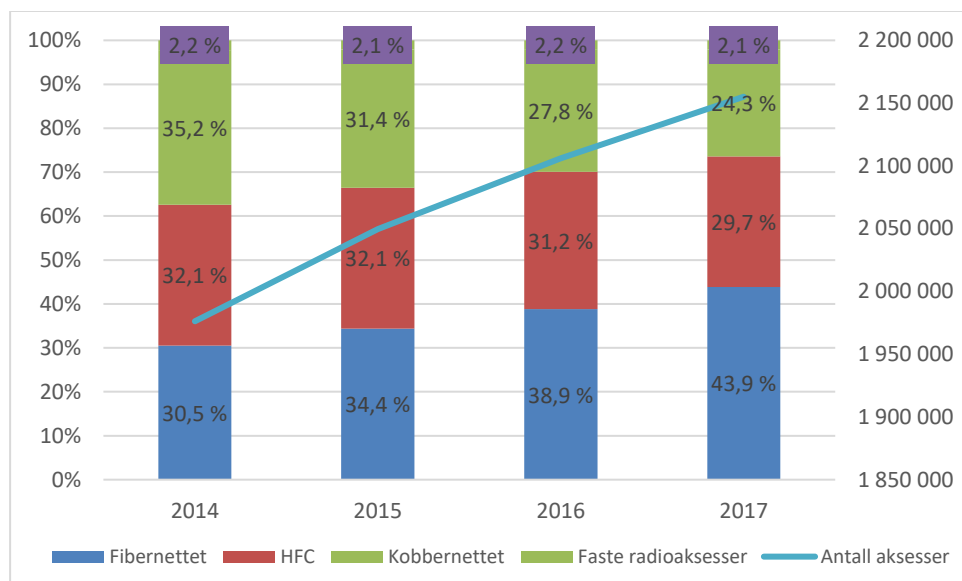

Figure 45: Internal sales distributed by technology in Market 3b. (Source: Reported data from Telenor and Nkom's electronic communication statistics for 2017.)

External sales

425. As Figure 45 shows, at the end of 2017 external sales accounted for approximately 3% of the total sales in the wholesale market for access at centralised level. External wholesale sales in this market only occur in the copper- and fibre-based access networks. The development in external sales during the period from the end of 2014 to the end of 2017 is shown in Figure 47. Overall, there was a decline of approximately 9,000 accesses for external sales, i.e. 13.1%, during this period. The decrease is related to the sale of fewer copper accesses.

426. Telenor's access obligation for fibre-based broadband access has meant that the reduction in external sales of copper accesses has to some extent been compensated by external sales of fibre-based accesses. Depending on which access products are offered, and on which terms, Nkom expects that the external sales of fibre-based accesses will increase further in the next few years, in parallel with Telenor's increased cover in its fibre network. Furthermore, Nkom believes that a possible upgrading of the copper network in order to be able to offer higher speeds would make copper-based products in this market more attractive to the end-users.

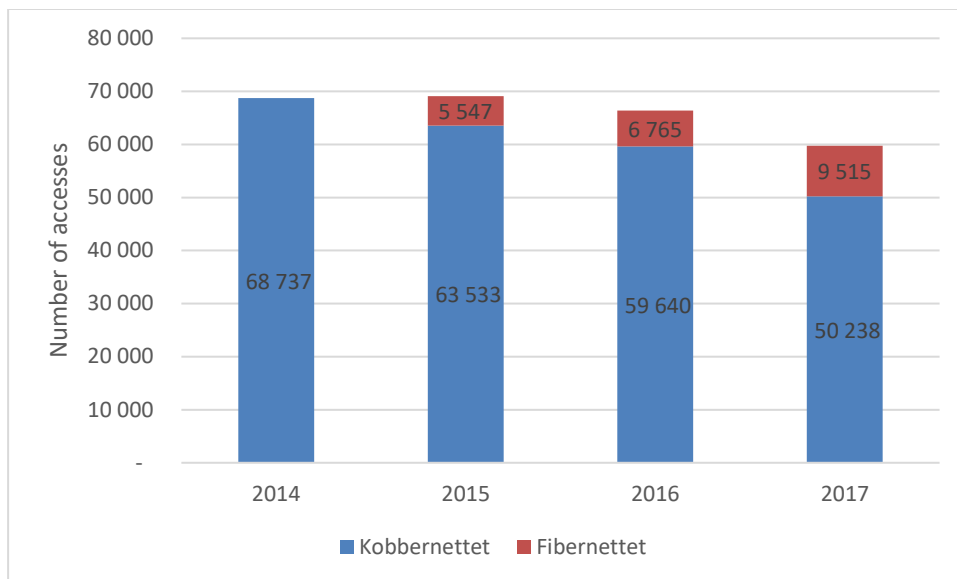

Figure 46: External sales distributed by technology in Market 3b. (Source: reported data from Telenor.)

427. Telenor accounts for close to 100% of the external sales in Market 3b. There is also some external sale in fibre networks that are not owned by Telenor, but the extent of this is of little significance in this context.

428. As Figure 48 shows, NextGenTel is by far the largest external access buyer in Market 3b and at the end of 2017 accounted for 59% of the accesses purchased by external access buyers, distributed on copper-based products (Jara DSL) at 73% and fibre-based products (VULA) at 27%. At the same time, the shares of Broadnet and TDC were 30% and approximately 8%, respectively, while the remaining 3% is distributed among the other operators on the demand side.

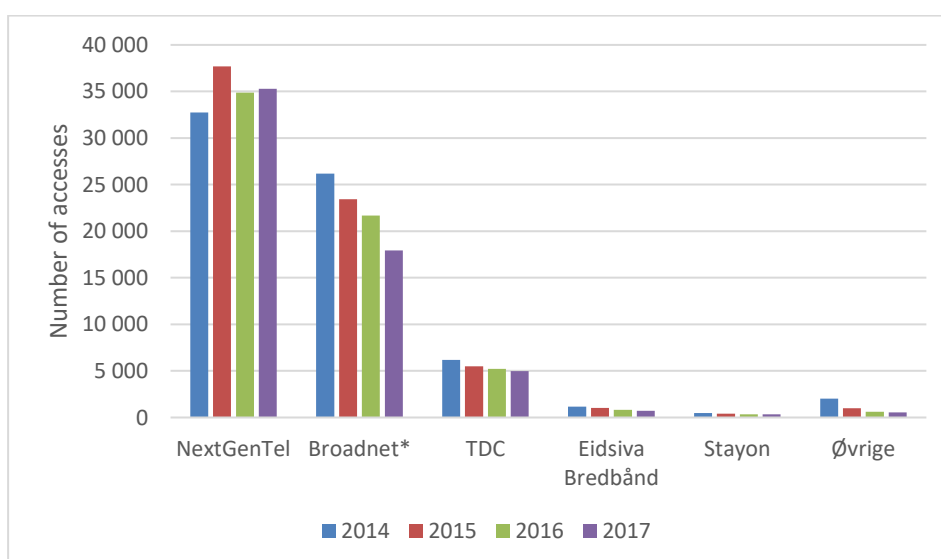

Figure 47: Overview of external access buyers in Market 3b as of the end of 2017. (Source: Data received from Telenor in connection with this market analysis.)

3.3.3.2 Market shares based on number of accesses

429. Telenor's market share in Market 3b is calculated as the sum of Telenor's own broadband subscriptions in the end-user market for standardised broadband access (internal sales) and external wholesale sales in Market 3b, divided by the total number of corresponding subscriptions in the end-user market. Other operators' market shares in Market 3b are calculated as the sum of the operators' own broadband subscriptions in the end-user market for the technologies included in Market 3b, less any purchase of Telenor's wholesale products in Market 3b, divided by the total number of corresponding subscriptions in the end-user market.

430. Figure 49 shows the development in market shares for Market 3b, based on the number of accesses. The figure shows that at the end of 2017 Telenor had a market share of 42.6%. The equivalent market share was 46.7% at the end of 2014, which entails a reduction of 4.1 percentage points. Telenor's market share is thereby at a level where significant market power would normally be found. In the light of recent years' development, as well as Telenor's declared focus on fibre and potential upgrading of the copper network, Nkom expects that Telenor's market share will remain in excess of 40% within the timeframe of the analysis.

431. The market shares of Get and Lyse Fiber have increased gradually during the same period and were 16.8% and 8%, respectively, at the end of 2017. The overall market share of other operators increased by approximately 6 percentage points to 25% at the end of 2017.

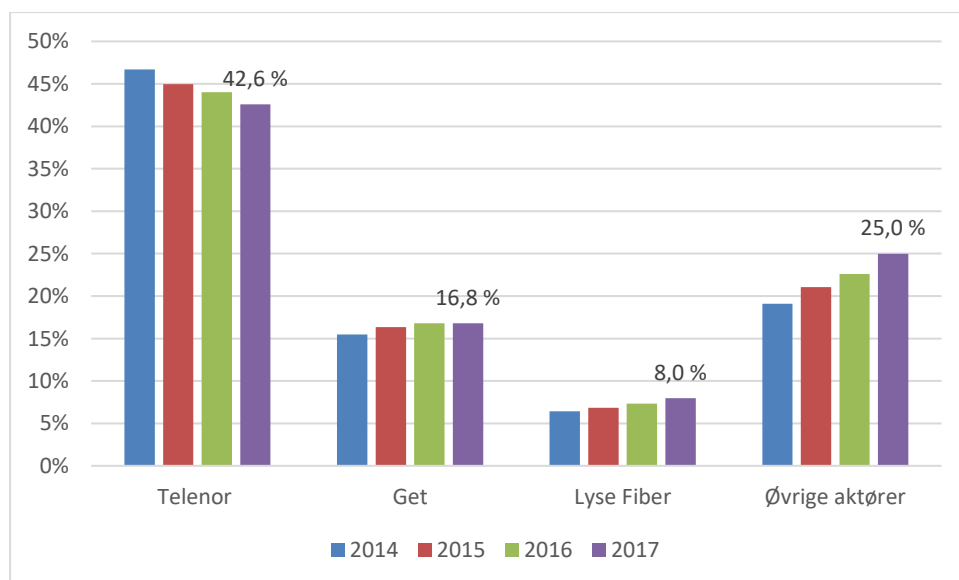

Figure 48: Development in market shares for Market 3b, based on the number of accesses. (Source: Reported data from Telenor and Nkom's electronic communication statistics for 2017.)

432. Figure 49 shows that Telenor's market share declined during the period. This decrease is lower than what applies to Market 3a, based on the same measurement parameter. Even though Telenor's market share in Market 3b is lower than in Market 3a, in this case too,

Telenor has a significantly higher market share than other operators in the market. Increased market shares for Get and Lyse Fiber indicate increased competitive pressure in the end-user market. Nkom assumes that alternative providers in parts of the country will continue to develop fibre-based networks during the period assessed in the analysis. However, Nkom cannot see any evidence that this competitive pressure has a particularly disciplining effect on Telenor's scope for manoeuvre in the relevant wholesale market. At the same time, Telenor's increased focus on fibre and possible upgrading of the copper network might contribute to Telenor increasingly maintaining its market shares going forward.

Externally sold accesses

433. Telenor has virtually a 100% market share, measured by externally sold accesses. This total dominance is due to the fact that, with a few exceptions in limited areas, in real terms Telenor is the sole provider of external access. Telenor is also the only provider required to give access to copper- and fibre-based access networks. This situation has been stable since the previous analysis.

434. There are several providers with their own fibre access networks that could potentially offer external access in the relevant wholesale market. As stated below in Section 3.15, in 2016 the working group for fibre-based broadband access in Broadband Forum prepared a framework for access to fibre networks that have received public subsidies. It emerged during the work that providers who received such support considered it most relevant to offer bitstream access, and the framework is designed for such access. As the aforementioned section also shows below, however, the number of accesses which are actually relevant for access buyers to buy access to is relatively modest.

435. Nkom assumes that Telenor's market share measured by externally sold accesses might decline somewhat in the period assessed by the analysis, but considers it likely that the market share will remain very high. Viewed in the context of how Telenor is the only provider with a nationwide access network, Nkom expects that access to broadband access in Telenor's copper network and fibre network will continue to be an important input factor for external access buyers within the timeframe of the analysis.

3.3.3.3 Market shares based on revenue

436. Telenor's market share in Market 3b based on revenue is calculated as the sum of Telenor's revenue in the end-user market for standardised broadband access (internal sales) and external wholesale sales in Market 3b, divided by the corresponding total revenue in the end-user market. The market share of other operators with their own network is calculated as the provider's end-user revenue based on its own infrastructure, divided by total revenue in the end-user market for standardised broadband accesses. With regard to operators that base their broadband offering in the end-user market on a combination of their own access network and wholesale purchase from Telenor, and possibly solely on wholesale purchase from Telenor, the market share in Market 3b is calculated solely on the basis of the proportion of the

revenue which concerns their own access network or wholesale purchase of LLUB from Telenor.

437. Figure 50 shows that Telenor's market share based on revenue in 2017 was an estimated 41.5% in Market 3b, compared with 44.4% in 2014. This gives a reduction in market shares of 2.9 percentage points from 2014 to 2017, despite weak growth during the past year. For comparison, Get's market share increased gradually to 12.5% in 2017. Lyse Fiber had a market share of 7.9% in 2017. Figure 50 shows that Telenor still has a market share that is significantly higher than the other operators in the market. The growth in the market shares of Get and Lyse Fiber also indicate increased competitive pressure in the end-user market. As described above, however, there is little evidence that this competitive pressure has a particularly disciplining effect on Telenor's scope for manoeuvre in this wholesale market.

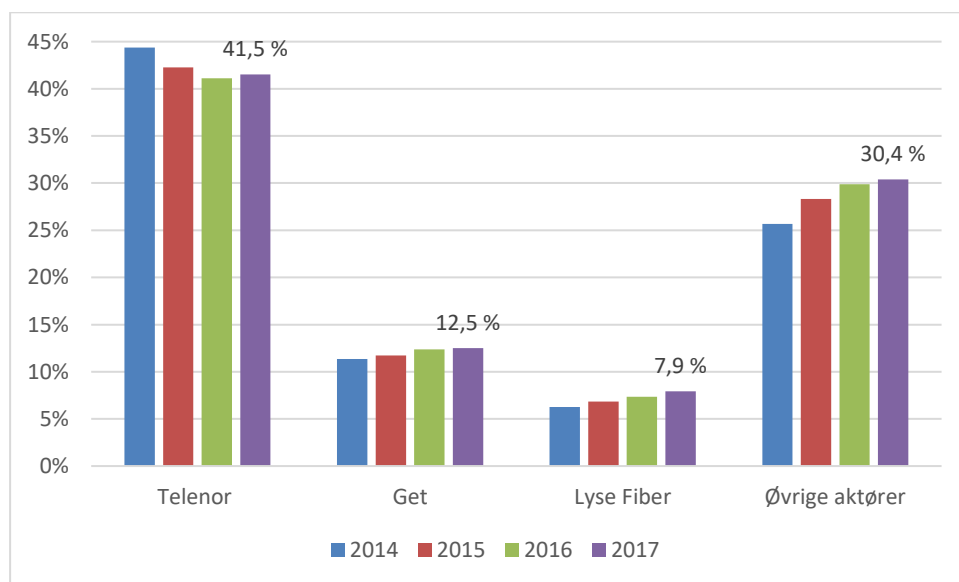

Figure 49: Development in market shares for Market 3b, based on revenue. (Source: Reported data from Telenor and Nkom's electronic communication statistics for 2017.)

438. Comparison of Figures 49 and 50 also shows that the market share distribution in Market 3b, based on the number of accesses and revenue, respectively, deviates slightly. As Section 3.3.1 shows, Nkom considers market shares based on number of accesses to be the best starting point for the assessment of significant market power.

3.3.3.4 Overall assessment and conclusion

439. At the end of 2017, Telenor had a market share in Market 3b of 42.6%, based on the number of subscriptions, which is a decrease from 46.7% at the end of 2014. Similarly, the market share based on revenue fell from an estimated 44.4% in 2014 to 41.5% in 2017, despite weak growth during the past year. Nkom believes that market shares based on number of accesses is the best starting point for the assessment of significant market power in Market 3b. There is also greater uncertainty associated with the calculation of market shares based on revenue than on the number of subscriptions. Telenor's market share based on the

number of access exceeds 40% and is thereby at a level at which significant market power would normally be found. For comparison, Get had a total market share of 16.8%, based on the number of subscriptions, and 12.5% based on revenue.

440. Telenor's high market share is based to a great extent on the company's ownership of the nationwide, copper-based access network. However, the expansion of fibre-based access networks in recent years has resulted in a declining market share for Telenor. In isolated terms, the continued expansion of fibre-based networks indicates that the growth of alternative providers will continue. At the same time, Telenor has recently demonstrated increased focus on fibre, and the company has expressed the ambition to achieve a market share close to 40% in the fibre-based part of the end-user market.

441. At the same time, the possible upgrading of the copper network in order to be able to offer products with higher speeds might make copper-based products more attractive to end-users going forward. Upgrading of the copper network in some areas, combined with Telenor's increased focus on fibre, would thus be able to contribute to a less significant reduction of Telenor's market shares in the coming years. Nkom therefore expects that Telenor will be able to maintain a market share, based on the number of subscriptions, which exceeds 40% within the timeframe of the analysis.

442. In terms of market shares measured by external sales, Telenor has a stable market share of almost 100%. This very high, stable market share is attributable to the fact that Telenor is the only provider that has an obligation to offer access to both copper-based and fibre-based access networks. There is no evidence to suggest that this position will change significantly.

443. In Nkom's assessment, an overall assessment of the criterion of market shares indicates that Telenor has significant market power in the relevant market.

3.4 The size of the companies

444. The criterion "size of the companies" refers to potential benefits that may arise through a business's relative size compared with its competitors and the extent to which any such benefit can be expected to last in the period assessed in this analysis. Advantages linked to the size of the company may be manifested in areas such as economies of scale and economies of scope, access to financial resources, procurements, distribution, marketing and partnership⁴⁰. These kinds of advantages may affect how the company acts in the relevant market, even if the advantages manifest themselves outside the market being analysed.

445. A company's size can be assessed on the basis of parameters such as sales revenue, number of employees, product range and access to infrastructure.

⁴⁰ The criteria economies of scale and economies of scope, and access to financial resources, will be assessed separately below.

3.4.1 Market 3a and Market 3b

446. Telenor is by far the largest provider in the Norwegian electronic communications market as a whole and has been for a long time. The company's turnover in 2017 was NOK 22.4 billion, out of a combined electronic communications turnover of NOK 45.5 billion. By comparison, the next-largest two providers had turnover of NOK 6.3 billion (Telia Norge) and NOK 2.7 billion (Get). Large companies are generally less vulnerable to economic fluctuations and changes in the market, given that the company is financially robust. Telenor has reported good profitability for its operations in Norway for many years and must be regarded as financially robust⁴¹.

447. Telenor also has the largest network in Norway for production of electronic communications services and has the widest range of services of all the providers in Norway. The company has a nationwide copper-based access network, as well as extensive HFC and fibre-based access networks. In addition, Telenor has a nationwide mobile network, a nationwide trunk network and a nationwide broadcasting network. Telenor is also the leading provider of broadband, mobile telephony, fixed telephony and TV services. In Nkom's opinion, the breadth of Telenor's networks and ranges provides the company with advantages that its competitors do not have to the same degree, in terms of being able both to make long-term investments and to offer comprehensive solutions to its customers. Telenor's extensive electronic communications infrastructure also means that Telenor's competitors are often dependent on Telenor in several areas, making Telenor an important wholesale supplier, which gives Telenor an advantage in negotiations with its access buyers.

448. As can be seen in table 10 below, Telenor has significantly more employees in Norway than the three next-largest providers. In Nkom's opinion, the difference in the number of employees is capable of giving Telenor an advantage over its competitors, for example in areas such as product development, strategy, sales, operational and support functions, and customer management. However, employees in Norway may work on services delivered in other countries and thus other electronic communications markets than the Norwegian. On the other hand, the electronic communications services delivered in Norway could also be supported by employees in countries other than Norway. The fact that a company also has operations in other geographical markets may also mean the company achieves special knowledge and experience. Overall, Nkom believes it is reasonable to assume that the significant difference in the number of employees in Norway will serve to give Telenor relevant competitive advantages in the relevant markets.

⁴¹ See also Section 3.12 below on access to financial resources.

Company	Number of employees
Telenor Norge AS	4557
Get AS	636
Broadnet	383
NextGenTel	202

Table 10: Number of employees (Source: Nkom's electronic communication statistics for 2017)

449. Telenor is significantly larger than its competitors in terms of parameters such as sales revenue, number of employees, product offering and access to infrastructure. According to Nkom's assessment, this gives the company competitive advantages that appear to support the view that the company has significant market power in Market 3a and Market 3b.

3.5 Price developments

450. Developments in prices over time may reflect the degree of competition, or the degree of potential competition, and provide an indication of whether a provider has market power. Normally, increased competition will give companies incentives to lower prices, as companies generally have to adapt their prices to developments in the market. Generally, frequent price drops in a market will therefore indicate well-functioning competition, while less frequent price changes will often indicate that competition is limited.

451. Developments in wholesale prices affect the competitive opportunities for alternative companies that offer retail services based on Telenor's wholesale products. A fall in wholesale prices will thus, all else being equal, improve the access buyer's ability to compete on price in the retail market.

3.5.1 Market 3a

452. Market 3a is characterised by few players on the supply side, with Telenor as essentially the only provider of access. Sales of access by providers other than Telenor are so limited that they are not capable, in Nkom's opinion, of affecting the access prices in this market. Nkom finds that developments in prices for local access to copper and fibre-based access networks are not driven by competition among providers, but by market regulation.

453. Since Nkom's decision of 20 February 2006, Telenor's copper-based LLU product has been subject to price caps for monthly subscription charges and an obligation of cost orientation for set-up fees and prices for co-location and associated services.

454. In Nkom's decision in Market 4 of 20 January 2014, Nkom concluded that Telenor shall continue to be subject to an obligation to meet all reasonable requests for access to the products full and shared access to the copper access network. This kind of access also includes access to backhaul services, co-location and information and support systems. In the decision a new price cap was set for full access of NOK 85 per month, applicable from 1 March 2014. Since then, the price for full access has been identical to the price cap. Telenor

has had the opportunity to set its prices lower than the regulated price cap, but has chosen to use the regulated price cap in its pricing of copper-based LLU access. In the previous regulatory period, from 2009 to 2014, Telenor was subject to a price cap of NOK 95 per month for full access. In this period too, Telenor's actual LLU prices were identical to the price cap.

455. Prices for setting up an agreement on copper-based LLU, set-up of full and shared access line, management of the agreement on copper-based LLU and switching operators must be cost-oriented, based on the fully allocated historical costs. Cost-oriented prices at the product level means that relevant costs and relevant capital are allocated to the relevant products. Some costs can be linked directly to the products in question, while other costs may apply to several products and must be allocated using relevant distribution formulas or the basis for cost allocations.

456. The cost accounts for the wholesale market for fully unbundled and shared access provided at a fixed location showed a negative product result of NOK 37 million in 2015 and NOK 21 million in 2016. In 2015, the product profitability calculations showed

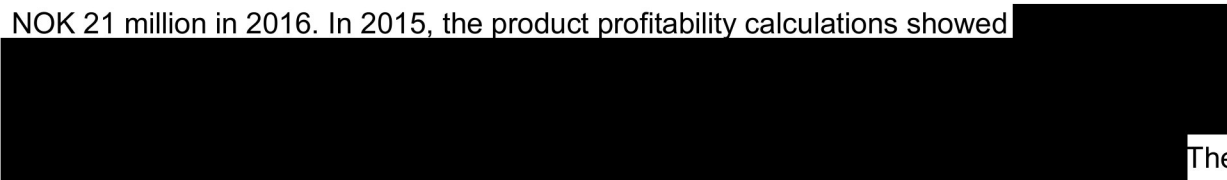
 The unit costs associated with Operator Access have increased in the same period due to declining volumes. To counteract declining volumes and reduced product revenues, Telenor increased the set-up fees for Operator Access full and shared access on 1 March 2014 and 1 June 2015.

457. Through Nkom's decision in Market 4 of 20 January 2014, an obligation was imposed on Telenor to grant access to its fibre-based access network. Nkom concluded that it was neither appropriate nor proportionate to impose price controls on fibre-based LLU. Instead, Telenor was imposed an obligation of non-discrimination and ordered to prepare accounting separation. Nkom was intending to develop a margin squeeze test for fibre-based LLU, but concluded that it was not proportionate since there were so few of these accesses available. The accounting separation for these accesses showed a negative result. Nevertheless, Telenor has not reduced its prices for fibre-based LLU, and Telenor's fibre-based LLU offer has not been used.

458. From an overall perspective, Nkom believes that Telenor's pricing of copper-based LLU, and the fact that Telenor has not adjusted its prices for fibre-based LLU, despite a negative result in its accounting separation figures, may indicate that Telenor does not experience price pressure at the wholesale level and that there are no developments in prices that suggest that Telenor is being disciplined in this market. The criterion "price developments" thus strengthens the presumption that Telenor has significant market power in Market 3a.

3.5.2 Market 3b

459. In the market for wholesale central access, price developments are assessed for central access to copper and fibre-based access networks. Market 3b is characterised by the

presence of few providers, and in reality Telenor is the sole provider. In general, the alternative providers' external sales are so small that they do not, in Nkom's opinion, affect the market prices. As a result, prices in Market 3b for copper and fibre-based access networks are not driven by competition among providers, but by market regulation.

460. In Nkom's decision in Market 5 of 20 January 2014 Telenor was designated a provider with significant market power in the wholesale market for broadband access and had a number of special obligations imposed, including the obligation to provide access for Broadband Access. In addition, price controls based on cost-oriented prices and a requirement to keep corresponding cost accounts were imposed for copper-based Broadband Access. Moreover, for both copper and fibre-based Broadband Access, Telenor was imposed an obligation of non-discrimination with follow-up through accounting separation. In addition, Nkom made a decision on 27 August 2015 on follow-up of the obligation of non-discrimination for fibre-based Broadband Access through the use of margin squeeze tests.

461. Nkom also concluded that the obligation to have cost-oriented prices based on fully allocated historical costs ought generally to be applied at an overarching level for Telenor's prevailing offering of copper-based Broadband Access. This means that Telenor's combined product portfolio within copper-based Broadband Access is subject to the requirement for cost-orientation. Cost-oriented prices at the product level means that relevant costs and relevant capital are allocated to the relevant products. Some costs can be linked directly to the products in question, while other costs may apply to several products and must be allocated using relevant distribution formulas or the basis for cost allocations.

462. Cost accounting for the wholesale market for copper-based Broadband Access revealed product profitability of NOK 1 million in 2016 and NOK -1 million kroner in 2017.

Exempt from public disclosure:

463. After margin squeeze tests had been carried out, Nkom ordered Telenor in the decisions of 9 May 2016, 21 February 2017 and 20 April 2018 to adjust its prices for fibre-based Broadband Access⁴², so that the total wholesale costs were reduced by at least 16.9%, 27.8% and 16% respectively. Telenor appealed all the decisions. On 24 October 2017 the Ministry of Transport and Communications decided the appeal of Nkom's first decision. The Ministry supported Nkom's assessments, but the required price adjustment was amended from 16.9% to 24.7%, as a result of the fact that Nkom had found errors in the figures used in the margin squeeze model.

464. Telenor has reduced its subscription rates on several occasions (e.g. 1 December 2016, 1 April 2017 and 3 January 2018) for some of its fibre-based VULA products since their launch on 20 January 2015. Nkom understands that these price reductions have been made as a result of regulatory pressure.

⁴² See the description of the imposed price adjustment decision in Section 3.6.

465. From an overall perspective, Nkom believes that Telenor's pricing of copper-based and fibre-based access products may indicate that Telenor does not experience price pressure at the wholesale level and that there are no developments in prices that suggest that Telenor is being disciplined in this market. The criterion "price developments" thus strengthens the evidence that Telenor has significant market power in Market 3b.

3.6 Complaints, appeals and supervisory matters

466. Below is a review of some of the complaints, appeals and conflict situations that have arisen during the regulatory period from 2014 related to the former Markets 4 and 5.

3.6.1 SHDSL.bis

467. In September 2013 and in May 2014 respectively, NextGenTel and Broadnet complained that Telenor had denied requests to use SHDSL.bis in Telenor's access network. In its decision dated 10 November 2014, Nkom concluded that NextGenTel's and Broadnet's requests to use SHDSL.bis in Telenor's copper access network were reasonable. Telenor was therefore ordered to meet requests to use SHDSL.bis in Telenor's access network within one month from the decision date.

468. Telenor appealed Nkom's decision. In a decision dated 3 June 2015, the Ministry of Transport and Communications upheld Nkom's conclusion that Telenor must meet the requests to use SHDSL.bis in Telenor's access network.

3.6.2 Telenor's VULA product for fibre

469. NextGenTel contacted Nkom in May 2015 and in June 2015 in conjunction with a number of problems the company was experiencing with the VULA product for fibre that Telenor had launched on 20 January 2015. NextGenTel presented lists of problems related to the product that NextGenTel claimed were unresolved. On the basis of these lists, Nkom asked Telenor to provide an account of what it was doing to resolve the problems. One of the reasons Nkom did this was to assess whether there were grounds to order Telenor to take corrective action pursuant to Section 10-6 of the Electronic Communications Act.

470. In a letter dated 10 October 2015 Nkom concluded that there were no grounds to order Telenor to take corrective action. The reason for this conclusion was that the problems with the VULA product had been resolved on an ongoing basis by Telenor.

3.6.3 Location data in connection with subloop unbundling

471. In June 2015, Broadnet complained about the lack of access to location data from Telenor. The complaint was linked to the fact that Broadnet wanted to test out new technology such as G.fast and VDSL2+ / vectorised VDSL in the copper network. In that connection, Broadnet asked Telenor for access to location data for a large number of subsplitters and cabinets in the copper network. Telenor held that disclosure of such a large volume of data

could be problematic in respect of the Security Act. Telenor wanted to clarify this aspect of the case with the Norwegian National Security Authority (NSM). The parties agreed to use a more limited area as a pilot for the disclosure of location data (the Grorud exchange). In autumn 2015, the parties had a dialogue about what data was necessary for Broadnet to be able to make use of subloop unbundling.

472. At the end of February 2016, Nkom was informed that the dialogue between the parties had stopped, and Nkom therefore summoned the parties to a meeting to clarify the status in the case. In the meeting between Nkom and the parties on 15 March 2016, it emerged that Broadnet had found some errors and omissions in the location data from the Grorud exchange. As a result of this, four action points were agreed at the meeting. Among other things, Telenor was to provide an account of information related to lines from end splitters to network termination points and which sources its own organisation used in the planning and determination of the roll-out of micronodes. In July 2016 Nkom concluded that the action points from the meeting had been fulfilled.

473. Broadnet did not agree that all the action points had been fulfilled and asked Nkom in a letter dated 21 September 2016 to make a final decision on Broadnet's complaint about inadequate access to location data from Telenor. In this context, Broadnet presented new information in the case that implied that Telenor had more information about lines between end splitters and network termination points and that the company has access to other sources of information that it uses in its own planning and decisions for the roll-out of micronodes. Nkom considered the new information in the case in a letter dated 6 February 2017. In this letter Nkom concluded that Broadnet had not presented any new information that indicated that the action points had not been fulfilled.

3.6.4 Notification of changes in connection with upgrade of the copper network

474. Nkom's decision of 20 January 2014 in former Market 4 contained requirements regarding the content of the reference offer, among other things. One of the requirements was an obligation to include provisions on the notification of changes to or closure of copper access lines. Telenor was also ordered to notify affected providers immediately after the changes had been decided and no later than six months before the changes were to be implemented. Furthermore, closure of copper access lines was to be notified immediately after the changes had been decided and no later than three years before the changes were to be implemented.

475. In 2015 Telenor initiated an upgrade of the copper network. The upgrade mainly consisted of laying fibre to the splitters closer to the end-user, so-called micronodes, and starting to use VDSL technology and vectoring in the micronodes. Telenor considered that it was sufficient to notify the providers with six months' notice of the changes to the copper access network as a result of the upgrade.

476. Telenor's wholesale customers did not accept this short period of notice and pointed out, among other things, that the upgrade would partially deprive the wholesale customers of

the opportunity to provide services to their own end users from the main exchange. On this basis, Nkom identified a need to clarify how the notice provisions in the Market 4 decision were to be interpreted. This was done in a letter dated 11 February 2016. Here it was stated that Telenor cannot notify all changes as a result of the upgrade with six months' notice, as in some cases regulation requires that changes are notified with three years' notice. The notice period of three years will apply in cases where the closure of connection points will lead to at least 50% of the access lines or subloop lines under the connection point being taken out of service, and these amount to 50 access lines or subloop lines or more, cf. the Market 4 decision, paragraph 348 and the operator access agreement, clause 6.2.3.

477. In its decision of 8 July 2016 Nkom ordered Telenor to change the notice period in the upgrade cases. The order to take corrective action entailed, among other things, that Telenor had to reassess the notified roll-out points and send out a new notification in those cases the company had not notified with a long enough notice period. Telenor appealed the decision, but the Ministry of Transport and Communications upheld Nkom's decision on 19 December 2017.

3.6.5 Non-disclosure and confidentiality requirements in electronic communications networks

478. In June 2015 Broadnet complained that Telenor had handled information from Broadnet in violation of the requirements defined in the Electronic Communications Act regarding non-disclosure and confidentiality, specifically Sections 2-7, 2-9 and 4-13 of the Electronic Communications Act. Broadnet commented that the information the company provides in connection with ordering wholesale products is available to Telenor's retail operations.

479. In a letter dated 21 March 2016 Nkom concluded that there were no grounds to treat Broadnet's appeal on the basis of the cited legal bases. In addition, Nkom reviewed the information submitted in the case against the obligation of non-discrimination in Markets 4 and 5. Nkom did not find it substantiated that Telenor had violated the obligation of non-discrimination.

480. Nkom later rejected a complaint by Broadnet regarding the conclusions in Nkom's letter of 21 March 2016.

481. Broadnet appealed Nkom's rejection decision. In addition, Broadnet requested that the Ministry of Transport and Communications reconsider the substantive merits of Nkom's conclusions in the letter dated 21 March 2016.

482. The Ministry of Transport and Communications decided the appeal on 23 October 2017. Broadnet's appeal regarding Nkom's rejection decision was allowed. In other words, the Ministry of Transport and Communications concluded that Nkom's decision of 21 March 2016 was an individual decision. The outcome of the substantive reconsideration of the case, however, was that the Ministry of Transport and Communications upheld Nkom's conclusions in the letter dated 21 March 2016.

3.6.6 Telenor's prices for fibre-based Broadband Access

483. Nkom conducted margin squeeze calculations on the basis of data as per the end of the first half of 2015 and in the decision dated 9 May 2016 ordered Telenor to adjust its prices for fibre-based Broadband Access such that the total wholesale costs were reduced by at least 16.9%. Telenor appealed the decision and applied to the Ministry of Transport and Communications for deferred implementation. The Ministry granted deferred implementation of Nkom's decision on the condition that Telenor set up a blocked account, held by the state, into which Telenor at each invoicing would transfer the difference between sales revenue based on the current wholesale price and the reduced wholesale price, starting from 6 June 2016 and until the Ministry made a decision in the appeal case. On 24 October 2017 the Ministry of Transport and Communications decided the appeal of Nkom's decision. The Ministry supported Nkom's assessments, but the required price adjustment was amended from 16.9% to 24.7%, as a result of the fact that Nkom had found errors in the figures used in the margin squeeze model.

484. In addition, Nkom carried out margin calculations based on data as per year-end 2015. The calculations showed that Telenor's prices for fibre-based Broadband Access were still too high. Nkom therefore issued a decision on 21 February 2017, ordering Telenor to adjust its access prices such that the total wholesale costs were reduced by 27.8%. Telenor appealed this decision too, and the appeal is currently being processed by the Ministry of Transport and Communications.

485. Nkom also conducted margin calculations on the basis of data as per the end of the first half of 2016 and in a decision dated 20 April 2018 ordered Telenor to adjust its prices for fibre-based Broadband Access such that the total wholesale costs were reduced by at least 16%. Telenor appealed this decision, and the appeal is currently being processed by the Ministry of Transport and Communications.

486. Nkom believes it was necessary to order Telenor to adjust its prices for fibre-based Broadband Access in order to meet the regulatory requirements associated with non-discrimination in terms of prices.

3.6.7 Other miscellaneous appeals

487. In May 2015, Broadnet complained that Telenor was in breach of several key obligations in Nkom's decisions in former Market 4 and Market 5. The complaint pertained to, among other things, Telenor's information and support systems, set-up fees in connection with placing an order, cancellation fees, delivery times and cancellation of orders. Broadnet asked Nkom to intervene against Telenor's behaviour pursuant to Section 11-2, first and second paragraph, (resolution of conflicts in disputes between providers) and Section 10-1 (supervision) of the Electronic Communications Act.

488. Nkom gave notice of a decision in the case on 21 March 2016. In the notification, Nkom upheld two of Broadnet's complaints by imposing on Telenor a duty to establish routines and

systems to ensure up-to-date information in information and support systems and to ensure that the wholesale customers have access to equivalent testing opportunities as Telenor's retail operations. In connection with the consideration of Broadnet's appeal, Nkom found that the published KPIs for average time for rectification of faults was in violation of the obligation imposed in the Market 4 decision, because the published results do not allow comparison between external and internal operations. In the notification Nkom therefore ordered Telenor to amend its definition of the KPIs.

489. Seven of Broadnet's points of appeal were dismissed by Nkom. In two of these, however, Nkom recognised that it might be appropriate to meet the parties for further clarification of the matter.

3.6.8 Overall assessment of the complaints and conflicts in the regulatory period – Market 3a and Market 3b

490. Nkom's experience in this regulatory period is that buyers of access are increasingly contacting Nkom in connection with conflicts and disputes with Telenor. Although some of the complaints may be an expression of strategic choices, the high level of conflict suggests that there is no effective competition in the market and that Telenor can behave independently of its competitors, customers and consumers to an appreciable extent.

491. Several of the cases pertain to central access obligations, and there seems to be a tendency for cases related to access to take a long time to resolve, for example NextGenTel's and Broadnet's requests to be able to start using SHDSL.bis. In a market characterised by competition, these kinds of cases would probably have been resolved more quickly.

492. The main case in the regulatory period was the case regarding notification of changes in connection with the upgrade of the copper network. For example, Nkom refers to the fact that this issue was discussed at length in the Broadband Forum up until Nkom made a decision in the case. Predictable access to the copper access network is essential to achieve the goal of sustainable competition in the wholesale markets for broadband. Telenor's use of the six-month notice period in the upgrade cases is an indication that Telenor has largely been able to behave independently of its competitors in respect of determining the length of the period of notice. Nkom believes that this case demonstrates that Telenor interprets the contractual terms in its favour and only to a minor degree adapts its implementation of the provisions to the access buyer's needs. This indicates that there is an imbalance of power between Telenor and buyers of access, supporting the view that Telenor has significant market power.

493. The case concerning KPIs may undermine confidence that Telenor is offering wholesale products on equal and non-discriminatory terms.

494. A recurring point that has been raised in several of the cases is that Telenor's retail operations have access to more information about the access network or better information and support systems than the buyers of access. In some of the cases, it has been proven that

this is the case. In Nkom's opinion, it is reasonable to regard Telenor's discrimination between its own internal operations and external companies as proof that the company can behave independently of its competitors and customers to an appreciable extent.

495. In summary, Nkom believes that the complaints and the relatively high level of conflict in recent years serve to strengthen the evidence that Telenor has significant market power in both Market 3a and Market 3b.

3.7 Control of infrastructure that is not easily duplicated

496. Entry barriers can generally be defined as any disadvantage that a newcomer to the market will face compared with operators that are already established. These kinds of entry barriers may have different characteristics and arise for different reasons. In the Guidelines, ESA distinguishes between structural and regulatory entry barriers.

497. In cases where an operator controls infrastructure that is not easily duplicated, and this infrastructure represents an important input factor in the relevant market, this could represent a substantial entry barrier for potential competitors.

3.7.1 Market 3a

498. To be a provider in Market 3a, operators need access to copper or fibre-based infrastructure in the access network. Providers that do not have this kind of infrastructure must establish it.

499. In order to establish infrastructure in the access network, the operator must have access to or establish new cabling routes. The establishment of new cabling routes is expensive and represents about two-thirds of the total investment in connection with building new fibre-based access networks. If an operator has access to existing cabling routes, the overall construction costs of rolling out a network will be significantly reduced.

500. In addition to being costly, the establishment of new cabling routes requires permission from the landowner. Establishing cabling routes also requires permission from the local municipal authorities, which can be challenging, as to date different municipalities have had different excavation rules. However, it is expected that practice will be more uniform in the future as a result of the Ministry of Transport and Communications' amendments to the so-called cable regulations, see Section 3.14.2. The changes include more harmonised rules for excavation work and better coordination in connection with the planning and execution of cable laying under roads. But even with more harmonised excavation rules, the cost of establishing fibre-based access networks will be considerably lower for an established provider that can exploit existing cabling routes than for a new provider that needs to establish new cabling routes.

501. The Ministry of Transport and Communications has also proposed new legislation to facilitate the roll-out of high-speed electronic communications (the Broadband Development

Act). Measures are proposed in the Broadband Development Act to facilitate shared use of physical infrastructure suitable for the provision of high-speed networks⁴³. This Act is expected to make it less costly to establish new broadband networks.

502. Telenor owns and controls access infrastructure throughout the whole of Norway. Technically, it is possible to establish a physical access network parallel to Telenor's nationwide access network. In practice, however, establishment of an adequate alternative to Telenor's access network would be so resource-intensive and expensive that it is considered completely improbable that this network will be duplicated in the same scale as Telenor's network.

503. At the same time, there has been relatively extensive roll-out of fibre access networks in recent years. This has largely been done by energy companies that have infrastructure in a limited geographical area. The situation with respect to control over infrastructure that is not easily duplicated has therefore become more nuanced in parts of Norway.

504. On the other hand, Telenor has increased its investments in fibre⁴⁴. Combined with the possibility of obtaining speeds that can compete with fibre and HFC networks through the upgrading of the copper network in some areas, this could contribute to maintaining Telenor's control over infrastructure that is not easily duplicated.

505. Since it will require considerable investments for other access network owners to establish a wholesale provision with local access that covers as much of the country as Telenor's existing services, Telenor's nationwide control of the infrastructure in Market 3a is still considered to give the company a significant competitive advantage and constitute a substantial entry barrier. Nkom believes that access to infrastructure that is not easily duplicated supports the presumption that Telenor has significant market power.

3.7.2 Market 3b

506. Operators wishing to enter Market 3b can base their provision of services on copper or fibre-based LLU from Telenor or on their own access network. Potential providers in this market therefore do not necessarily have to establish their own physical access lines to be able to compete with Telenor. Since Telenor basically sets the terms for competitors that base their provision on LLU, the competition from these providers could potentially be weakened if Telenor sets unfavourable access terms. So far, however, copper-based LLU has been subject to price controls, and this has limited Telenor's capability to weaken the competition of providers that purchase LLU. In the case of fibre-based LLU, Telenor has to date been subject to an obligation of non-discrimination. However, there are a very limited number of available accesses, and so far no access buyers have taken advantage of Telenor's offering, as far as Nkom knows.

⁴³ See the description of the Broadband Development Act in Section 3.14.

⁴⁴ <https://www.insidetelecom.no/artikler/fiberkamp-de-neste-tre-fire-arene/376024>

507. Operators that choose to base their wholesale offering in Market 3b on LLU must, in the same way as Telenor, invest in equipment in the subscriber exchanges. This is largely standard 'off the shelf' equipment and so cannot be regarded as not easily duplicated.

508. Furthermore, it is possible technically to establish physical infrastructure in parallel with Telenor's copper, HFC and fibre access networks in order to be a provider in Market 3b. In other words, Telenor does not have control over infrastructure that it is impossible to duplicate in technical terms. The developments in recent years show that it is possible to build fibre access networks and other alternative access networks instead of copper-based broadband services. The biggest difference between Telenor's access network and the emerging networks is that the regional operators generally build their networks in their regions where they have access to masts, buildings and cabling routes, and thus there is no immediate nationwide coverage.

509. Since it will require considerable investments for other access network owners to establish a wholesale provision with central access that covers as much of the country as Telenor's existing services, Telenor's nationwide control of the infrastructure in Market 3b is still considered to constitute a substantial entry barrier that provides a substantial competitive advantage. This kind of competitive advantage enables Telenor to exert considerable influence in the relevant market and strengthens the evidence that Telenor has significant market power.

3.8 Sunk costs

510. Sunk costs are unrecoverable costs due to an irreversible investment. This means that a provider cannot expect to recover the investment once it has been made, for example through the sale of an investment item, if the provider wishes to exit the market. Unrecoverable fixed costs mean that a potential newcomer faces higher decision-relevant costs than the operator(s) already established. This cost difference can constitute an entry barrier to a potential entrant.

511. If entry into a market requires high sunk costs, the established operator may have an incentive to make a more extensive investment than it otherwise would have done. This can send a signal to potential newcomers that it would not be profitable to attempt to enter the market. Sunk costs can therefore give rise to strategic behaviour among the established operators, further raising the entry barrier.

512. Intangible investments can also be unrecoverable and represent an entry barrier. Investment in brand building (for example through advertising and other marketing) is an example of such investments.

3.8.1 Market 3a

513. Telenor owns a nationwide access network, which has been built up over many years. There is little doubt that it would be extremely resource and cost-intensive for a potential

competitor to establish a rival access network on an equally large scale. There is furthermore little doubt that such an investment would largely have to be viewed as irreversible and thereby represents a form of entry barrier.

514. For potential providers that have the use of infrastructure in a limited geographical area, sunk costs associated with roll-out in the relevant area will constitute a minor entry barrier. As a result of the fact that these kinds of roll-outs are often initiated after a certain number of end-user agreements have been entered into in the relevant area, potential providers will nevertheless have to expect to spend money on advertising and marketing in the retail market. These sunk costs will constitute a form of entry barrier.

515. Since it will require considerable investments for potential providers to establish a wholesale provision in Market 3a that covers as much of the country as Telenor's existing services, Nkom finds that sunk costs constitute a significant entry barrier that provides Telenor with a substantial competitive advantage in Market 3a. This reinforces the presumption that Telenor has significant market power.

3.8.2 Market 3b

516. Operators wishing to enter Market 3b can base their provision of services on copper or fibre-based LLU from Telenor or on their own access network. Potential providers in this market therefore do not necessarily have to establish their own physical access lines to be able to compete with Telenor.

517. Telenor owns a nationwide access network, which has been built up over many years. There is little doubt that it would be extremely resource and cost-intensive for a potential competitor to establish a rival access network on an equally large scale. There is furthermore little doubt that such an investment would largely have to be viewed as irreversible and thereby represents a form of entry barrier.

518. For potential providers that have the use of infrastructure in a limited geographical area, sunk costs associated with roll-out in the relevant area will constitute a minor entry barrier. As a result of the fact that these kinds of roll-outs are often initiated after a certain number of end-user agreements have been entered into in the relevant area, potential providers will nevertheless have to expect to spend money on advertising and marketing in the retail market. These sunk costs will constitute a form of entry barrier.

519. Operators that choose to base their wholesale offering in Market 3b on LLU from Telenor must invest in equipment in the subscriber exchanges. This kind of equipment represents a sunk cost, but only to a limited degree represents an entry barrier, as a result of the fact that these costs are largely standard "off the shelf" items.

520. As a result of the fact that potential providers that want to establish a wholesale offering in Market 3b do not necessarily have to establish their own physical access lines to compete with Telenor, these sunk costs represent a much smaller entry barrier in this market than in

Market 3a. Nkom nevertheless finds that the sunk costs required to be able to be a provider in Market 3b give Telenor a certain competitive advantage. This supports to a certain degree the arguments that Telenor has significant market power.

3.9 Vertical and horizontal integration

521. A vertically integrated provider is a provider that has control over several links in the relevant value chain and will often be present in both infrastructure markets (“upstream markets”) and retail markets (“downstream markets”). Vertical integration yields efficiency gains through better utilisation of capacity and resources, paving the way for economies of scale. These kinds of gains can also be passed on to the retail market in the form of lower prices, reduced transaction costs and increased quality.

522. Vertical integration may also serve to raise the cost of entering a market, as the newcomer would have to enter several markets in order to be able to compete effectively with the vertically integrated provider. Vertical integration can also provide the ability to counteract or eliminate competitors by limiting the competitor’s access to necessary input factors or by setting a higher price for such access than is offered to the provider’s own retail operations. A vertically integrated provider with a strong position in the upstream market can thus use this position to strengthen its position in the downstream market.

523. Horizontally integrated providers have operations in two or more markets that are not vertically related to each other. As a consequence of their broad product portfolio and large customer base within several markets for electronic communications, these kinds of providers will have increased economies of scope in the relevant market⁴⁵. If a horizontally integrated provider has market power in a related market, the provider will be able to influence the competition in the relevant market.

3.9.1 Market 3a and Market 3b

524. Telenor is vertically integrated and offers broadband products in both the retail and the wholesale markets. Its position as the largest provider in both the wholesale and the retail market means Telenor has the possibility to achieve advantages from being vertically integrated. Telenor’s large customer base in the retail market also provides opportunities to strengthen the company’s strong position in the wholesale markets.

525. The fact that Telenor offers services in both the retail market and the wholesale markets also means that Telenor is competing with its wholesale customers in the retail market. One consequence of this is that Telenor is less dependent on its external wholesale sales. In fact, it may be profitable for Telenor to try to maximise its overall profits by limiting access to its wholesale services and thereby limiting the competition in the retail market.

⁴⁵ See Section 3.10 on economies of scope.

526. Telenor is also a horizontally integrated company and has a strong position in a number of adjacent markets within electronic communications. At the retail level, Telenor has the opportunity to provide services in a variety of areas beyond fixed broadband, including fixed telephony, mobile telephony and TV services. Similarly, Telenor also has a strong position in a number of adjacent wholesale markets. Telenor's large geographical coverage and broad product range at both the retail and the wholesale level enables the company to reap the benefits of horizontal integration.

527. Against this backdrop, Nkom holds that vertical and horizontal integration gives Telenor a competitive advantage that strengthens the view that Telenor has significant market power in the relevant wholesale markets.

3.10 Economies of scale and scope

528. Economies of scale and scope are potential advantages that a larger provider has compared with smaller providers. These kinds of advantages can work both as entry barriers for new potential operators and as a competitive advantage for established operators in the market.

529. Economies of scale exist when an increase in production brings a fall in average unit cost. This is characteristic of production based on technology with relatively high fixed costs and low variable costs. Economies of scope exist when the average unit cost is reduced because more than one service is produced using shared means of production, for example a shared infrastructure or administrative systems.

3.10.1 Market 3a

530. Nkom finds that Market 3a is characterised by economies of scale. This is because a large proportion of the costs of building and maintaining an electronic communications network are fixed, entailing falling average costs as the number of customers in the network increases. Since the wholesale products in Market 3a will be able to serve as an input factor in the production of multiple services in the retail market, Nkom believes the market is also characterised by economies of scope.

531. Telenor has significantly greater economies of scale than its competitors as a result of its nationwide infrastructure and large customer base. Telenor also has significantly greater economies of scope than its competitors, as a result of its broad portfolio of products. Telenor will also have other economies of scope linked to sales, invoicing and customer service, for example. Several of Telenor's products use the same underlying infrastructure in varying degrees, and in Nkom's opinion, it is not likely that other providers will be able to build up similar economies of scale and scope in the short or medium term.

532. On the other hand, it is not a given that these economies of scale and scope represent an equally significant entry barrier for potential providers within a geographical area. Several of

Telenor's competitors in the broadband market may also have not-insignificant economies of scale and scope. This is particularly the case for the energy companies that have established wholly or partly owned broadband companies. For example, it will make sense for these broadband companies to use existing masts, buildings and cabling routes, in addition to invoicing and customer service systems already used in connection with the energy companies' core operations.

533. Entering Market 3a requires a large initial investment in infrastructure in the access network. For this to be profitable, the prospective provider must have a certain number of customers in the retail and/or the wholesale market within a certain geographical area. If the prospective provider enters the market, the cost of producing an additional unit will decline as the number of customers increases.

534. Local access will necessarily have a smaller customer base than access at a more central point. There are thus fewer prospective customers to share the fixed costs among, and it is considered harder to achieve economies of scale and/or scope.

535. Telenor's nationwide infrastructure and large customer base, in both the retail and the wholesale market, mean the company has considerable economies of scale and scope compared with competitors that wish to offer local access to an equally large part of the country as Telenor's existing provision. This reinforces the presumption that Telenor has significant market power.

3.10.2 Market 3b

536. Nkom finds that Market 3b is characterised by economies of scale. This is because a large proportion of the costs of building and maintaining an electronic communications network are fixed, entailing falling average costs as the number of customers in the network increases. Since the wholesale products in Market 3b will be able to be an input factor in the production of multiple services in the retail market, Nkom believes the market is also characterised by economies of scope.

537. However, providers in Market 3b do not need to establish their own physical access lines to their customers. They can also base their provision on Telenor's infrastructure by purchasing copper or fibre-based LLU. This means that initial investments in Market 3b will be lower than in Market 3a. Since the connection point for Market 3b is further upstream than for Market 3a, there will also be a larger customer base, meaning more potential customers to distribute fixed costs among.

538. Telenor nevertheless has significantly greater economies of scale than its competitors as a result of its nationwide infrastructure and large customer base. Telenor also has significantly greater economies of scope than its competitors, as a result of its broad portfolio of products. Telenor will also have other economies of scope linked to sales, invoicing and customer service, for example. Several of Telenor's products use the same underlying

infrastructure in varying degrees, and in Nkom's opinion, it is not likely that other providers will be able to build up similar economies of scale and scope in the short or medium term.

539. On the other hand, it is not a given that these economies of scale and scope represent an equally significant entry barrier for potential providers within a geographical area. Several of Telenor's competitors in the broadband market may also have not-insignificant economies of scale and scope. This is particularly the case for the energy companies that have established wholly or partly owned broadband companies. For example, it will make sense for these broadband companies to use existing masts, buildings and cabling routes, in addition to invoicing and customer service systems already used in connection with the energy companies' core operations.

540. Telenor's nationwide infrastructure and large customer base, in both the retail and the wholesale market, nevertheless mean the company has considerable economies of scale and scope compared with competitors that wish to offer central access to an equally large part of the country corresponding to Telenor's existing provision. As a result of the fact that significantly lower investments are required to become a provider in Market 3b than in Market 3a, and the fact that the customer base in Market 3b is significantly larger, since the connection point is further upstream, Telenor's economies of scale and scope compared with the other competitors are considerably smaller in the market than in Market 3a. Nkom nevertheless believes that Telenor has economies of scale and scope in Market 3b that yield a competitive advantage, strengthening the evidence that Telenor has significant market power.

3.11 Product differentiation

541. "Product differentiation" means a strategy that aims to give a provider's own products characteristics that distinguish it from the products of rival providers. Product differentiation can take place in both the retail and the wholesale market. A high degree of product differentiation by a provider may provide a basis for strong customer loyalty and thus reduce the competition in the market.

542. Bundling of products is one form of product differentiation. An operator with market power in a relevant market can link services or products in this market to services or products in another market, so that the operator can provide a bundle of services and/or products that are differentiated from the competitors' offerings and that the competitors have a limited opportunity to copy. In this way, the bundling of services and/or products can contribute to market power in one market creating competitive advantage in another market. These types of competitive advantages may be relevant to the assessment of significant market power.

3.11.1 Market 3a and Market 3b

543. Telenor has a nationwide copper network, as well as being a major player in several alternative electronic communications networks, including fibre networks, HFC networks,

satellite networks and wireless access networks. Moreover, Telenor has a broad range of products and greater geographical coverage than its competitors and potential competitors in both the retail and the wholesale markets.

544. At the wholesale level, Telenor therefore has greater opportunity to act as a total supplier than other providers in these markets, for instance by bundling access and trunk products in the same delivery and by having offerings throughout the whole country. Telenor's bundling of access and trunk products, through products such as E-line, can therefore be regarded as constituting a competitive advantage for Telenor in the relevant wholesale markets. As far as Nkom knows, there is only one case of bundling in Market 3b, but Telenor has the opportunity to undertake similar bundling of its products in Market 3a.

545. At the retail level too, Telenor has the opportunity to differentiate its products to a greater extent than its competitors by bundling retail products and services from multiple markets. This kind of product differentiation helps strengthen Telenor in the competition with its own wholesale customers and alternative providers with their own networks in the retail market. By exploiting its competitive advantages in the retail market, Telenor is less disciplined by the competition from alternative providers with their own network, entailing that Telenor can behave more independently in the wholesale market.

546. On this basis, Nkom has concluded that product differentiation in the form of bundling in the retail and wholesale markets and a nationwide offering serve to strengthen the view that Telenor has significant market power in Market 3a and Market 3b.

3.12 Access to financial resources

547. Access to financial resources will be central to an operator's opportunity to enter and expand in markets requiring large initial investments. Access to financial resources will thus be an obstacle to both entry and growth. For a provider with a strong position in the relevant market, good access to financial resources will also strengthen the provider's ability to defend its market shares and thus serve to increase entry barriers.

548. Under the criterion "control over infrastructure not easily duplicated", Nkom has found that market entry as a provider of access in Market 3a would require large initial investments. The same is true for expansion entailing the roll-out of broadband networks in new areas. Good access to financial resources will therefore be necessary for entry and expansion in this market. As stated above in connection with the assessment of the same criterion in Market 3b, market entry as a provider of access there could be done with similar investments as in Market 3a, but could also be achieved with a significantly smaller need for investment. Since there has only been very limited such entry in practice and there is no evidence to suggest that this will change in the time horizon of the analysis, Nkom finds that there are grounds to assess the criterion of financial strength for Market 3a and Market 3b together.

3.12.1 Market 3a and Market 3b

549. It will be very capital intensive to establish an adequate alternative to Telenor's nationwide infrastructure. Nkom does not consider this kind of entry to be a realistic scenario during the period covered by the analysis. By contrast, the roll-out of fibre by alternative providers shows that Telenor's competitors have established competing infrastructure in certain parts of the country. Operators that entered the broadband market with their own infrastructure have generally been locally or regionally based operators wholly or partly owned by large energy companies. Nkom sees the establishment of competing infrastructure as an indication that access to financial resources does not to any appreciable degree constitute an entry barrier for geographically delimited establishment in the relevant market. Many of these operators also have a clear strategy to actively expand into new areas.

550. In Section 3.4, in connection with the discussion of the criterion "size of the companies", Nkom has shown that Telenor has by far the largest sales revenue in the Norwegian electronic communications markets. In addition, Telenor has achieved a strong financial position in 2017⁴⁶. In Nkom's opinion, the combination of a strong position in a number of Norwegian electronic communications markets, high sales revenues and very good profitability supports the view that Telenor has a stronger financial position than its competitors, and especially relative to the smaller broadband operators. At the same time, several of Telenor's competitors, particularly local and regional fibre companies owned by large energy companies, have a financial strength not dissimilar to Telenor's. Nor can it be ruled out that operators that are not currently in the relevant market, or that only have very minor operations in the relevant market, will enter this market within a relevant time frame and that these operators might have financial strength similar to Telenor's.

551. In view of ability to defend market shares and ability to endure a price war or dumping (so-called "long purse"), Nkom believes that Telenor's strong financial position will deter the establishment of alternative infrastructure to a certain extent. This kind of effect would be particularly noticeable in areas where Telenor already has infrastructure that enables high-capacity broadband.

552. On this basis, Nkom believes that financial strength constitutes a slight advantage for Telenor, compared with the company's competitors. By contrast, Nkom cannot see that financial strength is an indicator that unambiguously supports the view that Telenor has significant market power.

3.13 Access to distribution and sales channels

553. A mature distribution and sales network may act as a barrier to new entrants to the market and as a competitive advantage for established operators. This applies in particular in

⁴⁶ Telenor's annual report for 2017 p. 6: <https://www.telenor.com/wp-content/uploads/2018/04/iPDF-%C3%85rsrapport-2017-Q-06d5e4971377d33c346a09d54124397e.pdf%C2%A0>

markets in which there are major costs associated with the building up of distribution networks, or where the established operators have concluded exclusive agreements with the largest or most important distribution channels in the market.

3.13.1 Market 3a and Market 3b

554. The wholesale customers in Markets 3a and 3b consist of providers of electronic communications networks and/or services. The wholesale customers thus mainly comprise professional operators with a good overview of the market. In Nkom's opinion, there will be a relatively limited number of wholesale customers, and Nkom finds that the relevant markets are relatively clear. Nkom therefore believes that access to distribution and sales networks do not really constitute a supply-side entry barrier in the relevant markets.

555. Access to distribution and sales channels will constitute an entry barrier and competitive advantage in the corresponding retail market and thereby may serve to ensure that vertically integrated providers can maintain or strengthen their position in the relevant markets. However, purchases of broadband services largely happen online or by direct sales (by telephone or door-to-door sales) and are less linked to physical outlets. In Nkom's opinion, this reduces the significance of access to distribution and sales channels as an entry barrier and competitive advantage in the relevant retail market.

556. Nkom concludes that Telenor does not have a significant special advantage through its access to distribution and sales channels that provides a competitive advantage in relevant markets. This criterion does not strengthen the view that Telenor has significant market power in the relevant markets.

3.14 Regulatory measures that may facilitate market entry

557. In this section, Nkom will review various regulatory measures that might help reduce entry barriers in connection with the roll-out of broadband.

3.14.1 The Broadband Development Act

558. On 15 May 2014 the European Parliament and Council adopted a directive with measures to reduce the cost of deploying high-speed electronic communications networks, cf. Directive 2014/61/EU. The Directive defines "high-speed electronic communications network" as an electronic communication network which is capable of delivering broadband access services at speeds of at least 30 Mbps, cf. Article 2 no. 3).

559. The main aim of the Directive is to facilitate and incentivise the roll-out of high-speed electronic communications networks by promoting the joint use of existing physical infrastructure and by enabling a more efficient deployment of new physical infrastructure through better coordination of construction, excavation and civil engineering projects. In

addition, it also requires that all newly constructed buildings and major renovation of buildings must be equipped with a high-speed-ready in-building physical infrastructure.

560. In summer 2016 the Ministry of Transport and Communications conducted a consultative hearing with proposals that the Directive be implemented in a new law to facilitate the roll-out of high-speed electronic communications (the Broadband Development Act).

561. In the draft bill, it is proposed to introduce an obligation for network providers that have the right of use of infrastructure suitable for the provision of high-speed networks to grant providers of public electronic communications networks that want to roll out high-speed networks access to this infrastructure. Network providers will, in addition to providers of electronic communications networks, include businesses that provide physical infrastructure that is made available for the provision of services in connection with production, transport, including railways, roads, ports and airports or distribution of gas, electricity and public lighting, heating, and water and drainage systems. Access must be granted on fair and reasonable terms.

562. In addition, the Ministry of Transport and Communications has proposed the establishment of a central information service to disclose information about existing physical infrastructure, planned and ongoing building and construction works, and application and licensing procedures relating to these kinds of projects.

563. It is assumed that the proposed regulation will reduce the costs for developers of high-speed broadband through the use of other companies' infrastructure. Furthermore, costs will be reduced due to better coordination of construction projects and better information on planning and engineering.

564. The cost savings will make it more profitable to roll out high-speed networks and thereby contribute to increased infrastructure-based competition. The Broadband Development Act may thus make it easier to roll out broadband.

3.14.2 Regulations on cable above, below and alongside public roads

565. The Ministry of Local Government and Modernisation, the Ministry of Petroleum and Energy and the Ministry of Transport and Communications issued a joint consultation letter on measures to improve coordination etc. in connection with the planning and execution of cable laying under roads on 6 June 2017, including suggestions for proposed amendments to the cable regulations.⁴⁷ The measures will entail, among other things, amendments to the cable regulations intended to ensure better balance between the road interests and the cable interests in respect of access to the limited amount of space under roads. Another objective of the measures is to ensure identical rules across the whole country and uniform practice, as far as is possible, in terms of the setting of terms and conditions etc. for cable work.

⁴⁷ Regulation no. 1212 of 8 October 2013 on the processing and responsibilities in connection with the laying and moving of cables above, below and alongside public roads.

566. The amendments to the cable regulations were approved by the Ministry of Transport and Communications on 24 November 2017 and entered into force on 1 January 2018.

3.14.3 The state aid scheme to roll out broadband infrastructure

567. The state aid scheme to roll out broadband infrastructure is a state subsidy financed over the national budget. The scheme has existed in its current form since 2014. The scheme provides state aid for roll-out of broadband infrastructure in areas where roll-out is not commercially profitable. The objective of the scheme is to contribute to all households receiving an offer of broadband that is of fundamentally good quality. Subsidies may also be granted to increase broadband capacity in areas where new commercial offerings cannot be expected in the next few years. Municipalities and county municipalities can apply for subsidies through the scheme.

568. The scheme has been approved by the EFTA Surveillance Authority based on the EU guidelines for broadband support⁴⁸. The Guidelines include a number of requirements regarding state aid that may have particular relevance to competition in the broadband market. The Guidelines require, among other things, that the allocating authorities must ensure that commercial development of broadband in the relevant area within the next three years has not been initiated or had plans approved. In Norway this is ensured by the fact that the municipalities and county municipalities chart this in connection with their applications for state aid. To ensure that the public support does not lead to the creation of local monopolies, the Guidelines also specify that infrastructure that is granted support must be open for third-party access. In Norway, a project owner must therefore set requirements regarding third party access in the call for tenders.

569. The Norwegian state aid scheme to roll out broadband infrastructure will make it easier for developers to roll out broadband in parts of Norway on the basis of government subsidies, but the impact will be limited as the scheme only applies in areas where roll-out is considered to be not commercially profitable.

3.14.4 Overall assessment of the suitability of the regulatory measures to facilitate market entry

570. The various regulations mentioned above may potentially result in significant cost savings for broadband developers. However, this will depend on many factors. For example, Nkom will assume that the number of requests for access to alternative infrastructure pursuant to the Broadband Development Act will depend on whether electronic communications providers find it easy to obtain this kind of access. If many requests end up in a dispute on whether access is to be granted and/or the conditions for this kind of access, this would make

⁴⁸ EU Guidelines for the application of State aid rules in relation to the rapid deployment of broadband networks (2013/C25/01)

access very inefficient and lead to electronic communications providers refraining from making such requests.

571. The proposed cable regulations were well received by the broadband developers in the consultation hearing in summer 2017. For example, this was reflected in the consultation statement from the fibre players in the Broadband Forum⁴⁹. The Broadband Forum points out that the changes will resolve certain elements of dispute that have slowed down the development of infrastructure. The Broadband Forum mentions relaxation of the requirements concerning cable coverings and clarification of which costs a developer can apply to have covered by the road authorities as examples. Nkom believes that the new rules will have a major practical and financial impact on the broadband operators' ability to roll out broadband in the future.

572. With regard to the state aid scheme to roll out broadband infrastructure, the amount that the Storting allocates to the scheme will, as known, vary from year to year. In addition, the scheme will only lead to roll out in limited geographical areas. The scheme will thus not facilitate the roll out of broadband in general to an appreciable degree.

573. Nkom's overall assessment of the various regulatory measures is that they will have a positive effect on the roll-out of broadband in the coming regulatory period for all operators and may thus to some extent serve to reduce Telenor's market power in the broadband markets.

3.15 Potential competition

574. In this context, potential competition relates to whether operators that are not in the relevant market will be able to enter the market and thus contribute to creating market dynamics within the period covered by the analysis. The threat of increased competition from these kinds of operators will be able to exert a disciplining effect on the ability of established operators to exercise market power.

3.15.1 Market 3a and 3b

575. Potential competition in Markets 3a and 3b may come from either operators that establish new access networks, in practice fibre networks, or from vertically integrated providers with their own access networks that currently do not offer access to external buyers of access.

576. In the above, Nkom has provided an account of the high structural entry barriers for operators that want to establish themselves as suppliers of access in Markets 3a and 3b. Nkom has also provided an account of the measures implemented by the government that in a forward-looking perspective may help reduce the barriers to establishment of new infrastructure, but has concluded that the structural entry barriers will still be high within the

⁴⁹ <https://www.nkom.no/aktuelt/nyheter/attachment/30716?ts=15f58242d4d>

time horizon of this analysis. On this basis, Nkom cannot see that potential competition from operators that have not already established the necessary infrastructure will be able to have any major disciplining effect during the period covered by the analysis.

577. Alternative providers have established a large number of fibre accesses in recent years. As was shown in Section 3.3 on market shares, these are used almost exclusively to provide services to their own vertically integrated service provider operations. These kinds of providers, such as Viken and Lyse, have already made high, irreversible investments in broadband infrastructure and will, with relatively modest investments in the short-to-medium-term, thus be able to also offer wholesale access to external buyers of access. Although these providers' broadband networks are concentrated in clearly delimited geographical areas and are not as omnipresent as Telenor's access network, such a provision might have a disciplining effect on Telenor's ability to exercise market power in the relevant markets. Until now, fibre operators such as Lyse and Viken have not signalled any interest in offering wholesale access in their networks. However, Nkom does not have any evidence to rule out that this type of operator might be able to offer such access during the period covered by the analysis. Potential wholesale access in other fibre networks will thereby, to a certain extent, be able to exert a disciplining effect on Telenor in Markets 3a and 3b.

578. In Section 2.4.4.1 Nkom has concluded that HFC networks are included in Market 3b. Get is a major provider of broadband access in the end-user market and offers broadband services based on the docsis 3.0 standard⁵⁰. It is possible for Get to use its HFC network to offer wholesale services in Market 3b without undertaking major investments. The threat that any such offer might constitute direct competition pressure in Market 3b and more indirect competition pressure in Market 3a, and thereby have a disciplining effect on Telenor's opportunity to exercise market power in the respective markets. Until now, Get has not signalled any interest in offering wholesale access in its network. However, Nkom has no evidence to rule out that Get will be able to offer such access during the period covered by the analysis, and we refer, among other things, to how Telia's acquisition of Get might result in strategy changes. On this basis, Nkom upholds that potential wholesale access to Get's HFC network might, to some extent, have a disciplining effect on Telenor in Market 3b.

579. In Section 2.3.3, Nkom has concluded that mobile network based broadband access is not sufficiently substitutable with fixed broadband access for mobile-based broadband access to be included in the relevant markets. However, the trend towards increasingly large capacities in mobile broadband networks is a factor that in the long run may affect this assessment and which may give grounds to assess whether broadband access in mobile networks can have a disciplining effect in the form of potential competition or indirect competition pressure. However, Nkom cannot see that access in mobile networks will be able to have this kind of effect in the relevant market to an appreciable degree. First Nkom refers to

⁵⁰ Get has announced that they will update with docsis 3.1 during the autumn of 2018: <https://itavisen.no/2018/06/29/her-laster-get-ned-med-spinnville-hastigheter-og-det-kan-du-snar-ogsa/>

the fact that there is no evidence that sufficiently many end users will regard mobile broadband as a substitute for fixed broadband access in the period covered by the analysis. Nkom also refers to the fact that the demand side in the relevant markets is only represented in the mobile markets to a modest degree. These providers will face not-insignificant entry barriers in the event of a partial transition to offering mobile-based broadband access, reducing the potential disciplining effect of this kind of market entry. In addition, Telenor has a strong position as a provider of broadband access based on its mobile-network. This also supports the view that this kind of development is less likely to weaken Telenor's market power in the relevant markets.

580. Nkom cannot see that there are grounds to assume that broadband services based on fixed radio access will be able to have a disciplining effect on Telenor in the relevant markets in the period covered by the analysis and does not find reason to pursue this in more detail.

581. Pursuant to the rules for state support, providers are obliged to provide access to networks for which they have received public funding for broadband roll-out. Through the work of the Broadband Forum, in 2016 the providers have established a framework for access to fibre networks that have received public funding. The framework, in terms of factors other than price, is intended to help streamline this access obligation. Support has been granted for approximately 10,000 accesses per year in the past four years. The number of accesses with an access obligation is thus relatively small. In addition, funding has largely been given to relatively small projects with a limited number of accesses. The providers that have participated in the Broadband Forum have expressed that it is necessary to be able to reach a certain minimum number of end users in order for it to be profitable to buy access and that therefore only a small share of the networks that have received funding will be based on purchase of access.

582. On this basis, Nkom concludes that potential competition will only to a certain degree have a disciplining effect on Telenor's ability to behave independently of competitors, customers and consumers, cf. Section 3-1 of the Electronic Communications Act.

3.16 Countervailing buying power

583. Countervailing buying power is a factor that can discipline a provider's market behaviour. Buying power may be said to exist when a defined buyer or group of buyers of a product or service is so important to the seller as to be able to influence the seller's price and other conditions for the product or service. Buying power is related to factors such as the size of the customer, purchase volumes or the fact that the customer has something to offer in return, such as access to other markets.

584. A threat not to buy can be a strong bargaining tool on the part of the buyer. The effectiveness of this bargaining tool will depend on how attractive the buyer is to the seller, and whether there are alternative providers with which to enter into agreements, and how attractive

they are. In order for buying power to be regarded as sufficiently effective, it is necessary that the disciplining effect of the buying power benefits larger portions of the market and not only affects the conditions for a limited portion of the market.

585. Buying power is not an absolute concept; rather it refers to the relative power of a buyer in negotiations with a seller for specific goods or services. The degree of buying power will thus vary according to the particular constellation of buyers and sellers. The question here is whether, in the short or medium term, one or several existing buyers will be able to exert influence on prices and other terms to such an extent that Telenor cannot be considered to have significant market power in the relevant markets.

586. In Nkom's view, the extent to which there is sufficient buying power will essentially depend on whether any access buyer's purchasing volume represents a large portion of Telenor's total volume of broadband and whether the access buyers have real alternatives to purchasing access from Telenor.

3.16.1 Market 3a and Market 3b

587. The demand side in Market 3a and Market 3b are relatively concentrated. NextGenTel and Broadnet are the largest buyers of access in both markets and together account for 73 % of the external purchases in Market 3a and 89 % of the external purchases in Market 3b, measured by number of accesses. Nkom bases the rest of the assessment on the degree of buying power these two might be able to exercise.

588. The fact that NextGenTel and Broadnet represent such a high proportion of Telenor's external wholesale sales might in theory suggest that these two providers have a certain degree of buying power. However, the question is not whether there is a certain degree of buying power, but whether the buying power is sufficient to have a disciplining effect to such an extent that Telenor cannot behave independently of its competitors, customers and consumers to an appreciable extent, cf. Section 3-1 of the Electronic Communications Act.

589. Telenor is vertically integrated and the company's wholesale operations are therefore not dependent on the players on the demand side in the relevant markets in order to be able to provide services in the retail market. However, Telenor's retail operations are in direct competition with operators on the demand side in Market 3a and Market 3b. When assessing buying power, it is also necessary to take Telenor's sales of access to its own retail operations into account.

590. NextGenTel is by far the largest buyer of access, with a share of external wholesale purchases from Telenor of 42 % in Market 3a and 59 % in Market 3b at the end of 2017. At the same time, NextGenTel had a market share of the retail market of 5.4 %, measured by number of subscriptions. The corresponding market share in the retail market for Telenor was 40 %. The largest external buyer of access thus has a considerably lower market share than Telenor in the retail market. The fact that Telenor is competing in the retail market with its wholesale customers and that Telenor's own retail operations are considerably larger than the largest

external access buyer, suggests that there is no buying power that is sufficient to discipline Telenor.

591. It follows from Section 3.3 above that Telenor has an almost 100 % market share, measured by external sales in Markets 3a and 3b. This high market share is linked to the fact that other providers only offer access to a very modest degree. This means that buyers of access from Telenor have very few real alternatives to buying access and therefore very limited opportunity to threaten to change supplier. As stated above, Nkom cannot see that there is any evidence that this will change significantly within the time frame of this analysis. It also follows from the analysis above that the markets are characterised by high entry barriers, meaning a threat of producing oneself only to a limited degree can be assumed to constitute buying power. In Nkom's opinion, the absence of real alternatives is a factor that supports the view that no adequate level of buying power exists.

592. In Section 3.6, Nkom has provided an account of the complaints and supervisory matters pursuant to Nkom's decision in the former Markets 4 and 5 of 20 January 2014. Here it is shown that both NextGenTel and Broadnet have lodged complaints with Nkom. A main feature in the complaints is that the access buyers believe they are discriminated against in various ways compared with Telenor's own retail operations and that their ability to compete in the retail market is therefore being restricted. The fact that the access buyers lodge complaints with the supervisory authority is not in itself decisive for the assessment of buying power. Nkom nevertheless believes that the complaints may to a certain extent be regarded as indicating that the two main access buyers do not have buying power that has a sufficient disciplining effect on Telenor as an external service provider. In addition, several of the complaints have been allowed.

593. Nkom concludes that it is unlikely that countervailing buying power is sufficiently able to discipline Telenor in Market 3a and Market 3b. In Nkom's opinion, countervailing buying power is therefore not a factor that supports the view that Telenor does not have significant market power in the relevant markets.

3.17 Competition pressure from the retail market

594. Competition pressure from the retail market associated with the relevant wholesale markets may limit the possibility for a provider to behave independently of its competitors, customers and consumers in the relevant markets to an appreciable extent. This kind of competition pressure is referred to as indirect competition and is relevant both in connection with the delimitation of the relevant markets and in assessing significant market power. Indirect competitive pressure from the retail market can arise if operators in the retail market offer substitutes to the retail products offered using Telenor's wholesale products as an input factor. The question is how much of a disciplining effect this kind of competition has on Telenor's ability to exercise market power in the relevant wholesale markets.

3.17.1 Market 3a and 3b

595. In the above, Nkom has referred to the fact that Telenor's competitors have increased their market shares in recent years and that this is partly linked to the share of broadband subscriptions in the retail market that are based on HFC networks and fibre-based access networks. Nkom's electronic communications statistics for 2017 show that the share of broadband services in fixed networks offered via HFC networks and fibre access were 29% and 43% respectively, based on number of subscriptions. Together with copper-based broadband access, these access forms constitute 98% of the combined broadband offerings in fixed access networks. Nkom will therefore base its assessment on whether broadband offerings in the retail market based on HFC and fibre networks constitute a sufficiently disciplining force on Telenor in the relevant wholesale markets.

596. Nkom will base its assessment of the significance of indirect competition pressure for Telenor's ability to exercise market power in the relevant wholesale markets on the logic that underlies the SSNIP test. The assessment will therefore be based on the extent to which Telenor is able to profitably raise its wholesale prices by 5–10% on a non-transient basis.

597. Whether or not Telenor can profitably raise the price of the access products in the relevant markets will depend on three factors. The first is whether a possible price increase at the wholesale level from the vertical integrated wholesale supplier will lead to the access buyer having to increase its retail prices to maintain profitability. This will, in turn, depend on the ratio between the level of the wholesale prices and the retail price, in that the greater proportion of the retail price that the wholesale price constitutes, the more likely it is that a price increase at the wholesale level will be continued to the access buyer's prices in the retail market.

598. The impact of raised retail prices from an access buyer in isolation is that the access buyer's retail product becomes less competitive, indicating that the access buyer might lose customers in the retail market. This will, in turn, reduce the access buyers' demand for access and thus supports the view that price increases at the wholesale level are not profitable. If the wholesale cost constitutes a small proportion of the retail price, there is more reason to assume that the access buyer will be able to absorb a larger part or the entire price increase at the wholesale level, and that the access buyer therefore does not need to, or only to a limited degree needs to, transfer the price increase in its pricing of its own retail products.

599. The second factor is the extent to which there are other retail products that are substitutable with the retail products that use the wholesale products affected by the price rise as an input factor. The greater the degree of substitutability, the more alternatives the end users that are subject to the price rise from the access buyer will have. A higher degree of substitutability also suggests the existence of indirect disciplining effects on the pricing of the relevant wholesale product.

600. The third factor is the extent to which the end user's substitution possibilities will lead to the end user switching to a broadband service offered by the retail operations of the vertically

integrated wholesale provider. Here, the greater the proportion that falls to the vertically integrated provider's retail operation, the less reason there is to assume that competition pressure in the retail market is having a sufficiently disciplining effect.

601. In Market 3a the price for access to LLU is a relatively small part of the retail price. It is therefore reasonable to believe that any price increase on the wholesale product will be able to be absorbed by the access buyers, and the effect on the access buyer's pricing in the retail market will be diluted. This suggests that competition pressure from the retail market will not have a disciplining effect on the ability to raise the relevant access prices. Nkom concludes that competition pressure from the retail market will not sufficiently prevent Telenor from profitably raising its wholesale prices in Market 3a in the way described in a SSNIP test.

602. For Market 3b, the wholesale costs represent a greater proportion of the retail prices. By contrast (cf. the previous paragraph), this suggests that competition pressure from the retail market may have a greater disciplining effect in this market than in Market 3a. In the above, Nkom has argued that broadband services based on copper, HFC and fibre networks are substitutable from the end user's point of view. Since Telenor has a substantially higher market share in the retail market than the other players, it is reasonable to assume that a greater share of the actual substitution will be in the direction of Telenor's service provider. The fact that Telenor, in contrast to other vertically integrated broadband providers, offers broadband services in its own network on all three platforms is a factor that is likely to enhance substitution to services provided by Telenor's service provider. Nkom therefore assumes that competition pressure from the retail market will not sufficiently prevent Telenor from profitably raising its wholesale prices in Market 3b in the way assumed in a SSNIP test.

603. Nkom cannot see that fixed radio access has the potential to have a sufficiently disciplining effect on Telenor to counteract Telenor's ability to raise the prices of its wholesale products in Markets 3a and 3b. For example, Nkom refers to the fact that fixed radio access has very little penetration, and Nkom therefore assumes that retail user services based on this form of access will not constitute a sufficient substitute to broadband based on other platforms as mentioned above.

604. Nkom concludes on the basis of the above that competition pressure in the retail market will not have a sufficiently disciplining effect on Telenor's ability to exercise market power in the wholesale markets 3a and 3b.

3.18 Summary and conclusions

3.18.1 Market 3a

605. Telenor had a market share of 53.5% in Market 3a at the end of 2017, based on number of accesses. Telenor thus has a market share that exceeds the threshold value for

presumption of significant market power, cf. paragraph 76 of the Guidelines. By comparison, Lyse Fiber had a market share of 16.1%.

606. Nkom expects Telenor's market share to remain above 50% in the time horizon of the analysis. Furthermore, Telenor has a market share that is significantly higher than that of its competitors. Both factors indicate that it can be presumed that Telenor has significant market power.

607. In terms of market shares measured by external sales, Telenor has a stable market share of virtually 100%. This very high, stable market share is attributable to the fact that Telenor is the only provider that has an obligation to offer access to both copper-based and fibre-based access networks. There is no evidence to suggest that this position will change appreciably.

608. A conclusion regarding existence of significant market power cannot normally be based on an assessment of market shares alone. Nkom has therefore also considered a number of other criteria. There are several factors that support the conclusion that Telenor has significant market power. Telenor's relative size compared with its competitors gives the company competitive advantages that are relevant in both the retail market and the wholesale market. Furthermore, Telenor does not experience significant price pressure at the wholesale level, and there is no evidence that Telenor will be disciplined to an appreciable degree in the wholesale market given the absence of regulation. Telenor also controls a nationwide copper access network that is not easily duplicated. It would require significant investments for prospective providers to establish a fixed network that provides the basis for wholesale provision on par with Telenor's.

609. Moreover, Telenor is vertically integrated and offers broadband products in both the retail and the wholesale markets. Its position as the largest provider at both the wholesale and the retail level means Telenor has the possibility to achieve advantages from being vertically integrated. Telenor is also horizontally integrated and has a strong position in a number of adjacent markets within electronic communications, including fixed telephony, mobile telephony and TV services. Telenor's nationwide infrastructure and large customer base, at both the retail and the wholesale level, mean the company has significant economies of scale and scope. Telenor also has the opportunity to differentiate its products to a greater extent than its competitors by bundling retail products and services from multiple markets.

610. Several complaints in recent years, cf. Section 3.6, also serve to support the conclusion that Telenor has significant market power in the relevant market. The relatively high level of conflict can also be taken as evidence that there is limited competition in the wholesale market.

611. The authorities have implemented and are planning various different measures to encourage the roll-out of broadband, including a new Broadband Development Act to promote shared use of existing physical infrastructure and to improve coordination of building,

excavation and engineering projects, and amendments to the cable regulations with effect from 1 January 2018. Nkom believes that together the various regulatory measures together will have a positive effect on the roll-out of broadband in the coming regulatory period for all operators and may thus to some extent serve to reduce Telenor's market power in Market 3a.

612. Nkom has also assessed whether any potential competition and competition pressure from the retail market exist. Even though some potential competition and competition pressure from the retail market exist, Nkom has not found that there are sufficient disciplining effects from such competition to provide grounds for concluding that Telenor does not have significant market power.

613. Nkom cannot see that there is any evidence that countervailing buying power is sufficiently able to discipline Telenor in Market 3a, nor that this will change sufficiently in the period covered in this analysis.

614. On the basis of an overall assessment, Nkom concludes that Telenor has sufficient strength in Market 3a that the company can behave independently of its competitors, customers and consumers to an appreciable extent. Nkom thus concludes that Telenor has significant market power in the market for wholesale local access.

3.18.2 Market 3b

615. Telenor had a market share of 42.6% in Market 3b at the end of 2017, based on number of accesses. Telenor's market share is thus at a level where significant market power would normally be found. By comparison, Get had a market share of 16.8%.

616. In terms of market shares measured by external sales, Telenor has a stable market share of virtually 100%. This very high, stable market share is attributable to the fact that Telenor is the only provider that has an obligation to offer access to both copper-based and fibre-based access networks. There is no evidence to suggest that this position will change appreciably.

617. A conclusion regarding existence of significant market power cannot normally be based on an assessment of market shares alone. Nkom has therefore also considered a number of other criteria. There are several factors that support the conclusion that Telenor has significant market power. Telenor's relative size compared with its competitors gives the company competitive advantages that are relevant in both the retail market and the wholesale market. Furthermore, Telenor does not experience significant price pressure at the wholesale level, and there is no evidence that Telenor will be disciplined in the wholesale market given the absence of regulation. Telenor also controls a nationwide copper access network that is not easily duplicated. It would require significant investments for prospective providers to establish a wholesale provision in Market 3b that is as extensive as Telenor's existing provision.

618. Moreover, Telenor is vertically integrated and offers broadband products in both the retail and the wholesale markets. Its position as the largest provider at both the wholesale and

the retail level means Telenor has the possibility to achieve advantages from being vertically integrated. Telenor is also horizontally integrated and has a strong position in a number of adjacent markets within electronic communications, including fixed telephony, mobile telephony and TV services. Telenor's nationwide infrastructure and large customer base, at both the retail and the wholesale level, mean the company has significant economies of scale and scope. Telenor also has the opportunity to differentiate its products to a greater extent than its competitors by bundling retail products and services from multiple markets.

619. Several complaints in recent years, cf. Section 3.6 also serve to reinforce the conclusion that Telenor has significant market power in Market 3b. The relatively high level of conflict can also be taken as evidence that there is limited competition in the wholesale market.

620. The authorities have implemented and are planning various different measures to encourage the roll-out of broadband, including a new Broadband Development Act to promote shared use of existing physical infrastructure and to improve coordination of building, excavation and engineering projects, and amendments to the cable regulations with effect from 1 January 2018. Nkom believes that together the various regulatory measures together will have a positive effect on the roll-out of broadband in the coming regulatory period for all operators and may thus to some extent serve to reduce Telenor's market power in Market 3b.

621. Nkom has also assessed whether any potential competition and competition pressure from the retail market exist. Even though some potential competition and competition pressure from the retail market exist, Nkom has not found that there are sufficient disciplining effects from such competition to provide grounds for concluding that Telenor does not have significant market power.

622. Nkom cannot see that there is any evidence that countervailing buying power is sufficiently able to discipline Telenor in Market 3b, nor that this will change sufficiently in the period covered in this analysis.

623. On the basis of an overall assessment, Nkom concludes that Telenor has sufficient strength in Market 3b that the company can behave independently of its competitors, customers and consumers to an appreciable extent. Nkom thus concludes that Telenor has significant market power in the market for wholesale central access.